



LAMPIRAN

A. Proses Pembersihan Fotovoltaic





TUGAS AKHIR

B. Kotoran & Debu Fotovoltaik

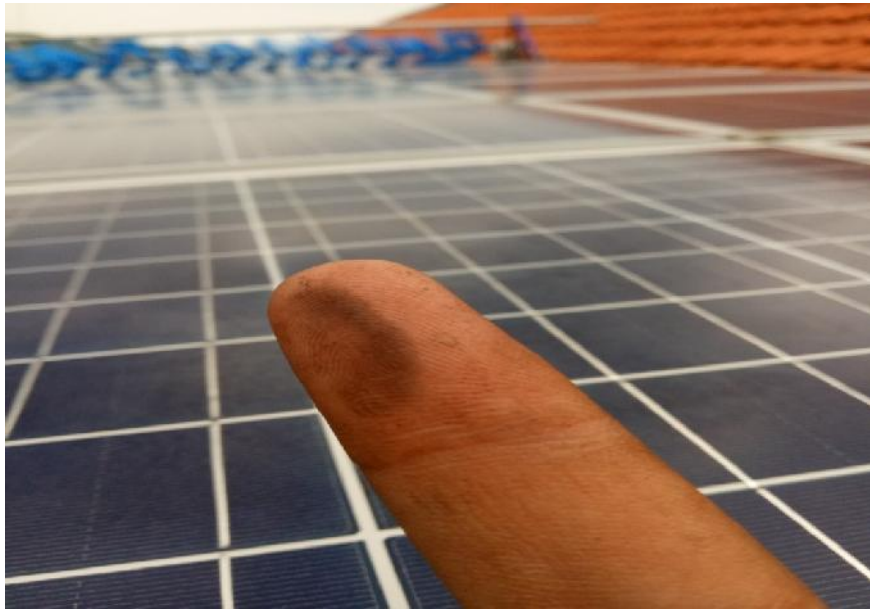

6

5

4

3

2

1

D

D

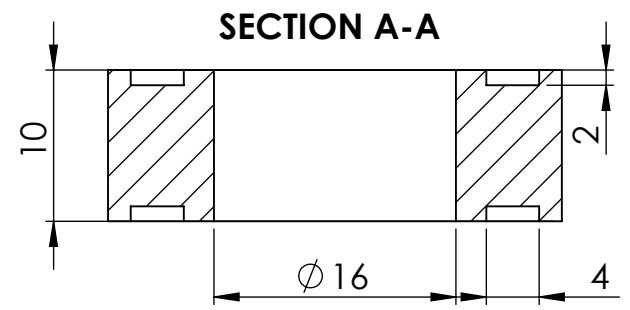

C

C

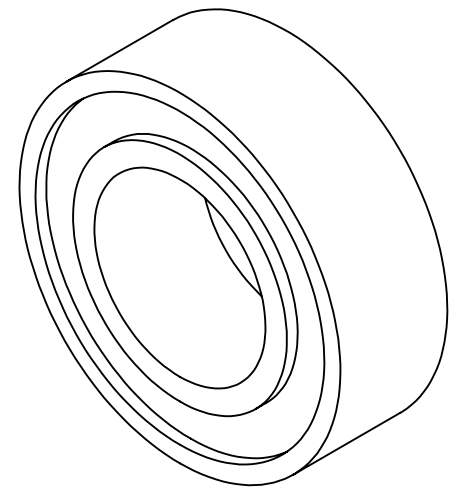
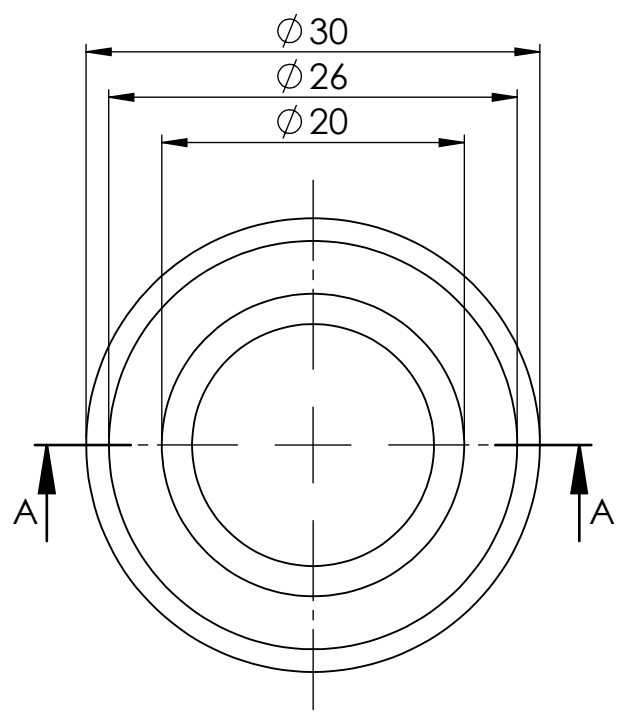

B

B

A

A

6

5

4

3

2

1

	Skala : 2 : 1	Digambar: Dimas. E	Keterangan:	
	Satuan : mm : mm	NBI :1421404571		
	Tanggal : 20/01/2021	Diperiksa : Muhyin	No: 1	A4
UNIVERSITAS 17 AGUSTUS 1945 SURABAYA		BEARING		

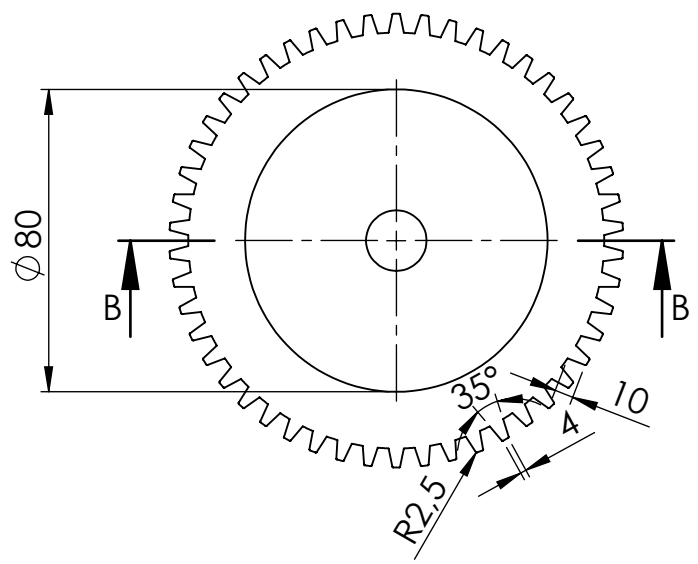

SECTION B-B

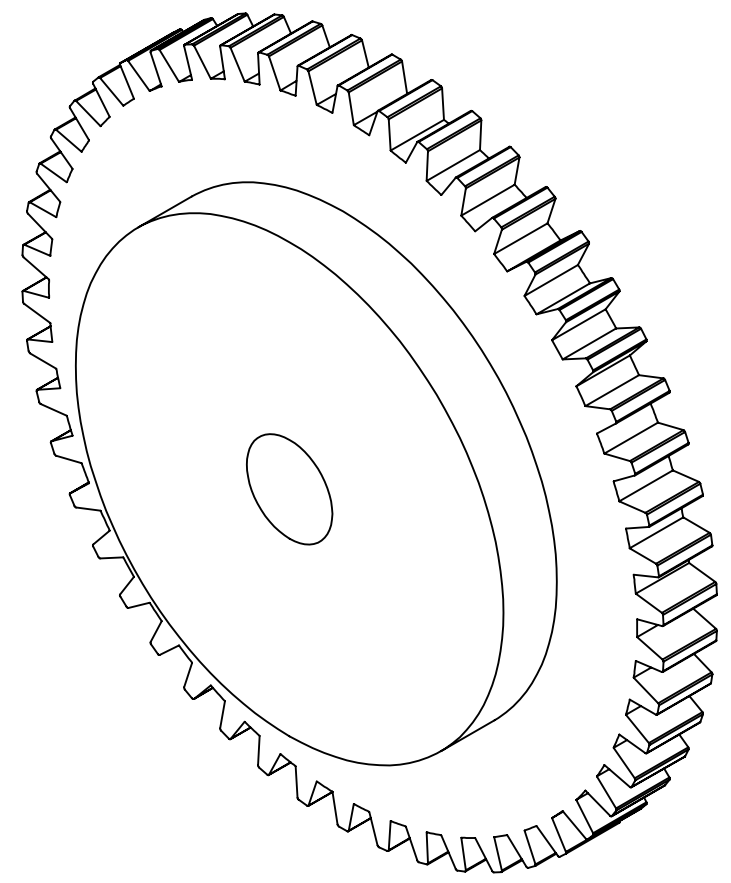
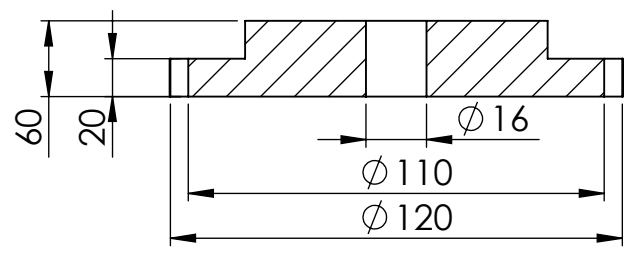

	Skala : 1 : 1	Digambar: Dimas. E	Keterangan:	
	Satuan : mm : mm	NBI :1421404571		
	Tanggal : 20/01/2021	Diperiksa : Muhyin		
UNIVERSITAS 17 AGUSTUS 1945 SURABAYA		GEAR BRUSH	No: 2	A4

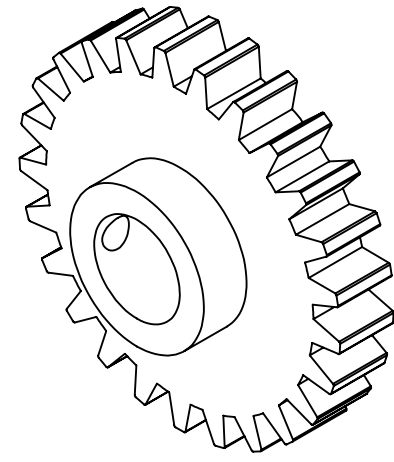
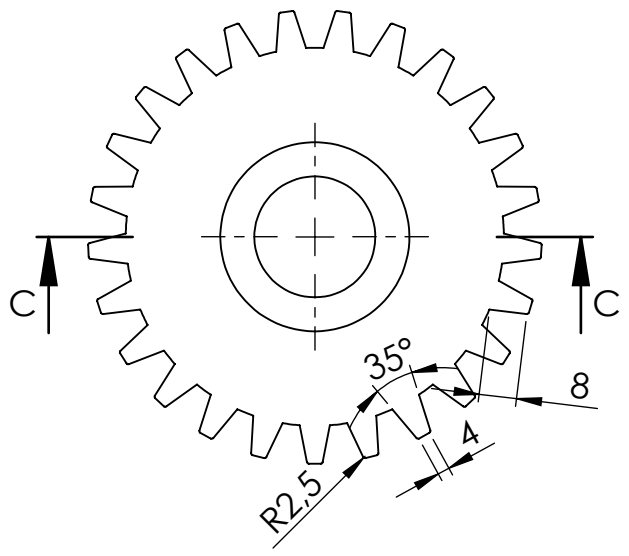

SECTION C-C

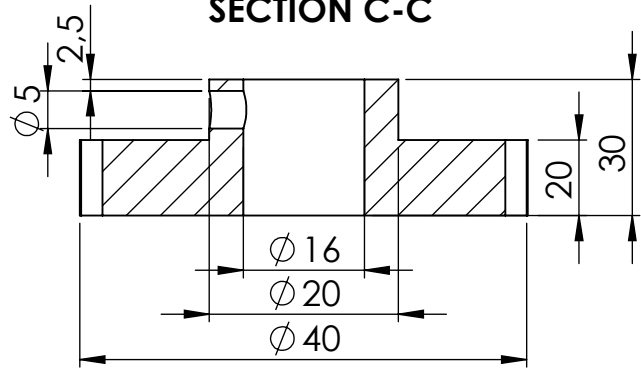

	Skala : 1 : 1	Digambar: Dimas. E	Keterangan:	
	Satuan : mm : mm	NBI :1421404571		
	Tanggal : 20/01/2021	Diperiksa : Muhyin	No: 3	A4
UNIVERSITAS 17 AGUSTUS 1945 SURABAYA		GEAR JOINT BRUSH		

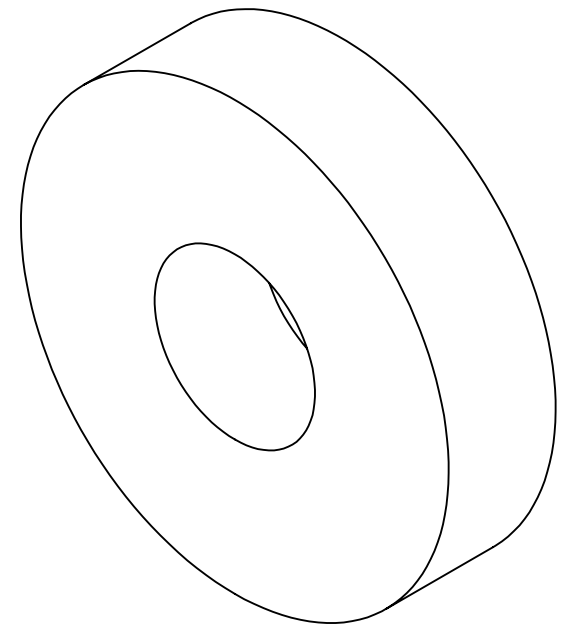
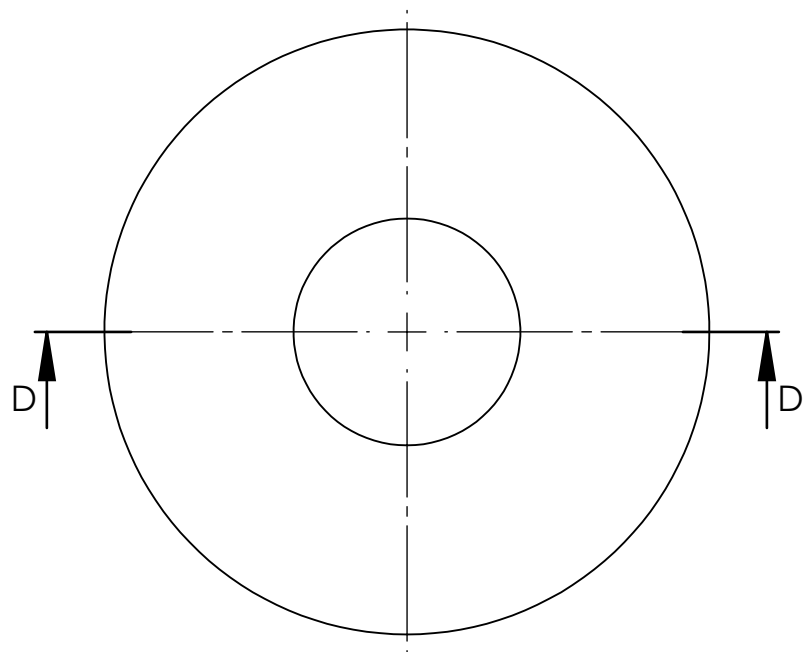

SECTION D-D

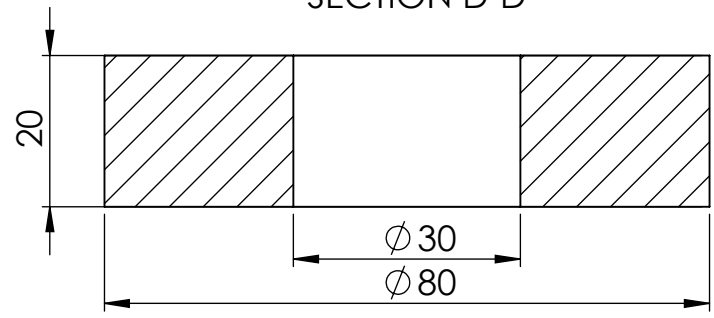

	Skala : 1 : 1	Digambar: Dimas. E	Keterangan:	
	Satuan : mm : mm	NBI :1421404571		
	Tanggal : 20/01/2021	Diperiksa : Muhyin		
UNIVERSITAS 17 AGUSTUS 1945 SURABAYA		RUBBER	No: 4	A4

6 5 4 3 2 1

D

D

C

C

B

B

A

A

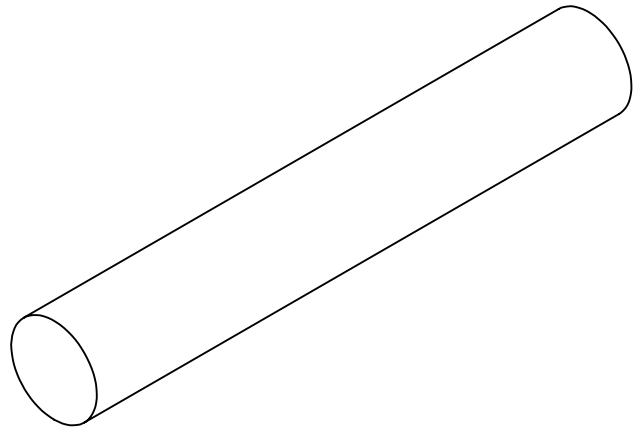
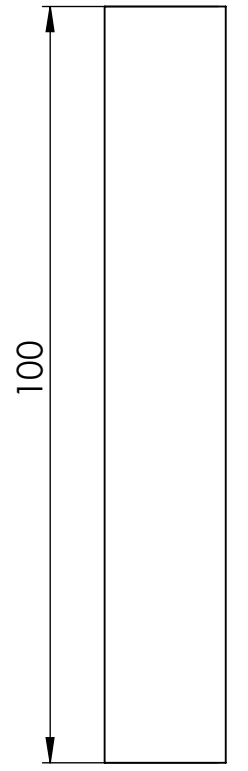

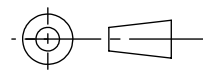
	Skala : 1 : 1	Digambar: Dimas. E	Keterangan:	
	Satuan : mm : mm	NBI :1421404571		
	Tanggal : 20/01/2021	Diperiksa : Muhyin		
UNIVERSITAS 17 AGUSTUS 1945 SURABAYA		AS Joint	No: 5	A4

6 5 4 3 2 1

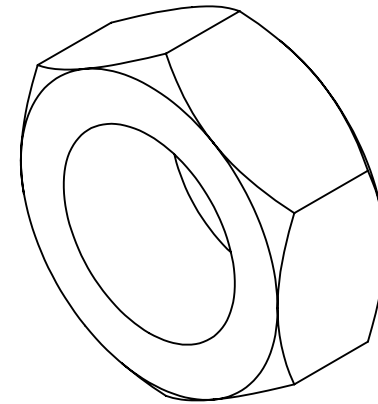
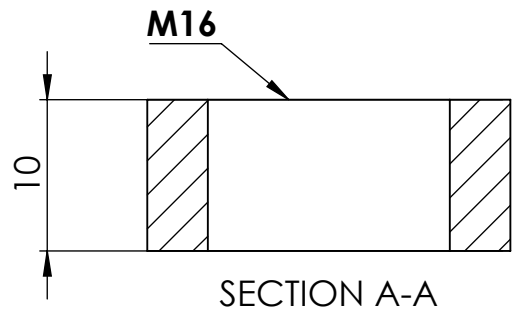
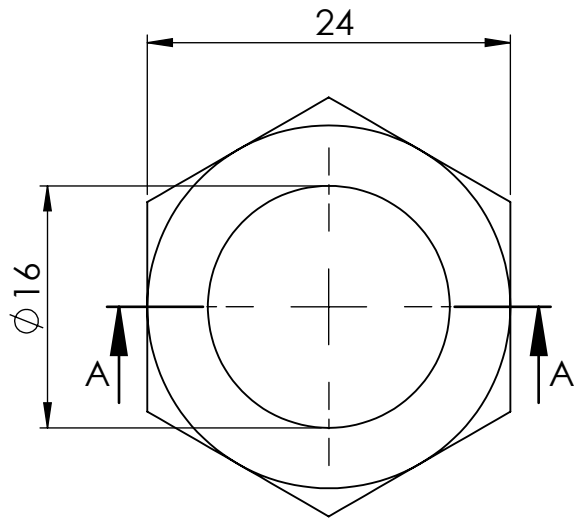

	Skala : 2 : 1	Digambar: Dimas. E	Keterangan:	
	Satuan : mm : mm	NBI :1421404571		
	Tanggal : 20/01/2021	Diperiksa : Muhyin		
UNIVERSITAS 17 AGUSTUS 1945 SURABAYA		Nut 16mm	No: 6	A4

6

5

4

3

2

1

D

C

B

A

D

C

B

A

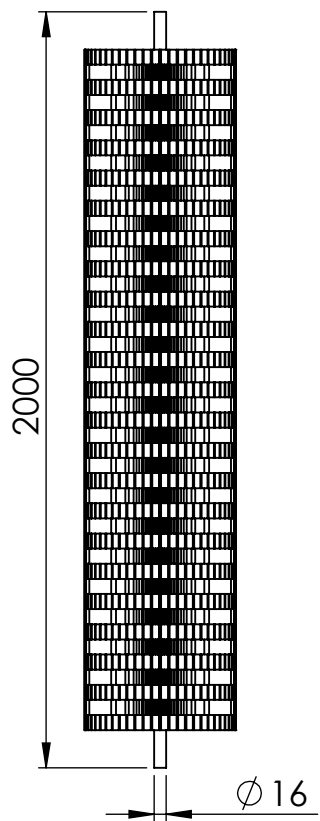

DETAIL C
SCALE 1 : 5

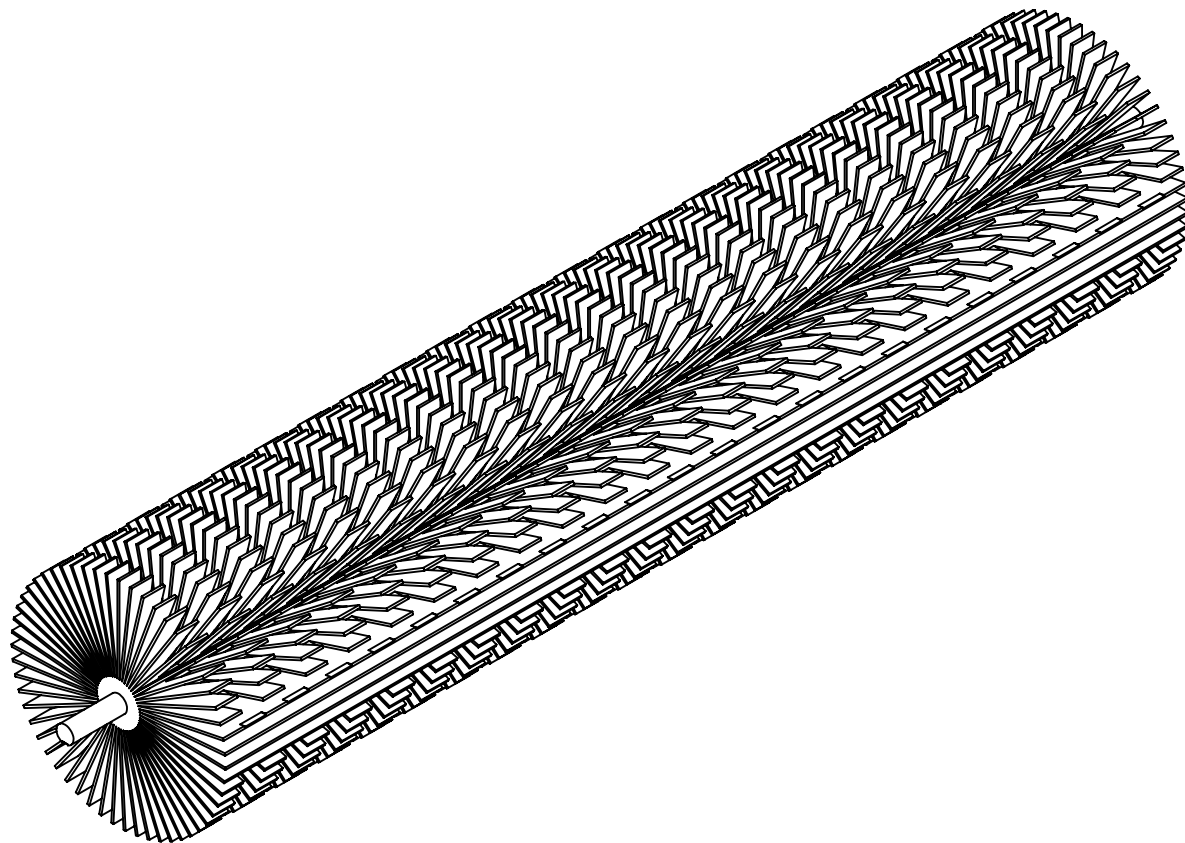
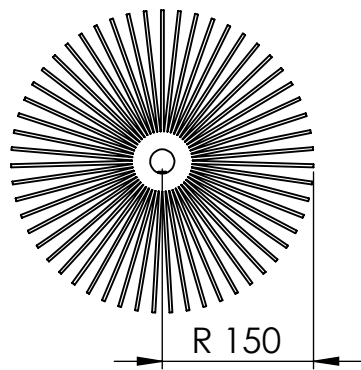
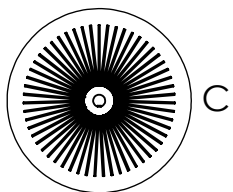

	Skala : 1 : 1	Digambar: Dimas. E	Keterangan:	
	Satuan : mm : mm	NBI :1421404571	No: 8	A4
Tanggal : 20/01/2021	Diperiksa : Muhyin	Brush		
UNIVERSITAS 17 AGUSTUS 1945 SURABAYA				

6

5

4

3

2

1

6 5 4 3 2 1

D

C

B

A

D

C

B

A

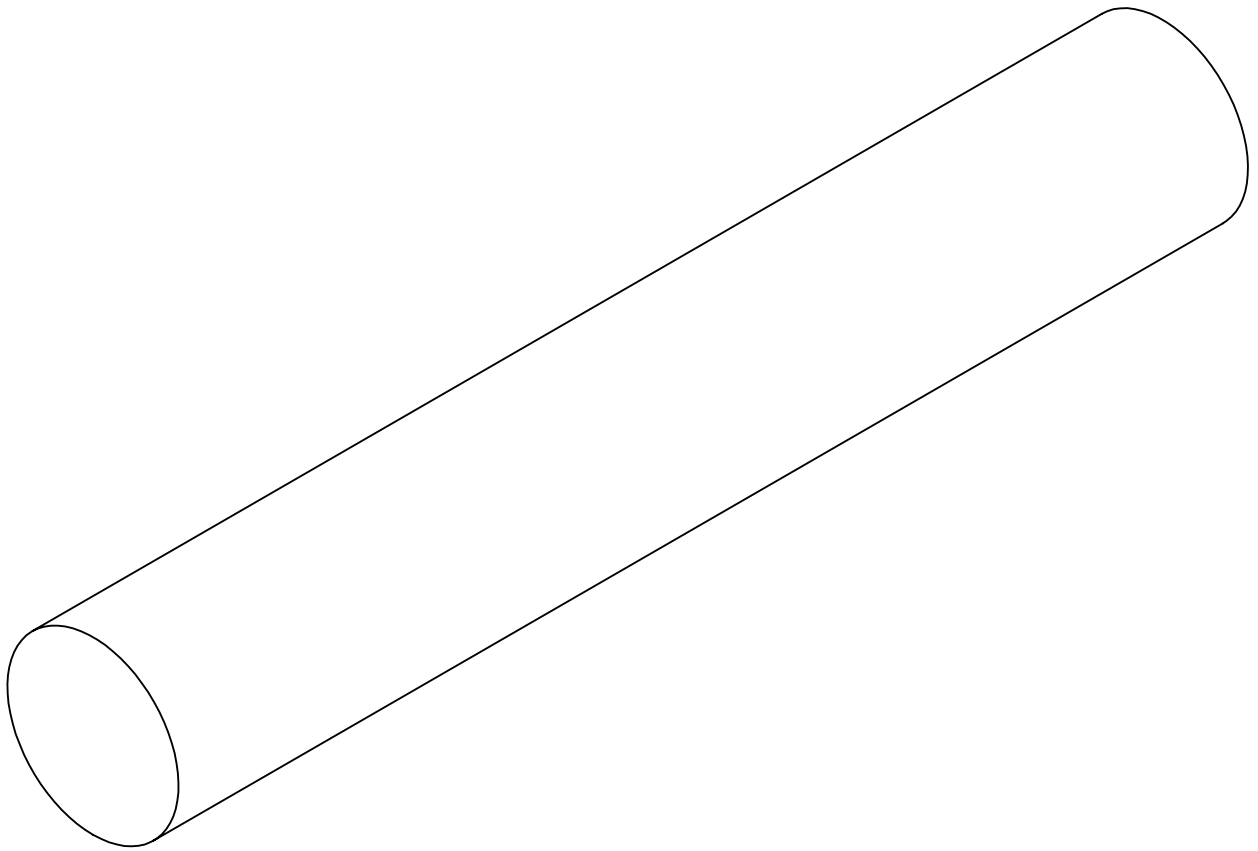
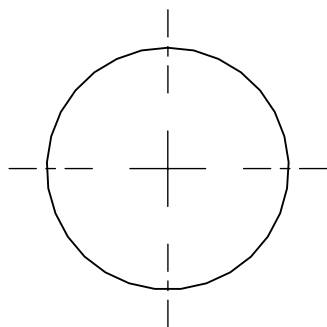
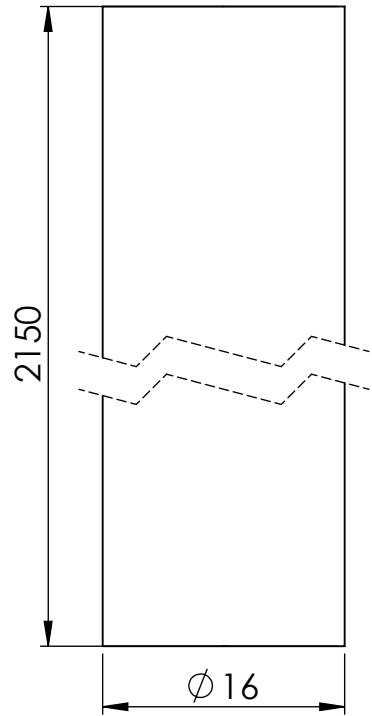

	Skala : 2 : 1	Digambar: Dimas. E	Keterangan:	
	Satuan : mm : mm	NBI :1421404571		
	Tanggal : 20/01/2021	Diperiksa : Muhyin		
UNIVERSITAS 17 AGUSTUS 1945 SURABAYA		AS Frame	No: 10	A4

6 5 4 3 2 1

6 5 4 3 2 1

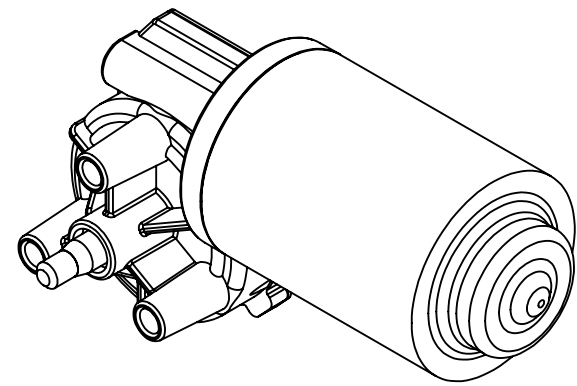
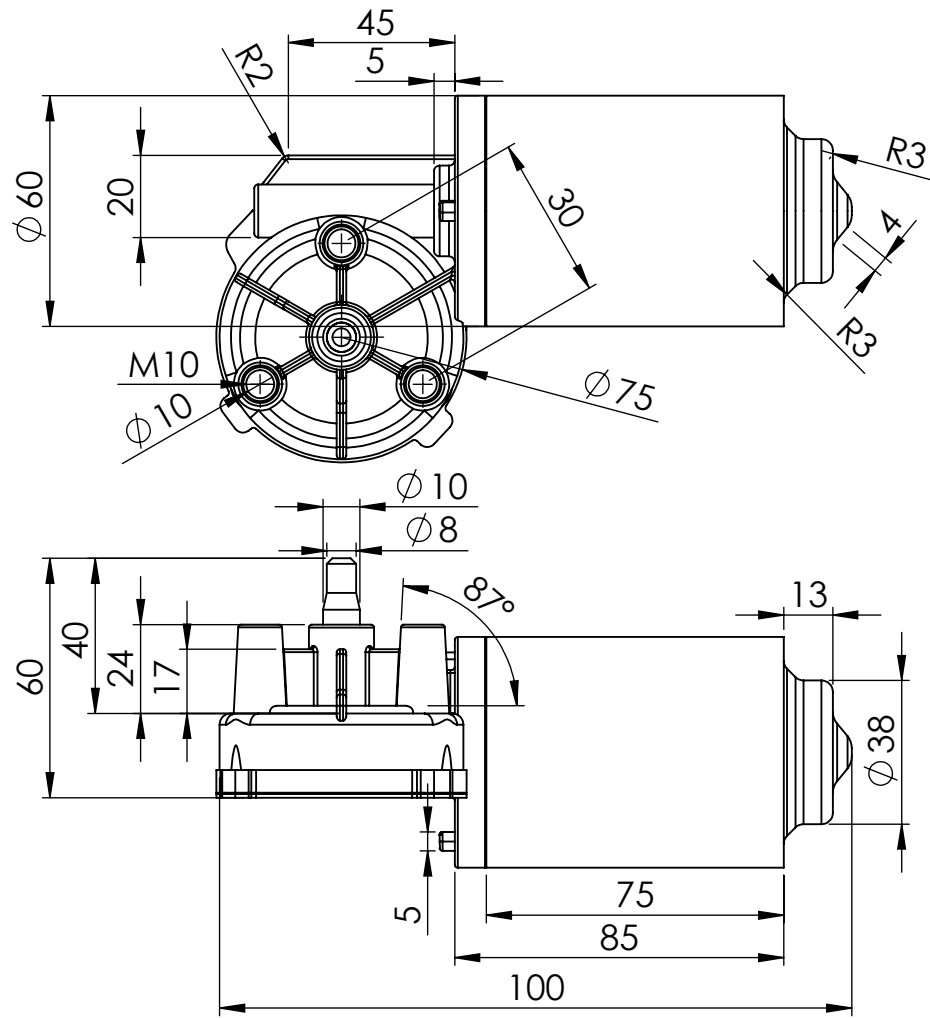

6 5 4 3 2 1

	Skala : 1 : 1	Digambar: Dimas. E	Keterangan:	
	Satuan : mm : mm	NBI :1421404571		
	Tanggal : 20/01/2021	Diperiksa : Muhyin		
UNIVERSITAS 17 AGUSTUS 1945 SURABAYA		Motor Wiper	No: 11	A4

D
C
B
A

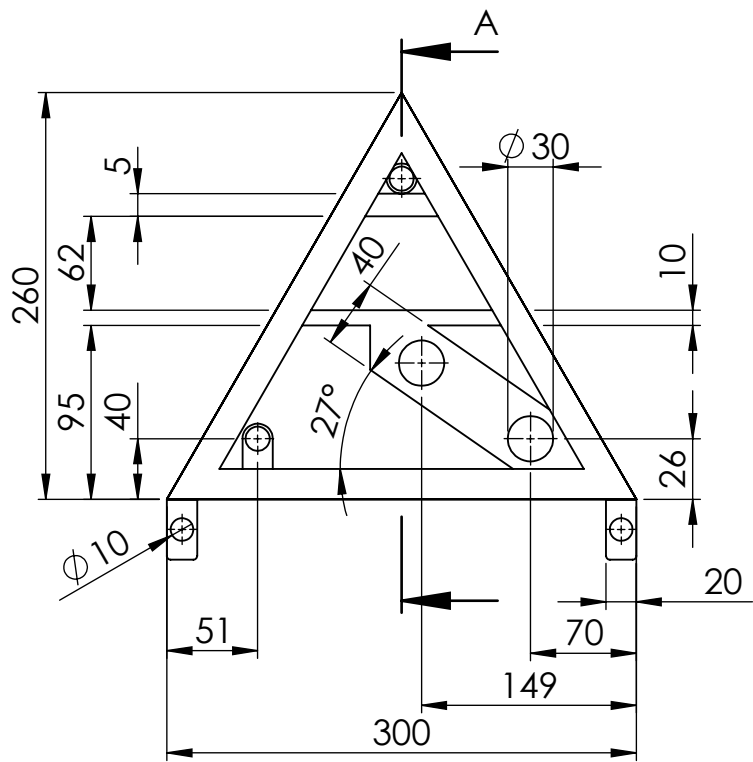

SECTION A-A

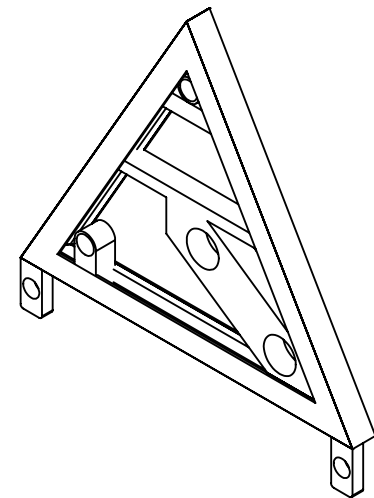
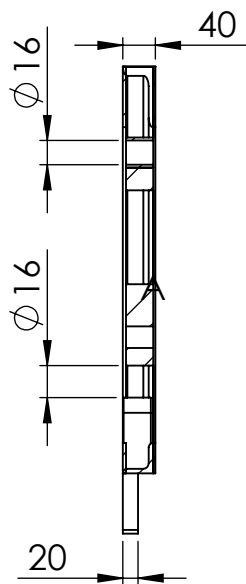

	Skala : 1 : 5	Digambar: Dimas. E	Keterangan:	
	Satuan : mm : mm	NBI :1421404571		
	Tanggal : 20/01/2021	Diperiksa : Muhyin	No:	12
UNIVERSITAS 17 AGUSTUS 1945 SURABAYA		Frame	A4	

6 5 4 3 2 1

D

C

B

A

D

C

B

A

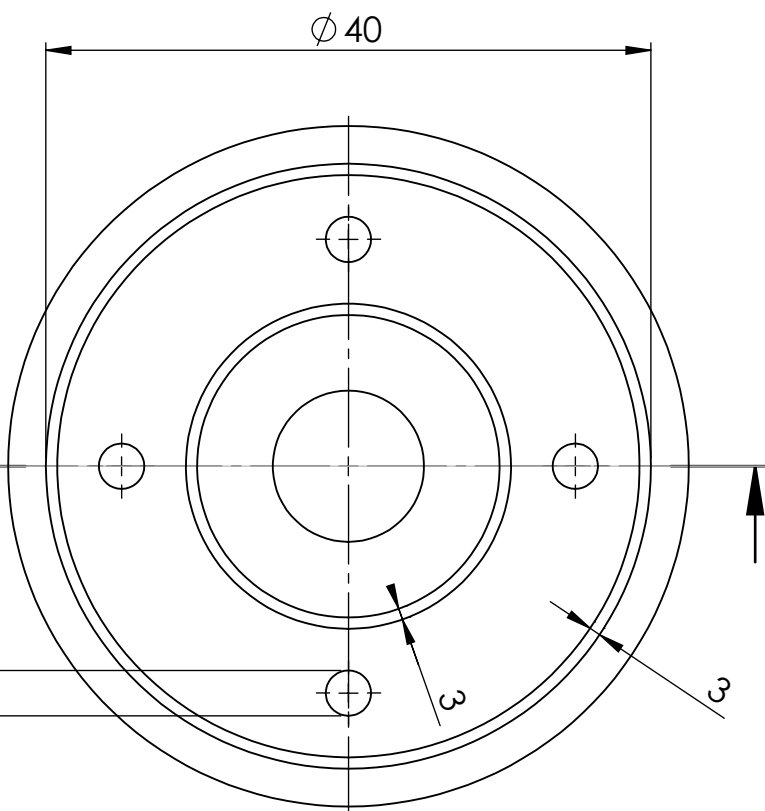

SECTION A-A
SCALE 1 : 2

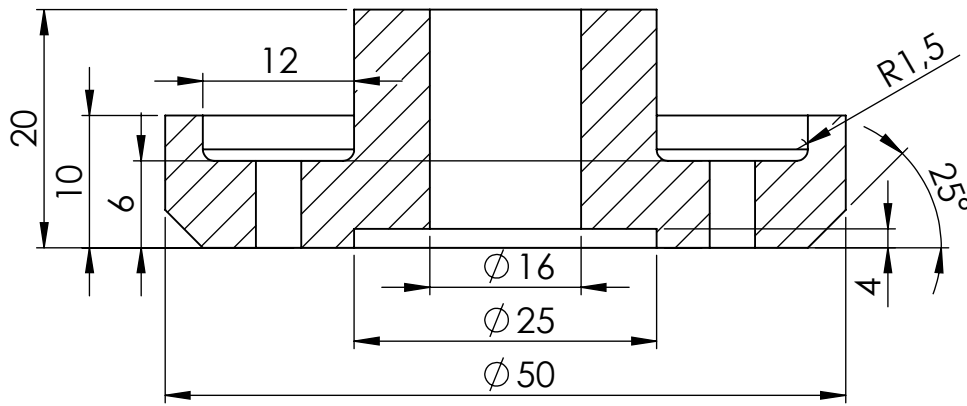
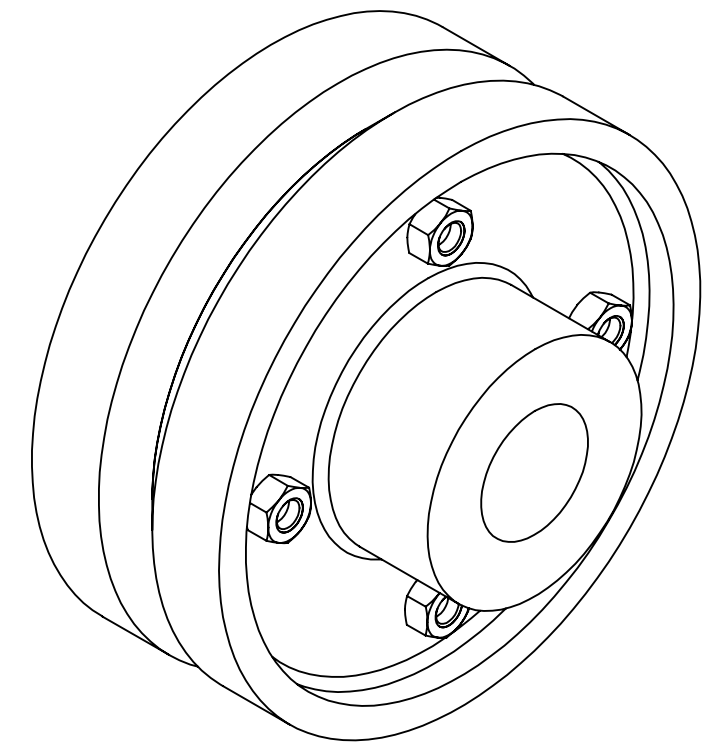

	Skala : 1 : 2	Digambar: Dimas. E	Keterangan:	
	Satuan : mm : mm	NBI :1421404571	No:	A4
	Tanggal : 20/01/2021	Diperiksa : Muhyin		
UNIVERSITAS 17 AGUSTUS 1945 SURABAYA		Coupling		

6 5 4 3 2 1

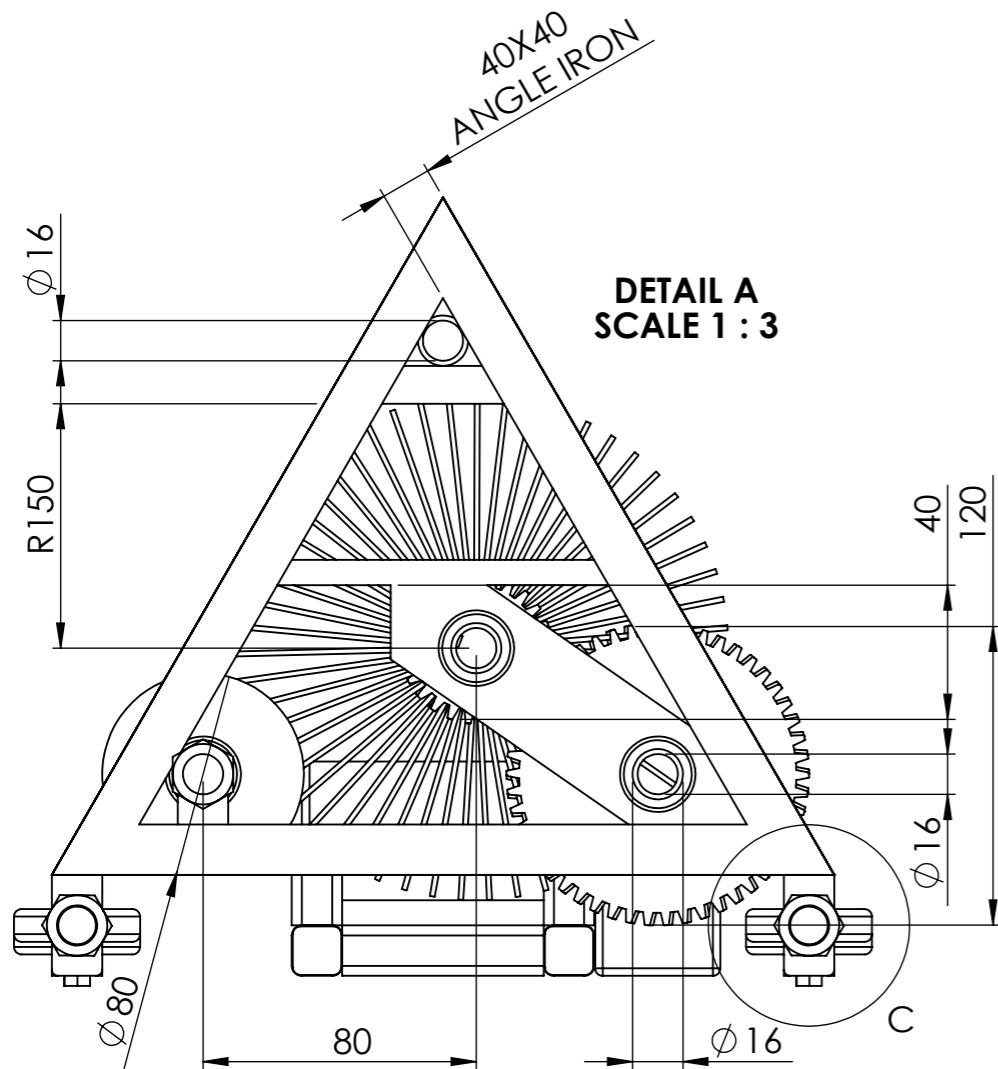

FRONT VIEW
A

ANGLE IRON
300MM

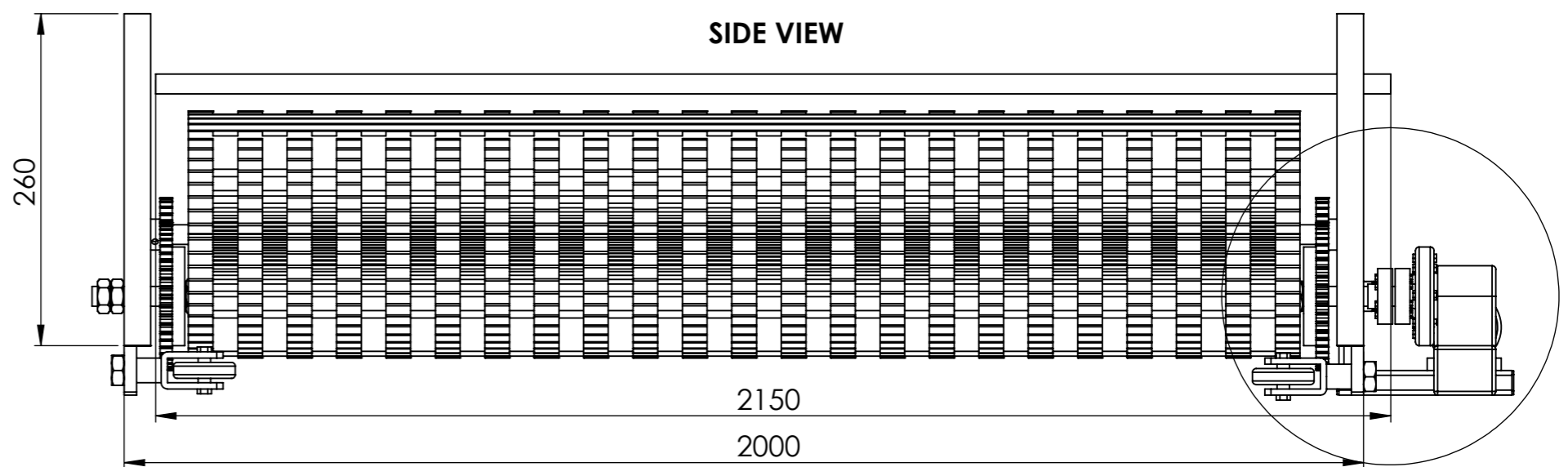
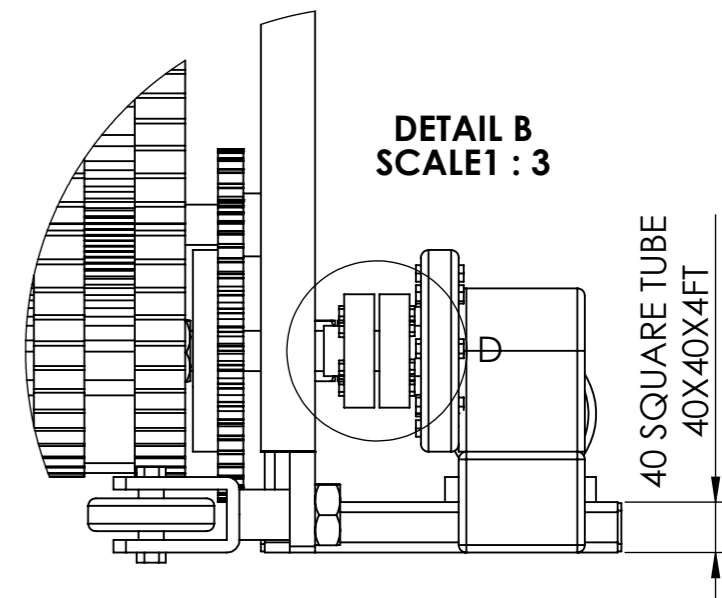
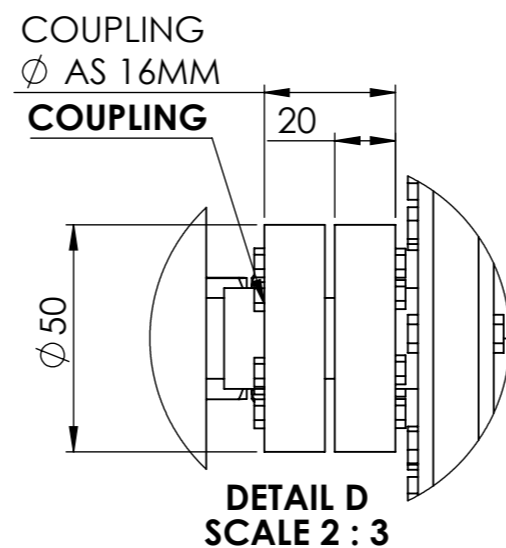
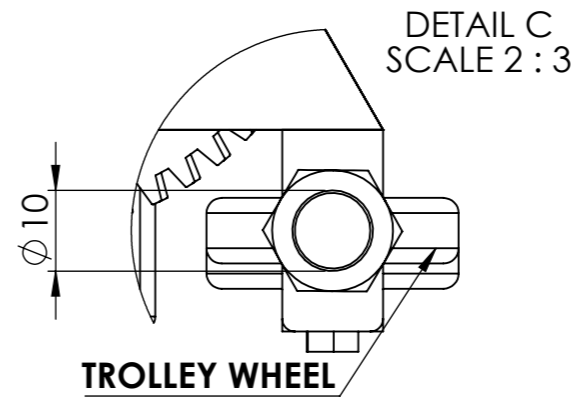
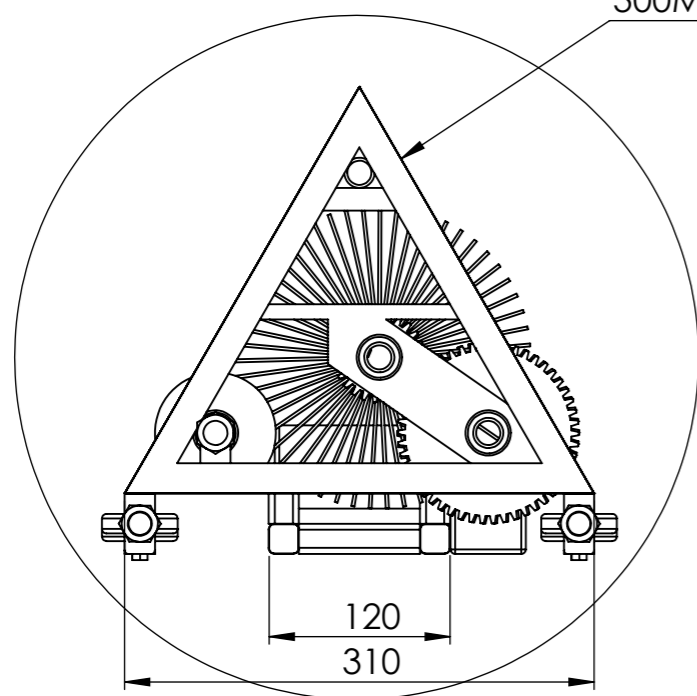

	Skala	Digambar : Dimas. E	Keterangan:
	Satuan : mm : mm	NBI :1421404571	
	Tanggal : 20/01/2021	Diperiksa : Muhyin	

UNIVERSITAS 17 AGUSTUS 1945
SURABAYA

FINAL DESIGN

No: 14

A4

ITEM NO.	PART NAME	DESCRIPTION	MATERIAL	QTY.
1	Bearing	Ø 30 x 16 mm	Chrome SAE 52100	6
2	Gear Brush	Ø 120 mm	S30C	2
3	Gear Joint Brush	Ø 40 mm	Iron ASTM 25	2
4	Rubber	Ø 80 mm	EPDM 60 Durameter	2
5	As Joint	Ø 16 mm	Ductile Iron (SN)	3
6	Nut	Ø 16 mm	ASTM A36	12
7	Lenght	2000 mm	Ductile Iron (SN)	1
8	Brush	Ø 300 mm BRUSH	-	1
9	Trolley Wheel	Standard	-	4
10	As Frame	Ø 16 x 2150 mm	Ductile Iron (SN)	1
11	Motor	Standard	-	1
12	Frame	300 X 300 X 260 mm	Angle Iron 40x40 mm	1
13	Coupling	Standard	-	2

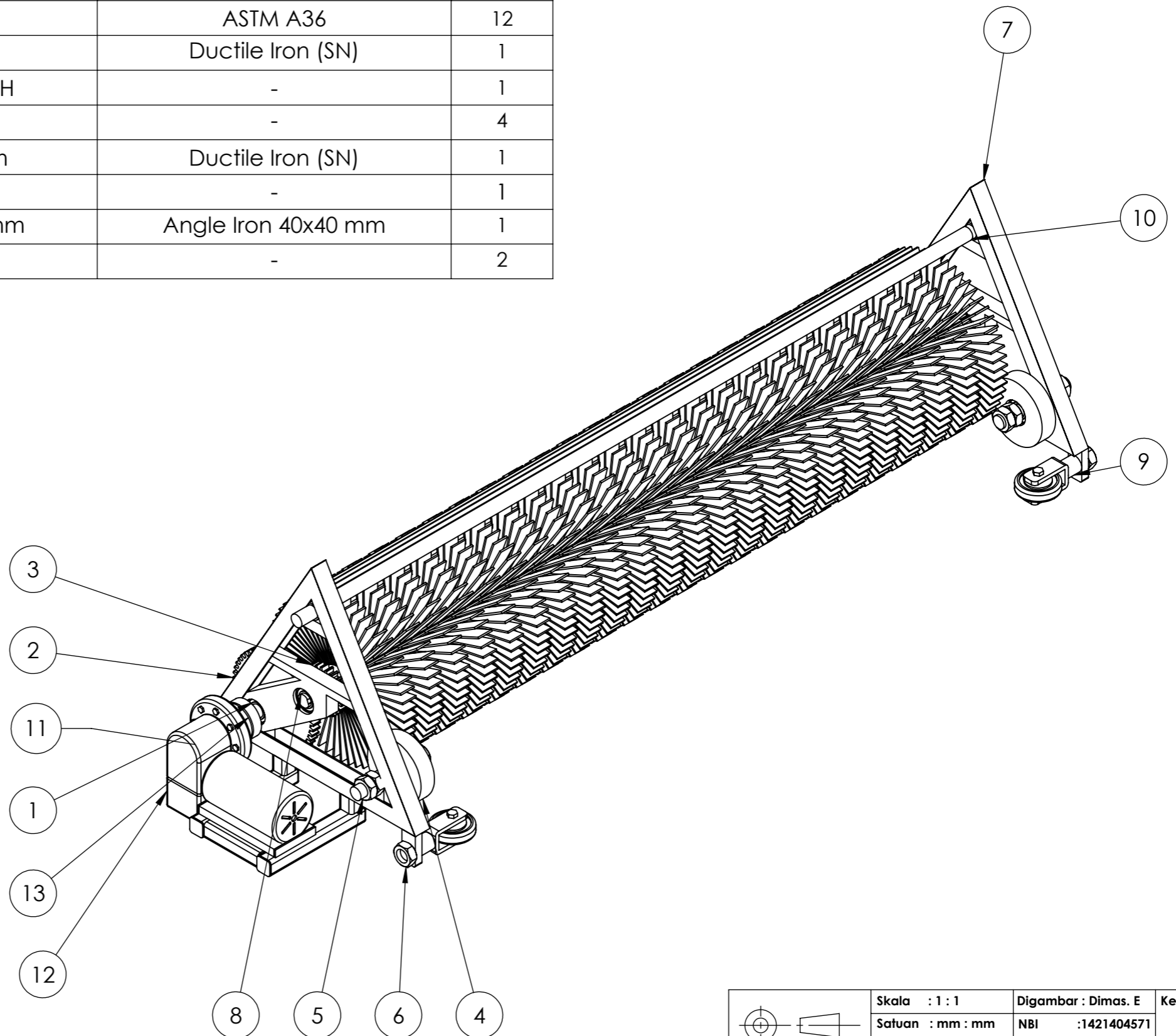

	Skala : 1 : 1	Digambar : Dimas. E	Keterangan:	
	Satuan : mm : mm	NBI :1421404571		
	Tanggal : 20/01/2021	Diperiksa : Muhyin		
UNIVERSITAS 17 AGUSTUS 1945 SURABAYA		EXPLOID DESIGN	No: 15	A4