

Lampiran

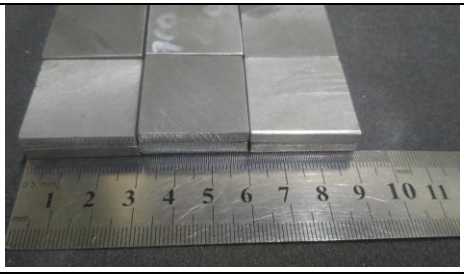

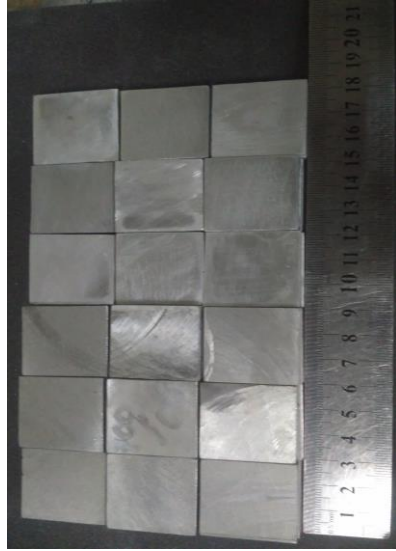



| | | | |
|-----------|------------|---------------|-------------------|
| User name | Admin | Date and time | 6/6/2018 10:17 AM |
| Inspector | SANTOSO | Checked : | SUDIYANTO |
| Approved | VY SURYADI | | |

Point (4)
x : -5.524
y : 0.011
z : 27.983

Point (3)
x : -5.456
y : 0.011
z : 13.984

Point (2)
x : -5.856
y : 0.012
z : 1.982

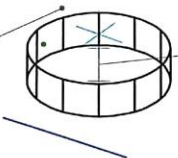

Cylinder (1)
A : 90:00:00
B : 90:00:00
C : 00:00:00
D : 18.411

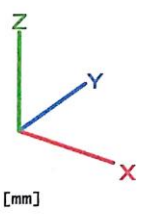

| | | | |
|-------------|------------|---------------|-------------------|
| User name | Admin | Date and time | 6/6/2018 10:24 AM |
| Inspector : | SANTOSO | Checked : | SUDIYANTO |
| Approved | VY SURYADI | | |

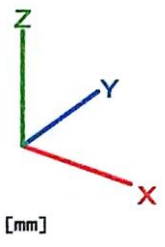
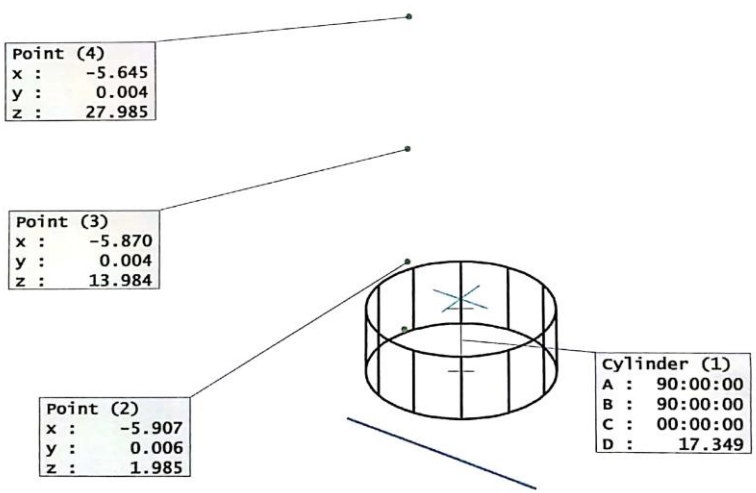

| | | | |
|-----------|------------|---------------|-------------------|
| User name | Admin | Date and time | 6/6/2018 10:31 AM |
| Inspector | SANTOSO | Checked : | SUDIYANTO |
| Approved | VY SURYADI | | |

Point (4)
x : -5.690
y : 0.011
z : 27.982

Point (3)
x : -6.043
y : 0.012
z : 13.986

Point (2)
x : -6.092
y : 0.010
z : 1.983

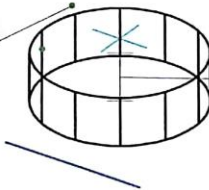

Cylinder (1)
A : 90:00:00
B : 90:00:00
C : 00:00:00
D : 18.895

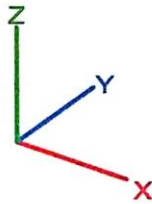

[mm]

ATMI-IGI
6/6-18

BENDA B4 [mm]

Graphics of elements

| | | | |
|-----------|------------|---------------|-------------------|
| User name | Admin | Date and time | 6/6/2018 11:43 AM |
| Inspector | SANTOSO | Checked | SUDIYANTO |
| Approved | VY SURYADI | | |

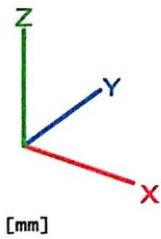
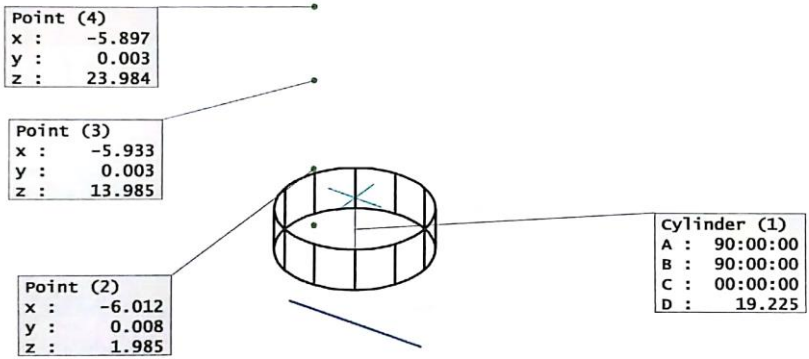

BENDA B5 [mm]

Graphics of elements

| | | | |
|-----------|------------|---------------|-------------------|
| User name | Admin | Date and time | 6/6/2018 11:51 AM |
| Inspector | SANTOSO | Checked | SUDIYANTO |
| Approved | VY SURYADI | | |

Point (4)
x : -5.891
y : 0.010
z : 23.990

Point (3)
x : -6.130
y : 0.011
z : 13.987

Point (2)
x : -6.066
y : 0.012
z : 1.990

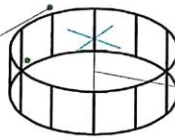

Cylinder (1)
A : 90:00:00
B : 90:00:00
C : 00:00:00
D : 18.722

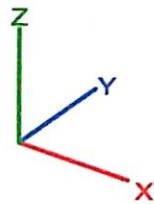

[mm]

ATMI-IGI
6/5/18

At [mm]

Graphics of elements

| | | | |
|-------------|------------|---------------|-------------------|
| User name | Admin | Date and time | 6/28/2018 1:59 PM |
| Inspector : | SANTOSO | Checked | SUDIYANTO |
| Approved : | VY SURYADI | | |

Point (4)
x : -4.497
z : 27.993

Point (3)
x : -5.646
z : 13.995

Point (2)
x : -5.953
z : 1.995

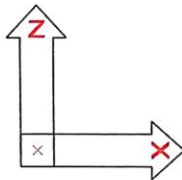

[mm]

PT. ATMI IGI CENTER
QC PASSED
Sign: 
Date: 28 / 6 / 2018

 28/6-18

| | | | |
|-------------|------------|---------------|-------------------|
| User name | Admin | Date and time | 6/28/2018 2:04 PM |
| Inspector : | SANTOSO | Checked | SUDIYANTO |
| Approved | VY SURYADI | | |

Point (4)
x : -5.983
z : 27.994

Point (3)
x : -6.258
z : 13.995

Point (2)
x : -6.161
z : 1.994

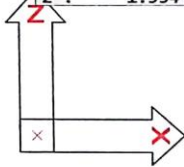

[mm]

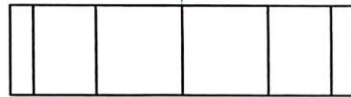

[Handwritten signature] 28/6-18

| | | | |
|-----------|------------|---------------|-------------------|
| User name | Admin | Date and time | 6/28/2018 2:09 PM |
| Inspector | SANTOSO | Checked | SUDIYANTO |
| Approved | VY SURYADI | | |

Point (4)
 x : -5.685
 z : 27.990

Point (3)
 x : -5.903
 z : 13.996

Point (2)
 x : -5.910
 z : 1.990

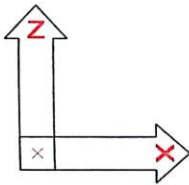

[mm]

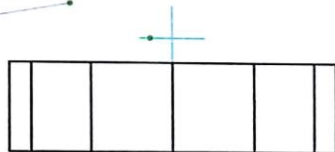

Paul 28/6-18

| | | | |
|-------------|------------|---------------|-------------------|
| User name | Admin | Date and time | 6/28/2018 2:14 PM |
| Inspector : | SANTOSO | Checked | SUDIYANTO |
| Approved | VY SURYADI | | |

Point (4)
x : -6.042
z : 27.994

Point (3)
x : -6.083
z : 13.994

Point (2)
x : -6.144
z : 1.995

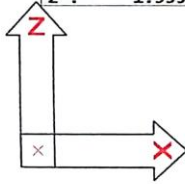

[Handwritten signature] 28/6-18

[mm]

AS [mm]

| | | | |
|-----------|------------|---------------|-------------------|
| User name | Admin | Date and time | 6/28/2018 2:19 PM |
| Inspector | SANTOSO | Checked | SUDIYANTO |
| Approved | VY SURYADI | | |

Point (4)
 x : -5.413
 z : 23.995

Point (3)
 x : -5.900
 z : 13.991

Point (2)
 x : -5.874
 z : 1.998

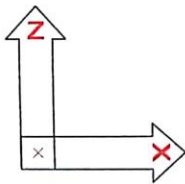

[mm]

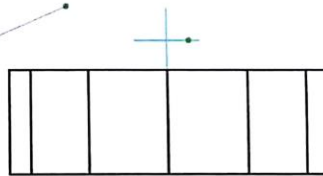

[Handwritten signature] 28/6/18

Sebelum

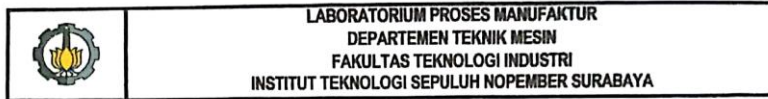

DATA PENGUKURAN KEKASARAN PERMUKAAN BENDA KERJA

Nama Mahasiswa : Akbar Maulana
NIM : 1421404551
Bidang Sudi/Jurusan : Teknik Mesin
Judul TA : Kaji Eksperimen Pengaruh Variasi Volume Cairan Dan Temperatur Perkakas Pada Metoda Squeeze Casting Terhadap Perubahan Bentuk Dimensi Dan Kekasaran Permukaan Bahan Mur Dan Baut Dari Komposit Aluminium Paduan-Abu Dasar Batubara.

Dosen Pembimbing : Harjo Seputro, ST, MT

Benda kerja : Aluminium paduan, dimensi : 30 x 30 x 03 mm
Jenis Pahat : Face mill HSS Ø 42 mm

Setting Pemesinan : Putaran Spindel Mesin (n) = 300 r/min
Feeding (f) = 400 mm/min
Kedalaman pemakanan (a) = 0,5 mm

| Volume cairan (ml) | Temperatur perkakas (°C) | Ra (µm) | | | Nilai rata-rata (µm) |
|--------------------|--------------------------|--------------|--------------|--------------|----------------------|
| | | Pengukuran 1 | Pengukuran 2 | Pengukuran 3 | |
| 450ml | 300 | 0,23 | 0,24 | 0,22 | 0,23 |
| | 400 | 0,29 | 0,31 | 0,44 | 0,34 |
| | 500 | 0,53 | 0,51 | 0,49 | 0,51 |
| 500ml | 300 | 0,56 | 0,54 | 0,58 | 0,56 |
| | 400 | 0,61 | 0,61 | 0,64 | 0,62 |
| | 500 | 0,67 | 0,66 | 0,67 | 0,66 |
| 550ml | 300 | 0,68 | 0,80 | 0,75 | 0,74 |
| | 400 | 0,94 | 1,06 | 0,91 | 0,97 |
| | 500 | 1,09 | 1,88 | 1,21 | 1,34 |

Surabaya, 06 Juli 2018

Petugas Laboratorium

PLP Ahli Madya

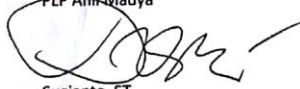
Sugianto, ST

Sebuah



LABORATORIUM PROSES MANUFAKTUR
DEPARTEMEN TEKNIK MESIN
FAKULTAS TEKNOLOGI INDUSTRI
INSTITUT TEKNOLOGI SEPULUH NOPEMBER SURABAYA

DATA PENGUKURAN KEKASARAN PERMUKAAN BENDA KERJA

Nama Mahasiswa : Akbar Maulana
NIM : 1421404551
Bidang Sudi/Jurusan : Teknik Mesin
Judul TA : Kaji Eksperimen Pengaruh Variasi Volume Cairan Dan Temperatur Perkakas Pada Metoda Squeeze Casting Terhadap Perubahan Bentuk Dimensi Dan Kekasaran Permukaan Bahan Mur Dan Baut Dari Komposit Alumunium Paduan-Abu Dasar Batubara.

Dosen Pembimbing : Harjo Seputro, ST, MT

Benda kerja : Alumunium paduan, dimensi : 30 x 30 x 03 mm
Jenis Pahat : Face mill HSS Ø 42 mm

Setting Pemesinan : Putaran Spindel Mesin (n) = 300 r/min
Feeding (f) = 400 mm/min
Kedalaman pemakanan (a) = 0,5 mm

| Volume cairan (ml) | Temperatur perkakas (°C) | Ra (µm) | | | Nilai rata-rata (µm) |
|--------------------|--------------------------|--------------|--------------|--------------|----------------------|
| | | Pengukuran 1 | Pengukuran 2 | Pengukuran 3 | |
| 450ml | 300 | 1,39 | 1,19 | 1,06 | 1,19 |
| | 400 | 1,49 | 1,28 | 1,05 | 1,27 |
| | 500 | 1,44 | 1,17 | 1,26 | 1,29 |
| 500ml | 300 | 1,19 | 1,44 | 1,49 | 1,37 |
| | 400 | 1,50 | 1,76 | 1,05 | 1,43 |
| | 500 | 1,41 | 1,59 | 1,34 | 1,45 |
| 550ml | 300 | 1,80 | 1,91 | 1,36 | 1,69 |
| | 400 | 1,96 | 1,76 | 1,97 | 1,89 |
| | 500 | 1,81 | 1,86 | 2,04 | 1,90 |

Surabaya, 06 Juli 2018
Petugas Laboratorium
PTP Ahli Madya

Sugianto, ST