

LAMPIRAN





**LABORATORIUM MATERIAL TEKNIK MESIN
UNIVERSITAS SEBELAS MARET**

SURAT KETERANGAN

Laboratorium Material Teknik Mesin UNS menerangkan bahwa :

Nama : Ahmad Fahmi Lubia Ashari

NIM : 1421504691

Institusi : Universitas 17 Agustus 1945 (UNTAG) Surabaya
Jln. Semolowaru No 45 Surabaya

Telah melakukan penelitian pengujian Tarik dengan judul “Rancang bangun mesin uji tarik uji bending dan uji tekan untuk pengujian bahan komposit dan polimer” pada tanggal 31 Oktober 2019 di laboratorium Material Teknik Mesin UNS.

Demikian surat ini dibuat untuk dapat dipergunakan sebagaimana mestinya.

Surakarta, 31 Oktober 2019

Kepala Laboratorium
Material Teknik Mesin UNS



Dr. Ir. Wijang Wisnu Raharjo. MT.
NIP 196810041999031002



KEMENTERIAN RISET TEKNOLOGI DAN PENDIDIKAN TINGGI
UNIVERSITAS SEBELAS MARET
FAKULTAS TEKNIK PROGRAM STUDI TEKNIK MESIN
LABORATORIUM MATERIAL
Jln. Ir. Sutami 36a Kentingan Surakarta 57136 telp (0271) 632163
Website : www.mesin.uns.ac.id

TABEL HASIL UJI TEKAN

No	Nama Spesimen	Diameter (mm)	Tinggi (mm)	Luas (mm ²)	Gaya Tekan Max (kN)
1	Polyamida/Nilon	12.7	25.4	506.45	4.71
2	Polyamida/Nilon	12.7	25.4	506.45	4.34
3	Polyamida/Nilon	12.7	25.4	506.45	3.35
4	Polyamida/Nilon	12.7	25.4	506.45	2.26
5	Polyamida/Nilon	12.7	25.4	506.45	3

Compression Test(ASTM E910)Testing Report

Name	diameter of specimen(d)	maximum force(Fo)
ID	mm	kN
NO.1	12.70	4.71

Displacement	Force
0.0	0.0
0.1	1.1
0.2	1.8
0.3	2.5
0.4	3.0
0.5	3.5
0.6	3.8
0.7	4.1
0.8	4.4
0.9	4.6
1.0	4.7
1.1	4.7
1.2	4.6
1.3	4.5
1.4	4.4
1.5	4.3
1.6	4.2
1.7	4.1
1.8	4.0
1.9	3.9
2.0	3.8
2.1	3.7
2.2	3.6
2.3	3.5
2.4	3.4
2.5	3.3
2.6	3.2
2.7	3.1
2.8	3.0
2.9	2.9
3.0	2.8
3.1	2.7
3.2	2.6
3.3	2.5
3.4	2.4
3.5	2.3
3.6	2.2
3.7	2.1
3.8	2.0
3.9	1.9
4.0	1.8
4.1	1.7
4.2	1.6
4.3	1.5
4.4	1.4
4.5	1.3
4.6	1.2
4.7	1.1
4.8	1.0
4.9	0.9
5.0	0.8
5.1	0.7
5.2	0.6
5.3	0.5
5.4	0.4
5.5	0.3
5.6	0.2
5.7	0.1
5.8	0.0
5.9	0.0
6.0	0.0
6.1	0.0
6.2	0.0
6.3	0.0
6.4	0.0
6.5	0.0
6.6	0.0
6.7	0.0
6.8	0.0
6.9	0.0
7.0	0.0
7.1	0.0
7.2	0.0
7.3	0.0
7.4	0.0
7.5	0.0
7.6	0.0
7.7	0.0
7.8	0.0
7.9	0.0
8.0	0.0
8.1	0.0
8.2	0.0
8.3	0.0
8.4	0.0
8.5	0.0
8.6	0.0
8.7	0.0
8.8	0.0
8.9	0.0
9.0	0.0
9.1	0.0
9.2	0.0
9.3	0.0
9.4	0.0
9.5	0.0
9.6	0.0
9.7	0.0
9.8	0.0
9.9	0.0
10.0	0.0
10.1	0.0
10.2	0.0
10.3	0.0
10.4	0.0
10.5	0.0
10.6	0.0
10.7	0.0
10.8	0.0
10.9	0.0
11.0	0.0
11.1	0.0
11.2	0.0
11.3	0.0
11.4	0.0
11.5	0.0
11.6	0.0
11.7	0.0
11.8	0.0
11.9	0.0
12.0	0.0
12.1	0.0
12.2	0.0
12.3	0.0
12.4	0.0
12.5	0.0
12.6	0.0
12.7	0.0
12.8	0.0
12.9	0.0
13.0	0.0
13.1	0.0
13.2	0.0
13.3	0.0
13.4	0.0
13.5	0.0
13.6	0.0
13.7	0.0
13.8	0.0
13.9	0.0
14.0	0.0
14.1	0.0
14.2	0.0
14.3	0.0
14.4	0.0
14.5	0.0
14.6	0.0
14.7	0.0
14.8	0.0
14.9	0.0
15.0	0.0

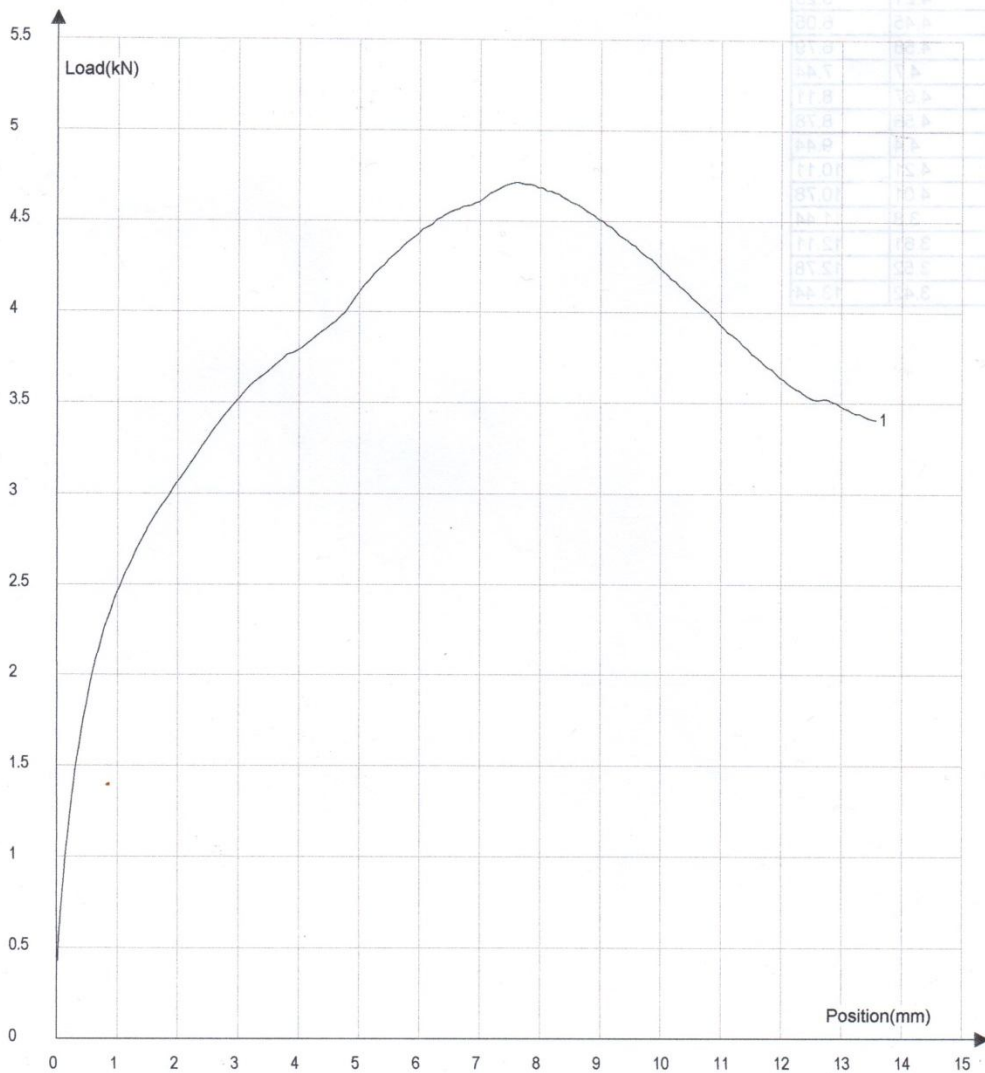

Tester:

Audit:

(Testing Report)

Gaya N	Defleksi mm
0.43	0.01
1.17	0.19
1.9	0.52
2.45	0.99
2.82	1.52
3.12	2.11
3.46	2.85
3.72	3.65
3.91	4.45
4.21	5.25
4.45	6.05
4.58	6.79
4.7	7.44
4.67	8.11
4.56	8.78
4.4	9.44
4.21	10.11
4.01	10.78
3.8	11.44
3.61	12.11
3.52	12.78
3.42	13.44

Compression Test(ASTM E910)Testing Report

Name	diameter of specimen(d)	maximum force(Fo)
ID	mm	kN
NO.1	12.70	16.85

Load(kN)	Displacement(mm)
10.0	34.0
15.0	49.0
20.0	78.7
25.0	107.5
30.0	136.3
35.0	165.1
40.0	193.9
45.0	222.7
50.0	251.5
55.0	280.3
60.0	309.1
65.0	337.9
70.0	366.7
75.0	395.5
80.0	424.3
85.0	453.1
90.0	481.9
95.0	510.7
100.0	539.5
105.0	568.3
110.0	597.1
115.0	625.9
120.0	654.7
125.0	683.5
130.0	712.3
135.0	741.1
140.0	769.9
145.0	798.7
150.0	827.5
155.0	856.3
160.0	885.1
165.0	913.9
170.0	942.7
175.0	971.5
180.0	1000.3
185.0	1029.1
190.0	1057.9
195.0	1086.7
200.0	1115.5
205.0	1144.3
210.0	1173.1
215.0	1201.9
220.0	1230.7
225.0	1259.5
230.0	1288.3
235.0	1317.1
240.0	1345.9
245.0	1374.7
250.0	1403.5
255.0	1432.3
260.0	1461.1
265.0	1489.9
270.0	1518.7
275.0	1547.5
280.0	1576.3
285.0	1605.1
290.0	1633.9
295.0	1662.7
300.0	1691.5
305.0	1720.3
310.0	1749.1
315.0	1777.9
320.0	1806.7
325.0	1835.5
330.0	1864.3
335.0	1893.1
340.0	1921.9
345.0	1950.7
350.0	1979.5
355.0	2008.3
360.0	2037.1
365.0	2065.9
370.0	2094.7
375.0	2123.5
380.0	2152.3
385.0	2181.1
390.0	2209.9
395.0	2238.7
400.0	2267.5
405.0	2296.3
410.0	2325.1
415.0	2353.9
420.0	2382.7
425.0	2411.5
430.0	2440.3
435.0	2469.1
440.0	2497.9
445.0	2526.7
450.0	2555.5
455.0	2584.3
460.0	2613.1
465.0	2641.9
470.0	2670.7
475.0	2699.5
480.0	2728.3
485.0	2757.1
490.0	2785.9
495.0	2814.7
500.0	2843.5
505.0	2872.3
510.0	2901.1
515.0	2929.9
520.0	2958.7
525.0	2987.5
530.0	3016.3
535.0	3045.1
540.0	3073.9
545.0	3102.7
550.0	3131.5
555.0	3160.3
560.0	3189.1
565.0	3217.9
570.0	3246.7
575.0	3275.5
580.0	3304.3
585.0	3333.1
590.0	3361.9
595.0	3390.7
600.0	3419.5
605.0	3448.3
610.0	3477.1
615.0	3505.9
620.0	3534.7
625.0	3563.5
630.0	3592.3
635.0	3621.1
640.0	3649.9
645.0	3678.7
650.0	3707.5
655.0	3736.3
660.0	3765.1
665.0	3793.9
670.0	3822.7
675.0	3851.5
680.0	3880.3
685.0	3909.1
690.0	3937.9
695.0	3966.7
700.0	3995.5
705.0	4024.3
710.0	4053.1
715.0	4081.9
720.0	4110.7
725.0	4139.5
730.0	4168.3
735.0	4197.1
740.0	4225.9
745.0	4254.7
750.0	4283.5
755.0	4312.3
760.0	4341.1
765.0	4369.9
770.0	4398.7
775.0	4427.5
780.0	4456.3
785.0	4485.1
790.0	4513.9
795.0	4542.7
800.0	4571.5
805.0	4600.3
810.0	4629.1
815.0	4657.9
820.0	4686.7
825.0	4715.5
830.0	4744.3
835.0	4773.1
840.0	4801.9
845.0	4830.7
850.0	4859.5
855.0	4888.3
860.0	4917.1
865.0	4945.9
870.0	4974.7
875.0	5003.5
880.0	5032.3
885.0	5061.1
890.0	5089.9
895.0	5118.7
900.0	5147.5
905.0	5176.3
910.0	5205.1
915.0	5233.9
920.0	5262.7
925.0	5291.5
930.0	5320.3
935.0	5349.1
940.0	5377.9
945.0	5406.7
950.0	5435.5
955.0	5464.3
960.0	5493.1
965.0	5521.9
970.0	5550.7
975.0	5579.5
980.0	5608.3
985.0	5637.1
990.0	5665.9
995.0	5694.7
1000.0	5723.5

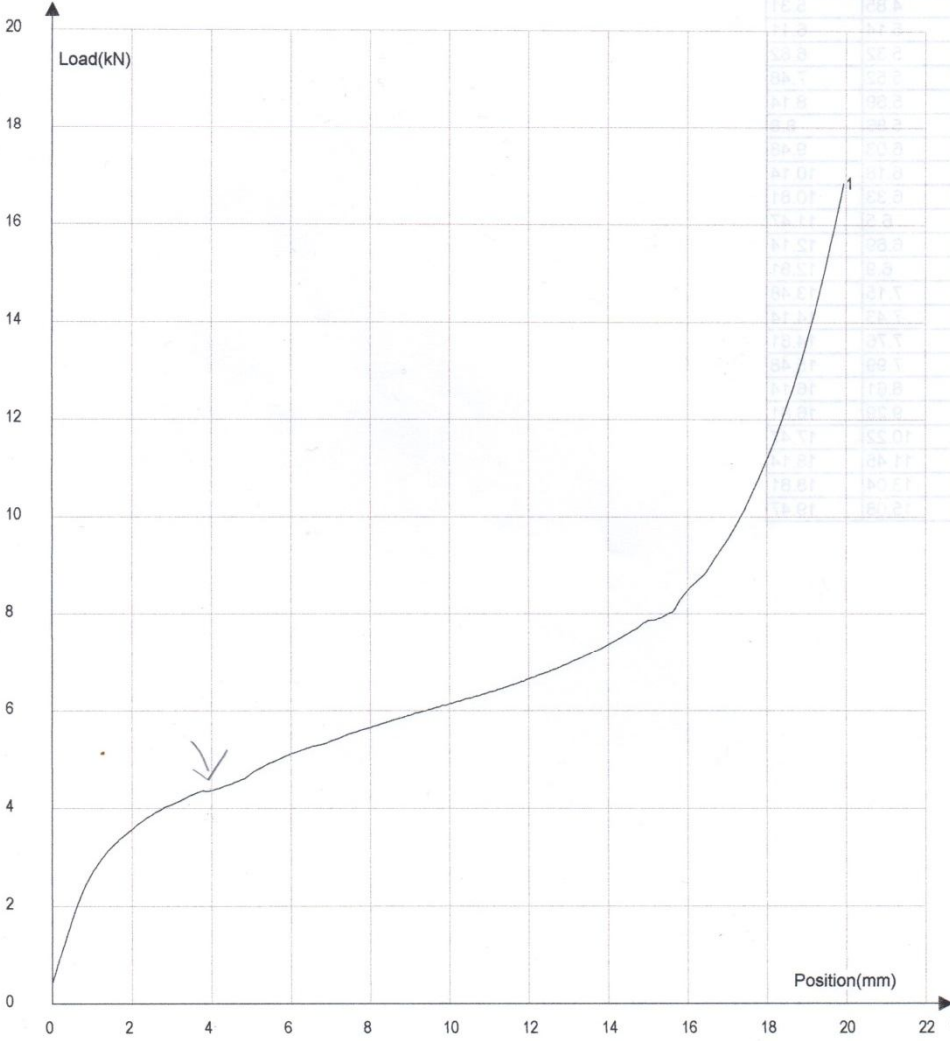

Tester:

Audit:

1/1

2

0) Testing Report

Gaya N	Defleksi mm
0.45	0.01
0.98	0.21
1.87	0.56
2.73	1.04
3.28	1.58
3.68	2.17
4.05	2.91
4.34	3.71
4.5	4.51
4.85	5.31
5.14	6.11
5.32	6.82
5.52	7.48
5.69	8.14
5.86	8.8
6.03	9.48
6.18	10.14
6.33	10.81
6.5	11.47
6.69	12.14
6.9	12.81
7.15	13.48
7.43	14.14
7.76	14.81
7.99	15.48
8.61	16.14
9.29	16.81
10.22	17.47
11.45	18.14
13.04	18.81
15.08	19.47

Compression Test(ASTM E910)Testing Report

Name	diameter of specimen(d)	maximum force(Fo)
ID	mm	kN
NO.1	12.70	9.59

Load(kN)	Displacement(mm)
0.0	0.0
0.5	0.1
1.0	0.2
1.5	0.3
2.0	0.4
2.5	0.5
3.0	0.6
3.5	0.7
4.0	0.8
4.5	0.9
5.0	1.0
5.5	1.1
6.0	1.2
6.5	1.3
7.0	1.4
7.5	1.5
8.0	1.6
8.5	1.7
9.0	1.8
9.5	1.9
10.0	2.0
10.5	2.1
11.0	2.2
11.5	2.3
12.0	2.4
12.5	2.5
13.0	2.6
13.5	2.7
14.0	2.8
14.5	2.9
15.0	3.0
15.5	3.1
16.0	3.2
16.5	3.3
17.0	3.4
17.5	3.5
18.0	3.6

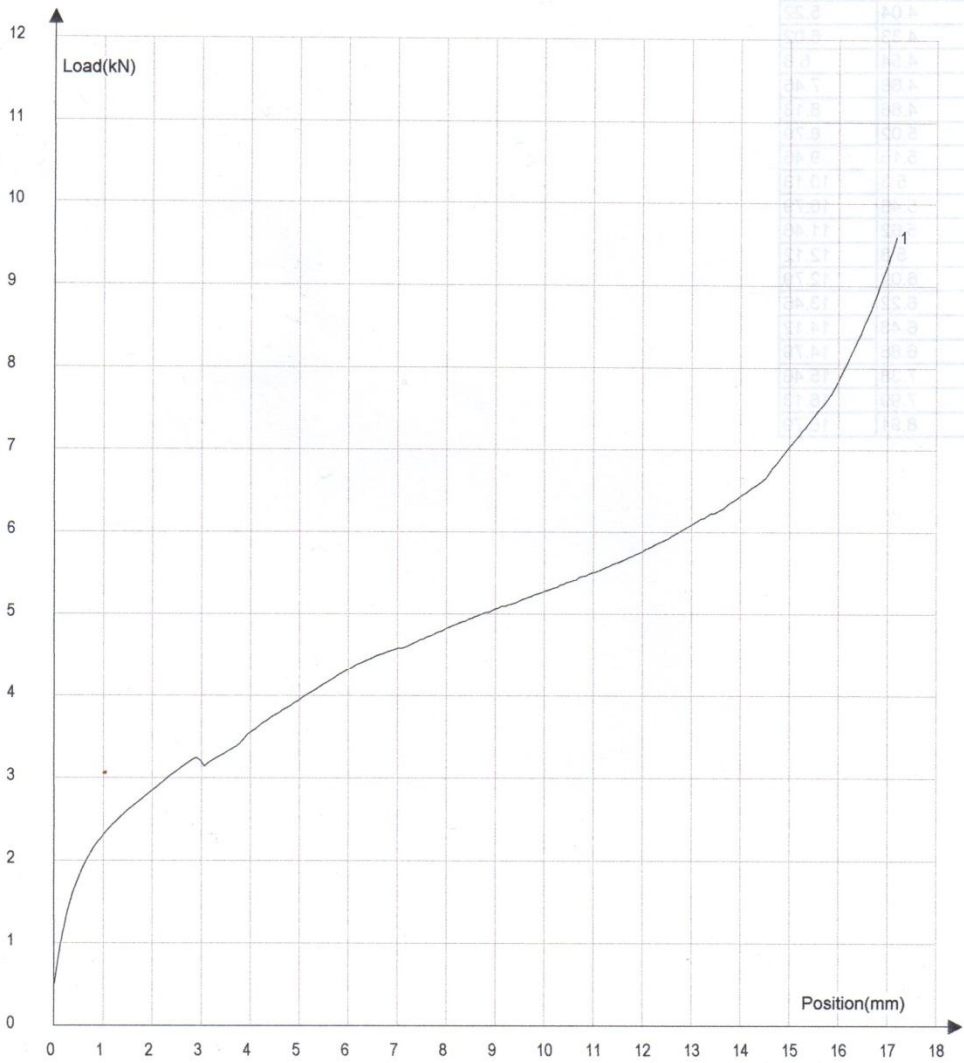

Tester:

Audit:

1/1

3

Gaya N	Defleksi mm
0.51	0.01
1.19	0.2
1.84	0.53
2.3	0.99
2.62	1.52
2.9	2.1
3.22	2.82
3.35	3.62
3.73	4.42
4.04	5.22
4.33	6.02
4.54	6.8
4.68	7.46
4.86	8.13
5.02	8.79
5.15	9.46
5.3	10.13
5.46	10.79
5.62	11.46
5.8	12.12
6.02	12.79
6.22	13.46
6.48	14.12
6.88	14.79
7.38	15.46
7.99	16.13
8.91	16.79

Compression Test(ASTM E910)Testing Report

Name	diameter of specimen(d)	maximum force(Fo)
ID	mm	kN
NO.1	12.70	9.13

Deflex	Force
mm	kN
0.01	0.36
0.21	0.86
0.53	1.3
1.03	1.81
1.58	2.3
2.15	2.8
2.88	3.3
3.63	3.8
4.48	4.3
5.38	4.8
6.38	5.3
7.53	5.8
8.8	6.3
10.1	6.8
11.5	7.3
13.0	7.8
14.5	8.3
16.0	8.8
17.5	9.13

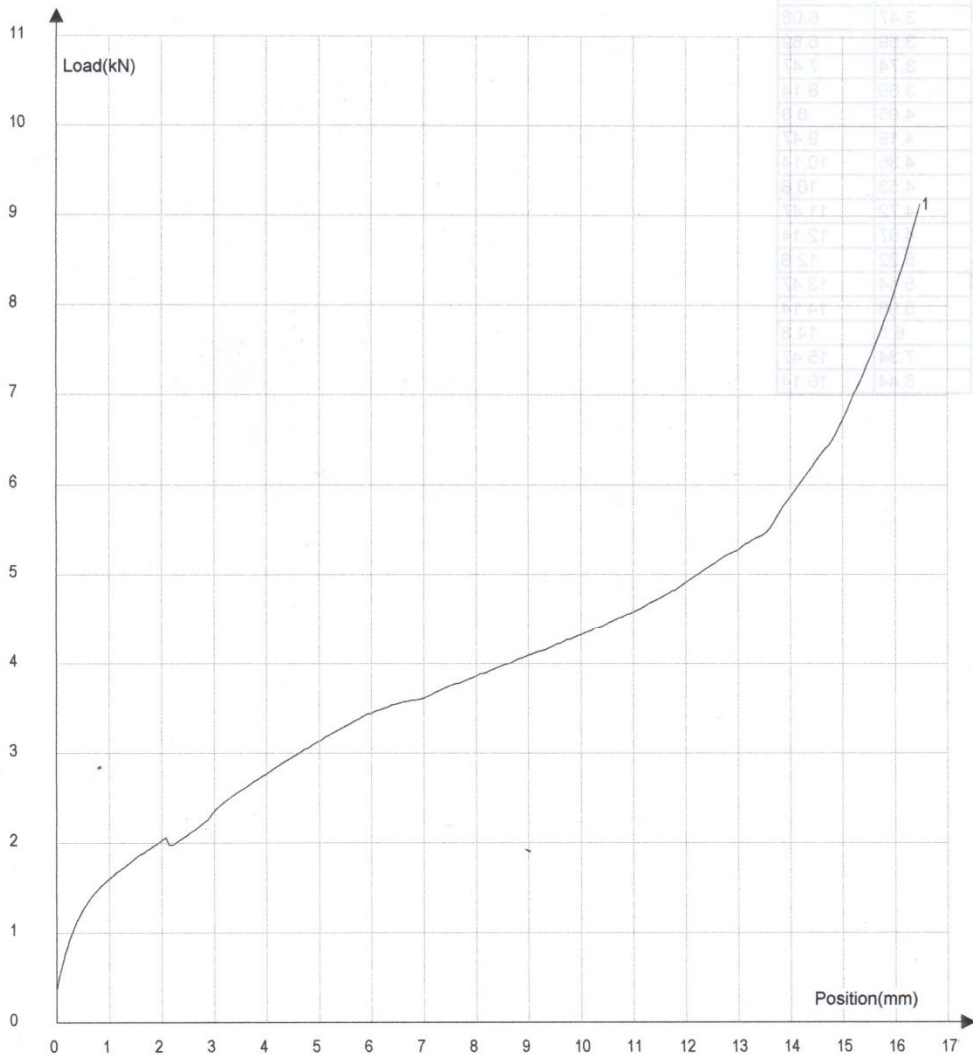

Tester:

Audit:

1/1

4

0) Testing Report

Gaya N	Defleksi mm
0.38	0.01
0.86	0.21
1.3	0.55
1.61	1.03
1.85	1.56
1.98	2.15
2.26	2.88
2.65	3.68
2.95	4.48
3.23	5.28
3.47	6.08
3.59	6.82
3.74	7.47
3.89	8.14
4.05	8.8
4.19	9.47
4.36	10.14
4.53	10.8
4.72	11.47
4.97	12.14
5.22	12.8
5.44	13.47
5.98	14.14
6.5	14.8
7.34	15.47
8.44	16.14

Compression Test(ASTM E910)Testing Report

Name	diameter of specimen(d)	maximum force(Fo)
ID	mm	kN
NO.1	12.70	7.47

Displacement (mm)	Load (kN)
0.00	0.00
0.25	1.50
0.50	2.50
0.75	2.80
1.00	2.90
1.25	2.80
1.50	2.90
1.75	3.00
2.00	3.10
2.25	3.20
2.50	3.30
2.75	3.40
3.00	3.50
3.25	3.60
3.50	3.70
3.75	3.80
4.00	3.90
4.25	4.00
4.50	4.10
4.75	4.20
5.00	4.30
5.25	4.40
5.50	4.50
5.75	4.60
6.00	4.70
6.25	4.80
6.50	4.90
6.75	5.00
7.00	5.10
7.25	5.20
7.50	5.30
7.75	5.40
8.00	5.50
8.25	5.60
8.50	5.70
8.75	5.80
9.00	5.90
9.25	6.00
9.50	6.10
9.75	6.20
10.00	6.30
10.25	6.40
10.50	6.50
10.75	6.60
11.00	6.70
11.25	6.80
11.50	6.90
11.75	7.00
12.00	7.10
12.25	7.20
12.50	7.30
12.75	7.40
13.00	7.47

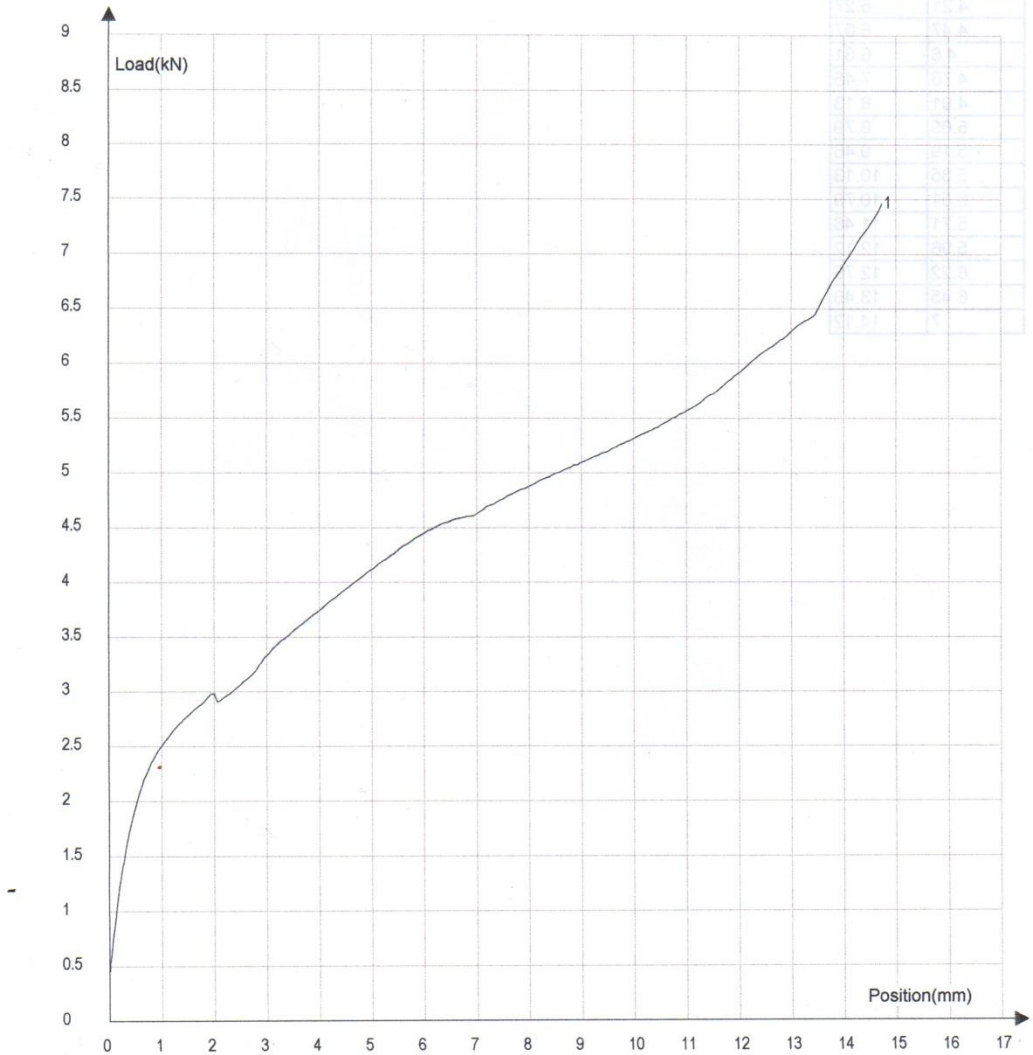

Tester:

Audit:

11

Testing Report

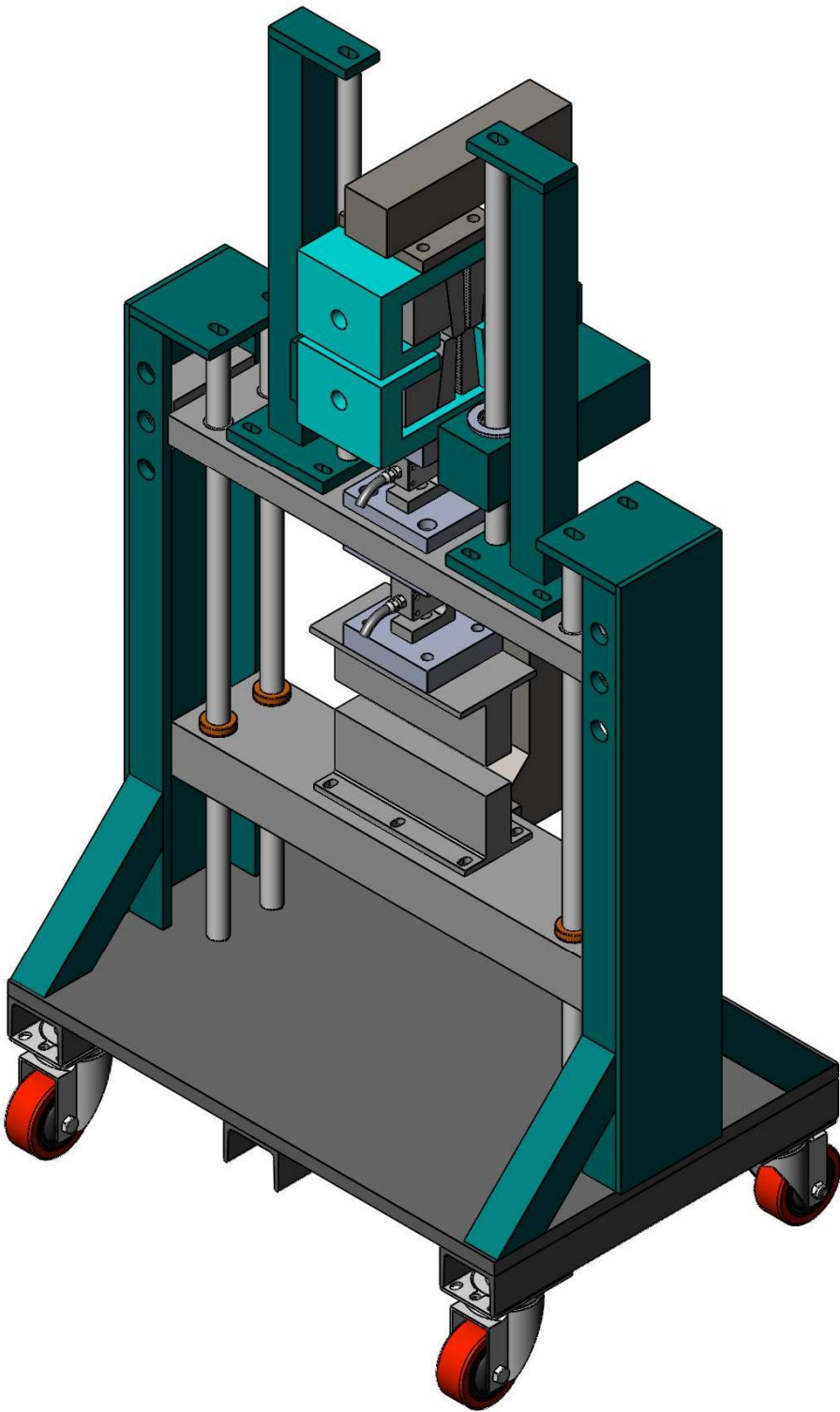

Gaya kN	Defleksi mm
0	0
13.26	0.23
23.69	0.84
36.95	1.8
50.69	3.02
64.43	4.33
71.06	5.63
77.69	6.93
88.11	8.24
81.01	9.54
91.43	10.84
88.11	12.14
94.74	13.45
84.8	14.75
84.8	16.05
81.01	17.36
84.8	18.66
81.01	19.96
81.01	21.26
74.37	22.57
77.69	23.87
74.37	25.17
64.43	26.47
64.43	27.77
57.32	29.08
60.64	30.38
54	31.68
47.37	32.98
47.37	34.29
40.27	35.59
44.06	36.89

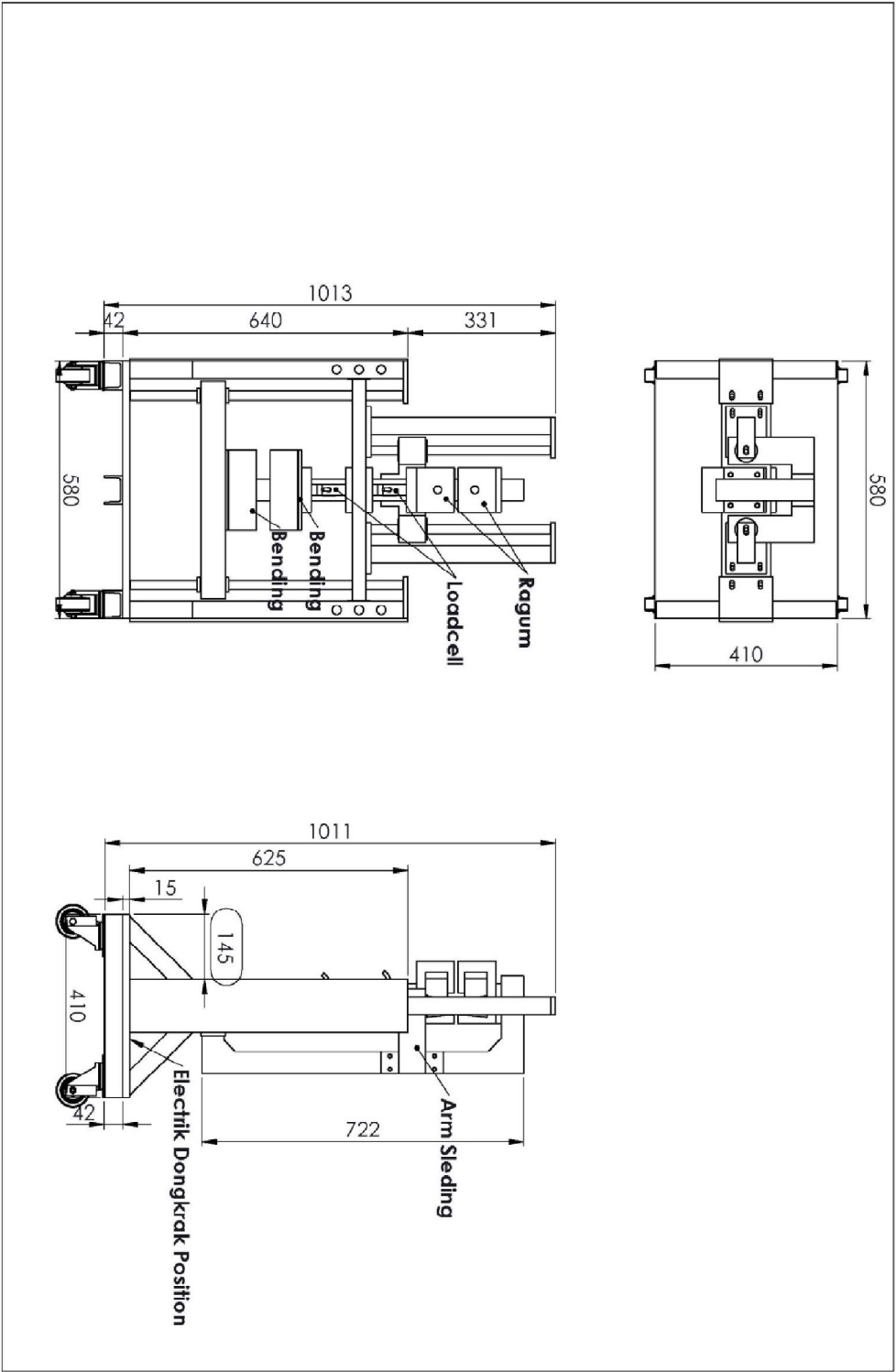

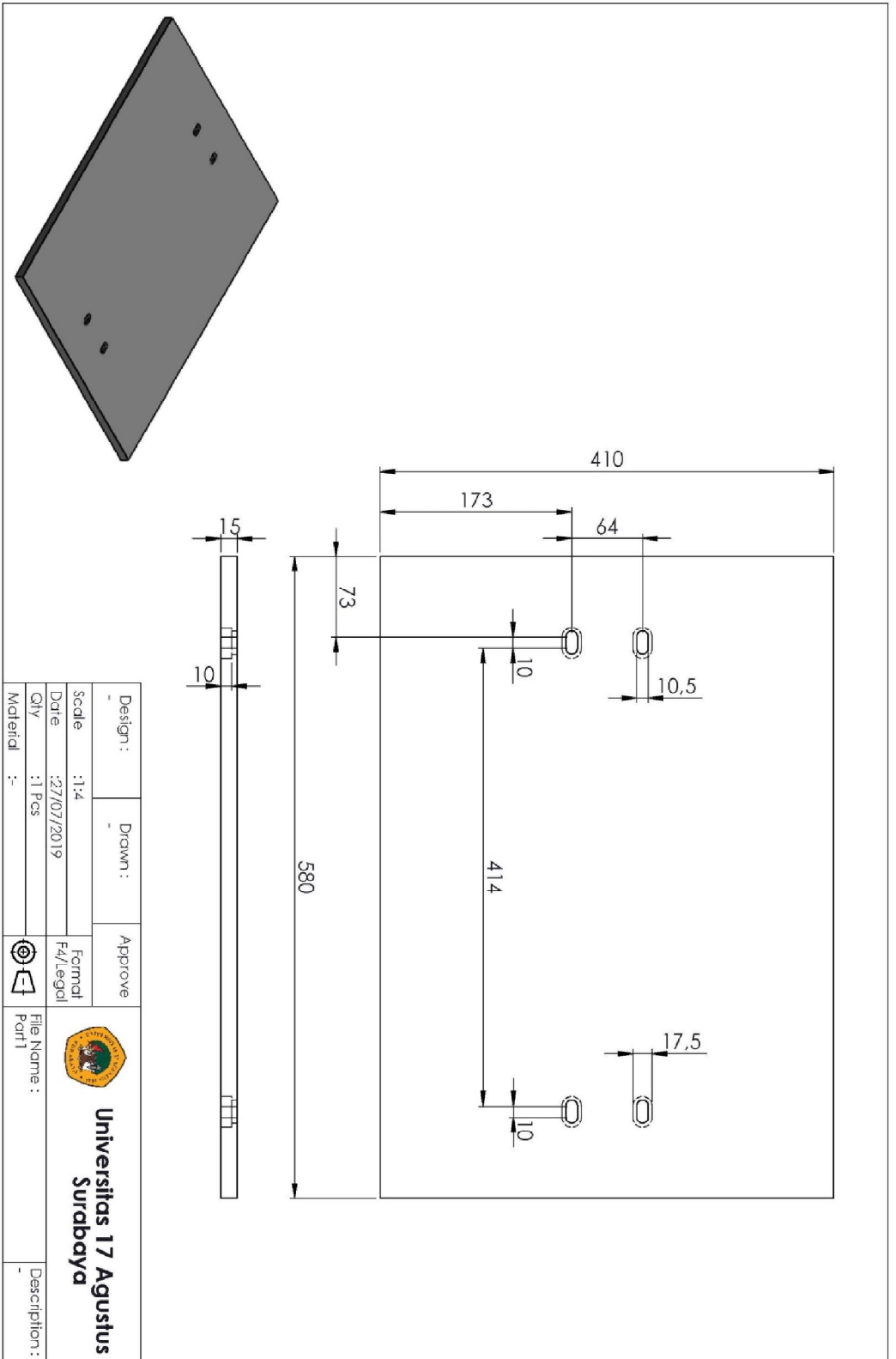

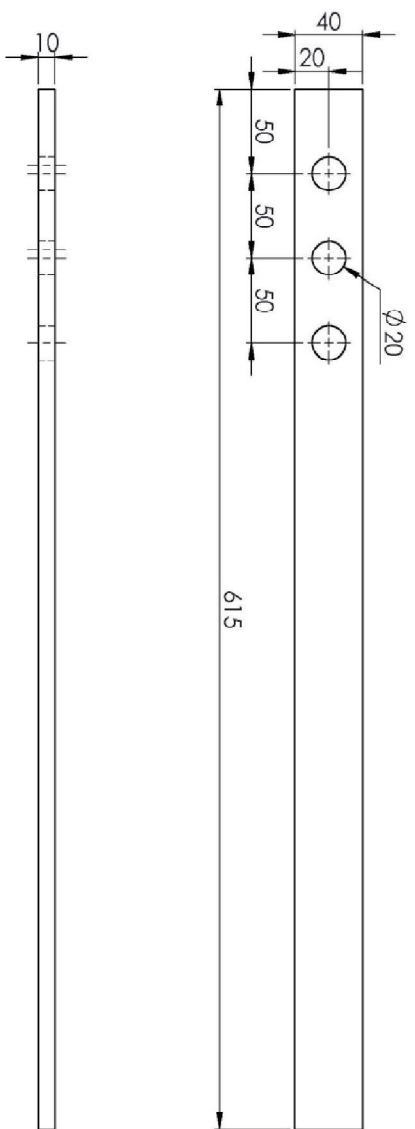





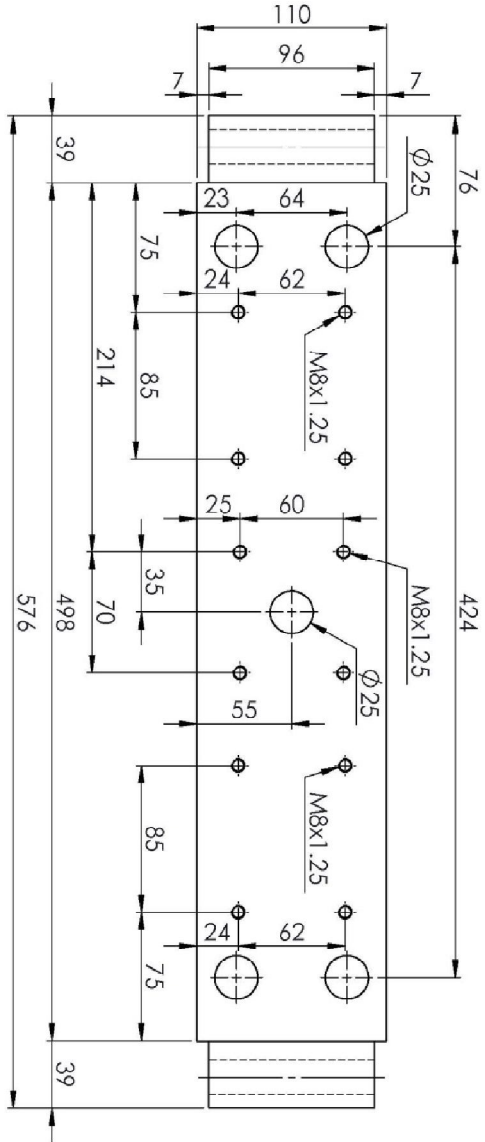
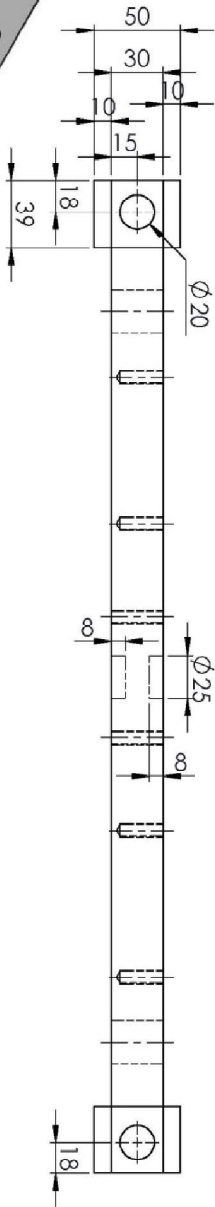
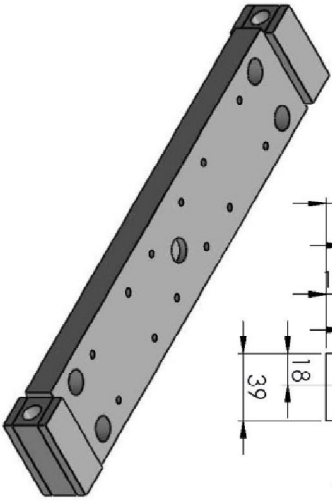

Design :	Drawn :	Approve	 Universitas 17 Agustus Surabaya	Description :
Scale : 1:3		Format F4/Legal		
Date : 27/07/2019				
Qty : 4 Pcs				
Material :				
		 	File Name : Part2	

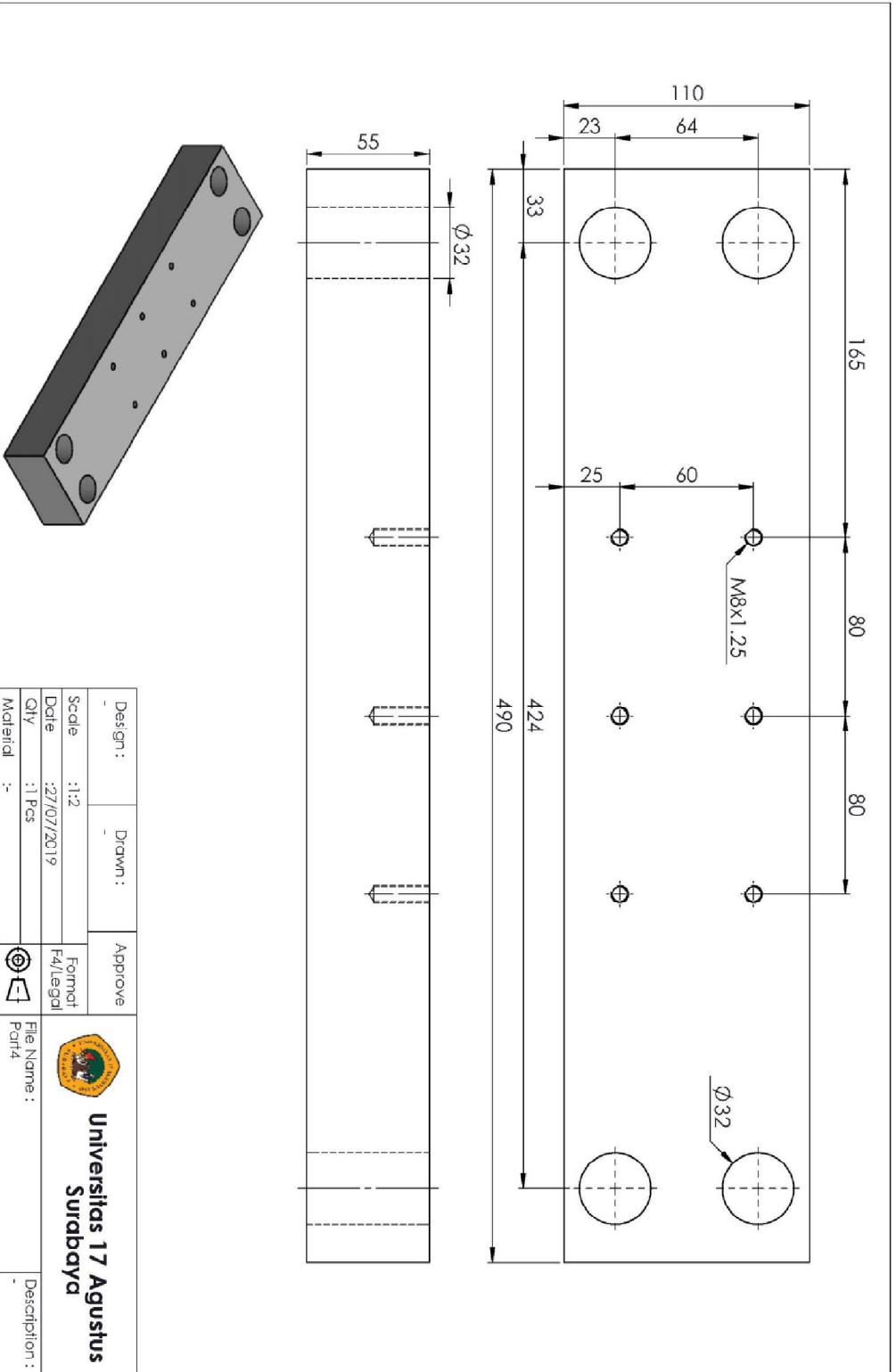

Design :	Drawn :	Approve	 Universitas 17 Agustus Surabaya	Description :
Scale : 1:3	Format : F4/legal			
Date : 27/07/2019	File Name : Parts			
Qty : 1 Pcs				
Material : -				

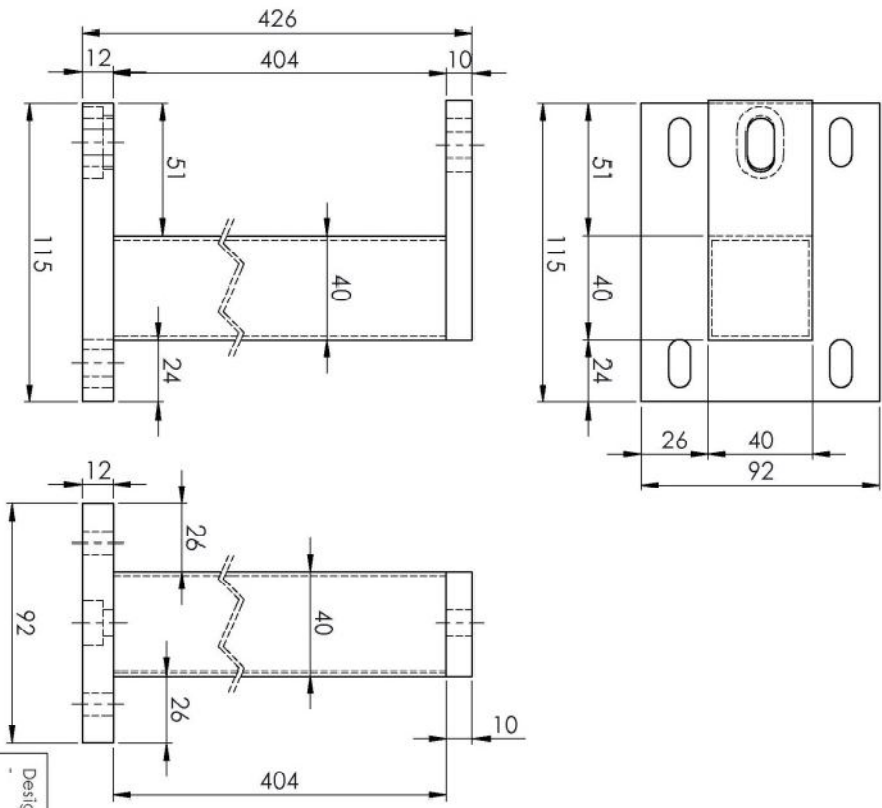



Design :	Drawn :	Approve :	 Universitas 17 Agustus Surabaya	Description :
Scale : 1:10		Formul F4/Legal		
Date : 12/08/2019				
Qty : 1 Pcs				
Material :-			File Name : Assen3	