

## LAMPIRAN PROSES PEMBUATAN MESIN



Proses pemotongan plat casing belt conveyor



Perakitan casing belt conveyor.



Pengelasan roda mesin.



Proses pembuatan screw.





Proses pengecatan mesin.



Proses pengecatan casing belt conveyor.





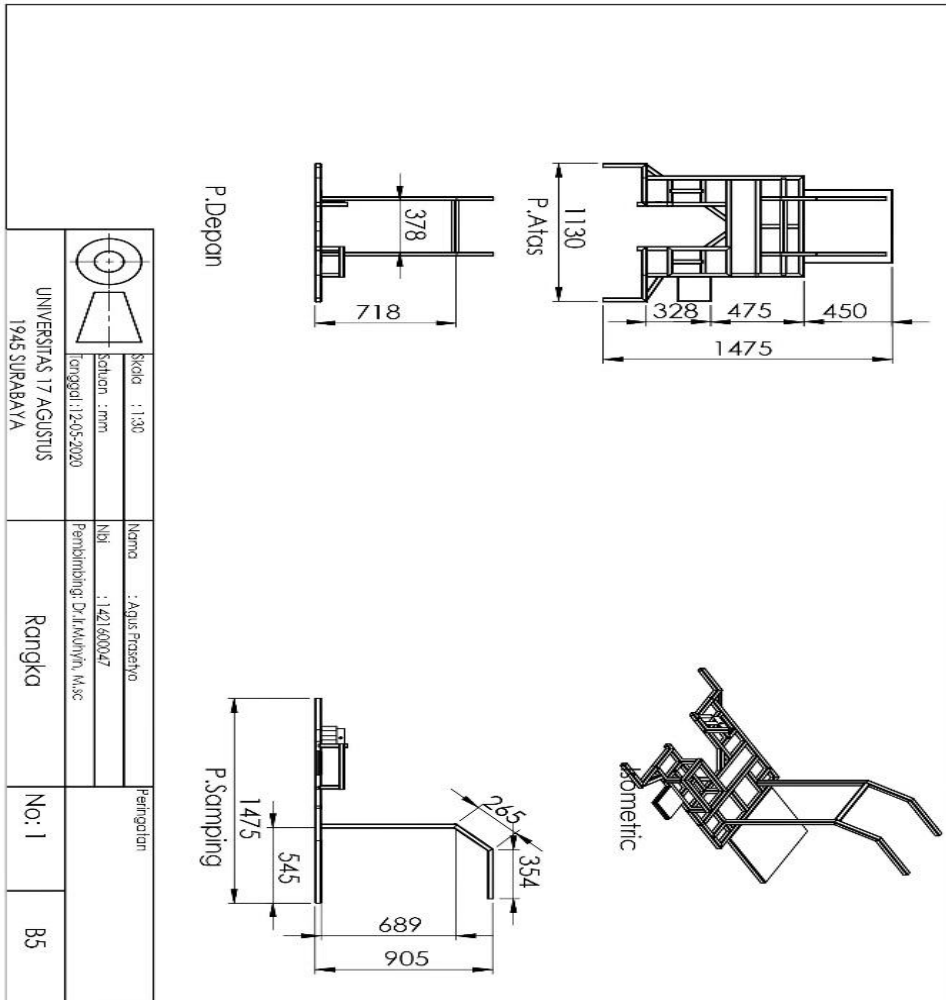

Gambar teknik kerangka mesin.

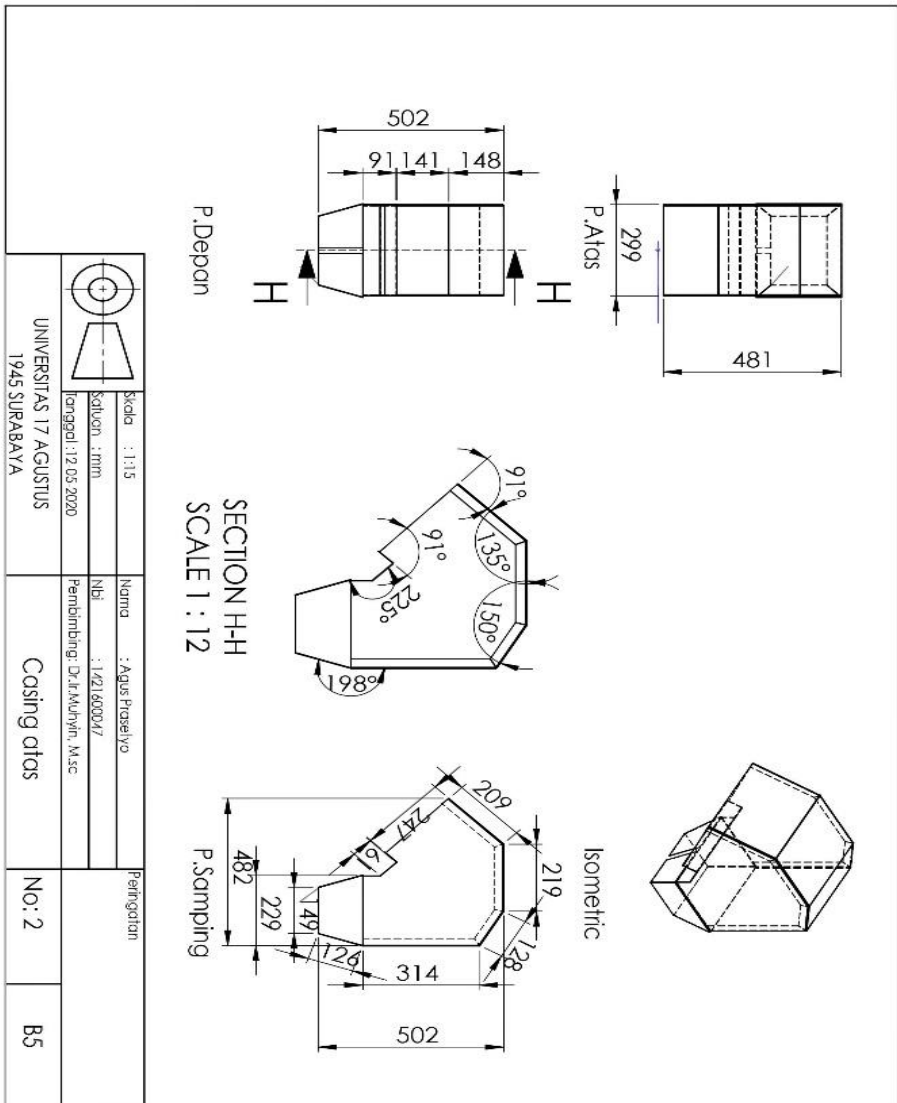

Gambar teknik casing atas.

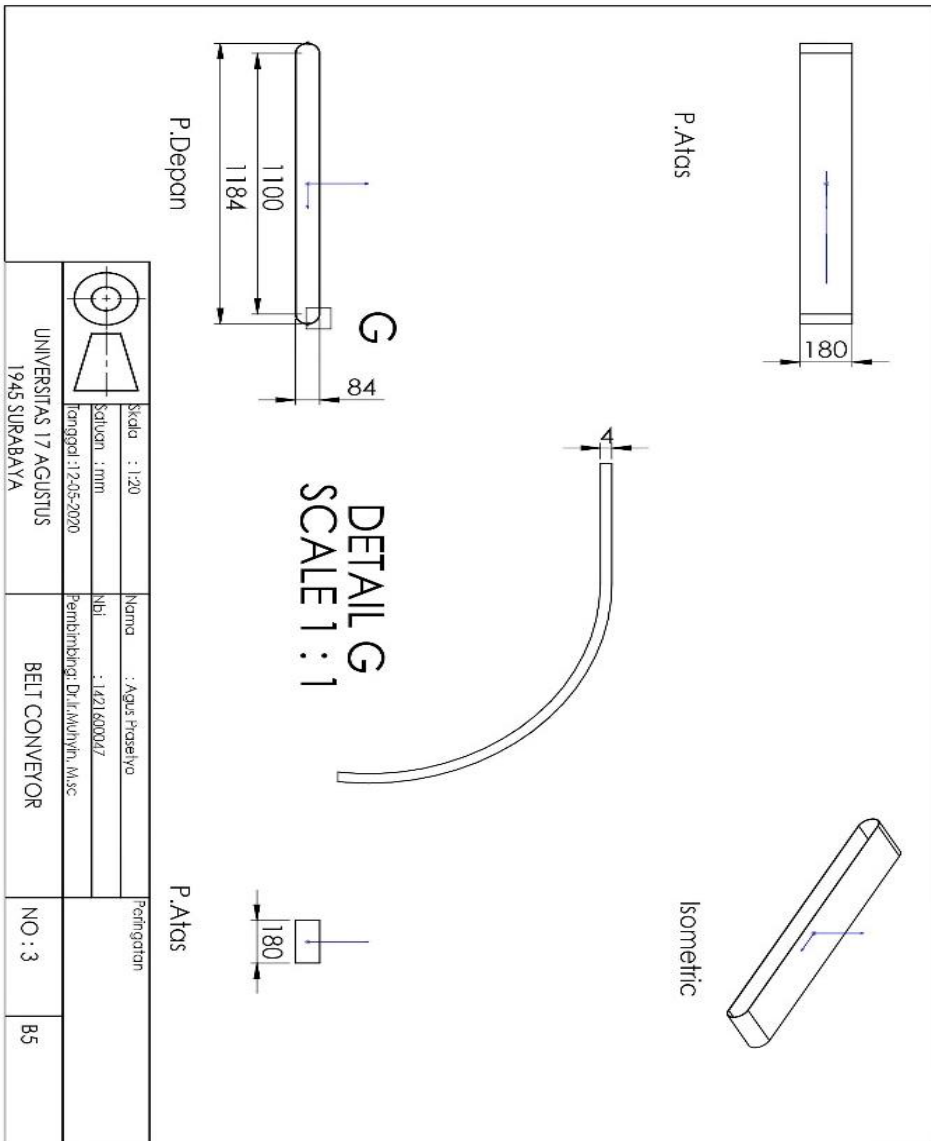

Gambar teknik belt conveyor.



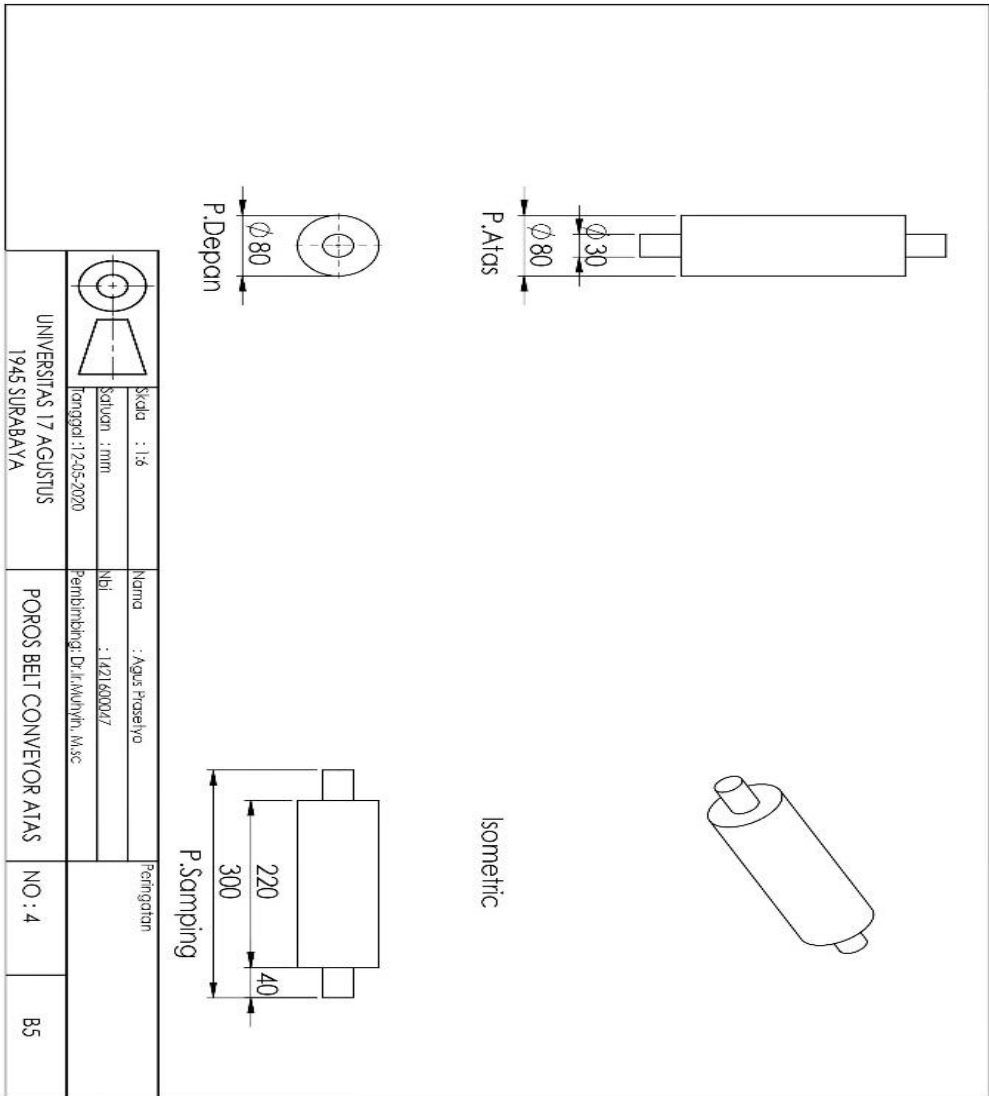

Gambar teknik poros atas belt conveyor.

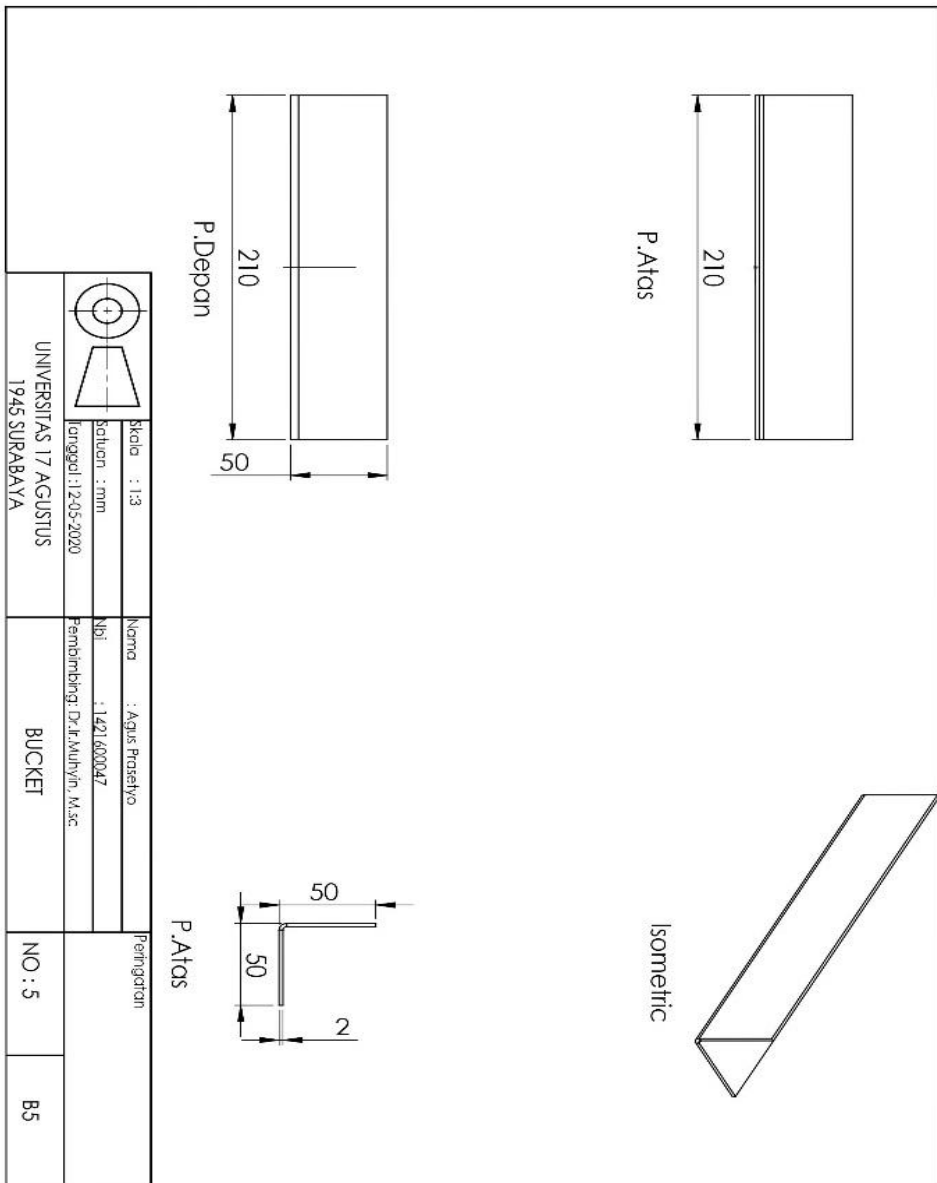

Gambar teknik bucket elevator.

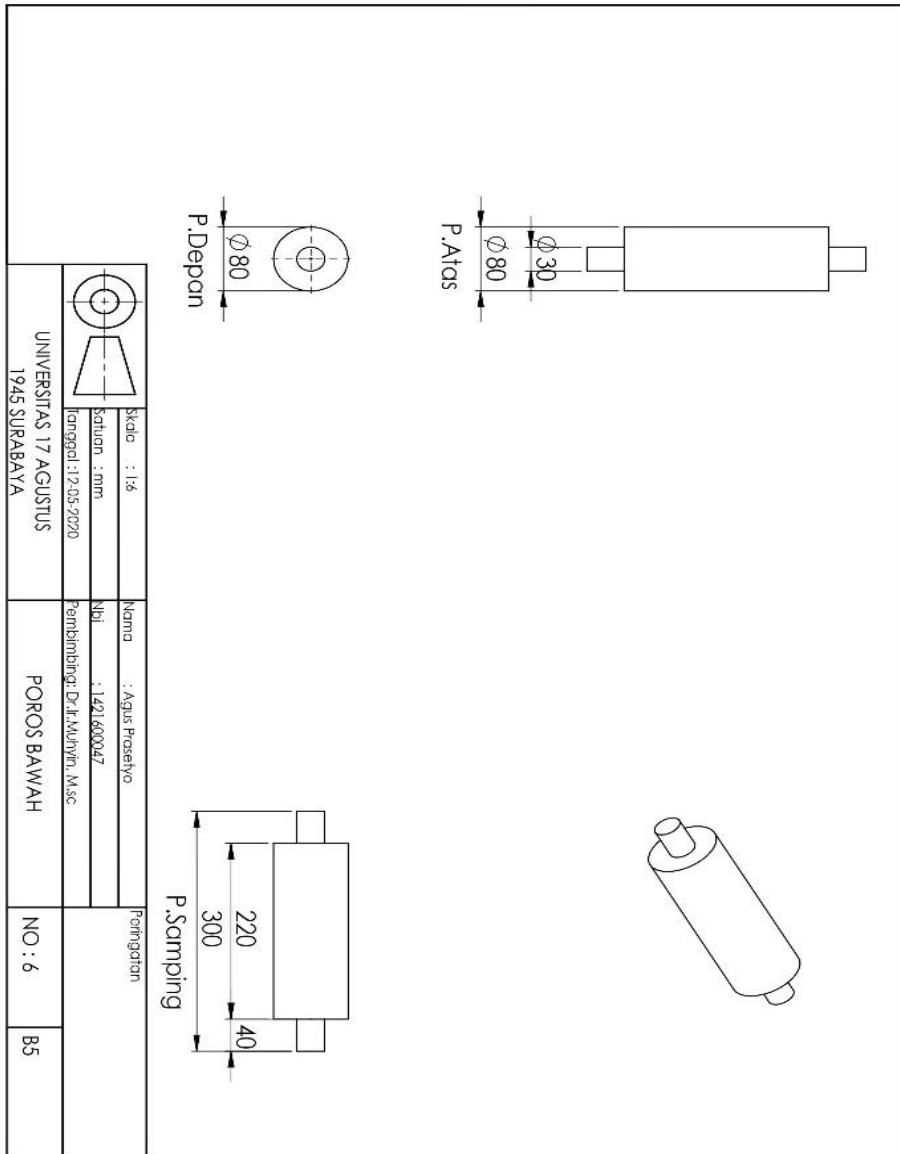

Gambar teknik poros bawah belt conveyor.

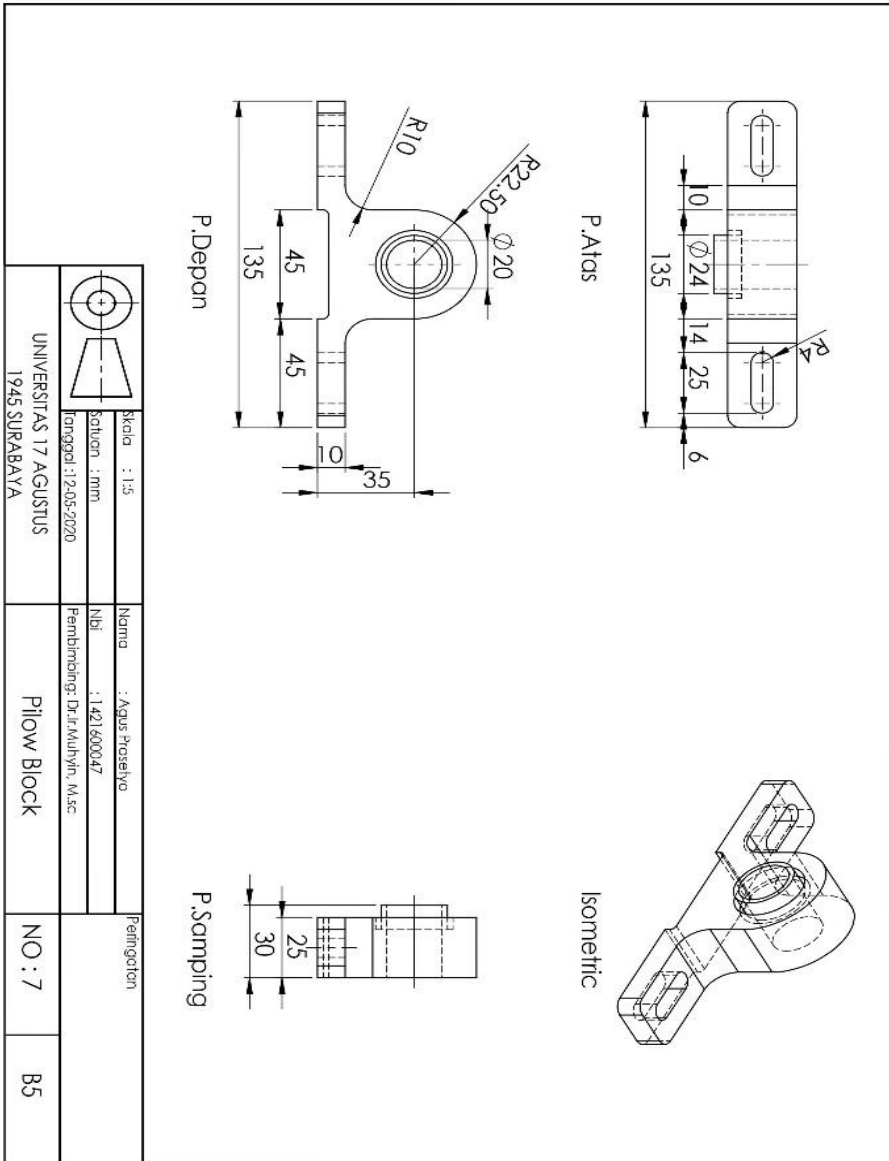

Gambar teknik pillow block.

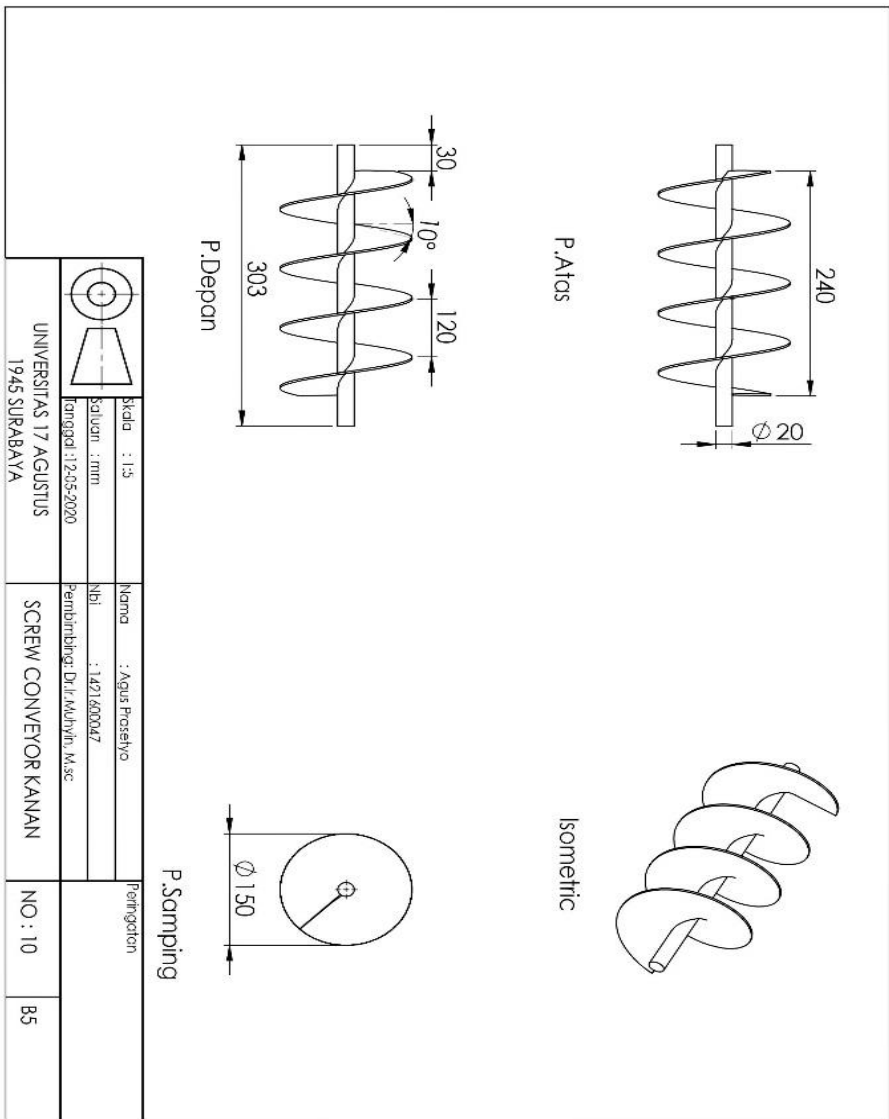

Gambar teknik screw conveyor kanan.



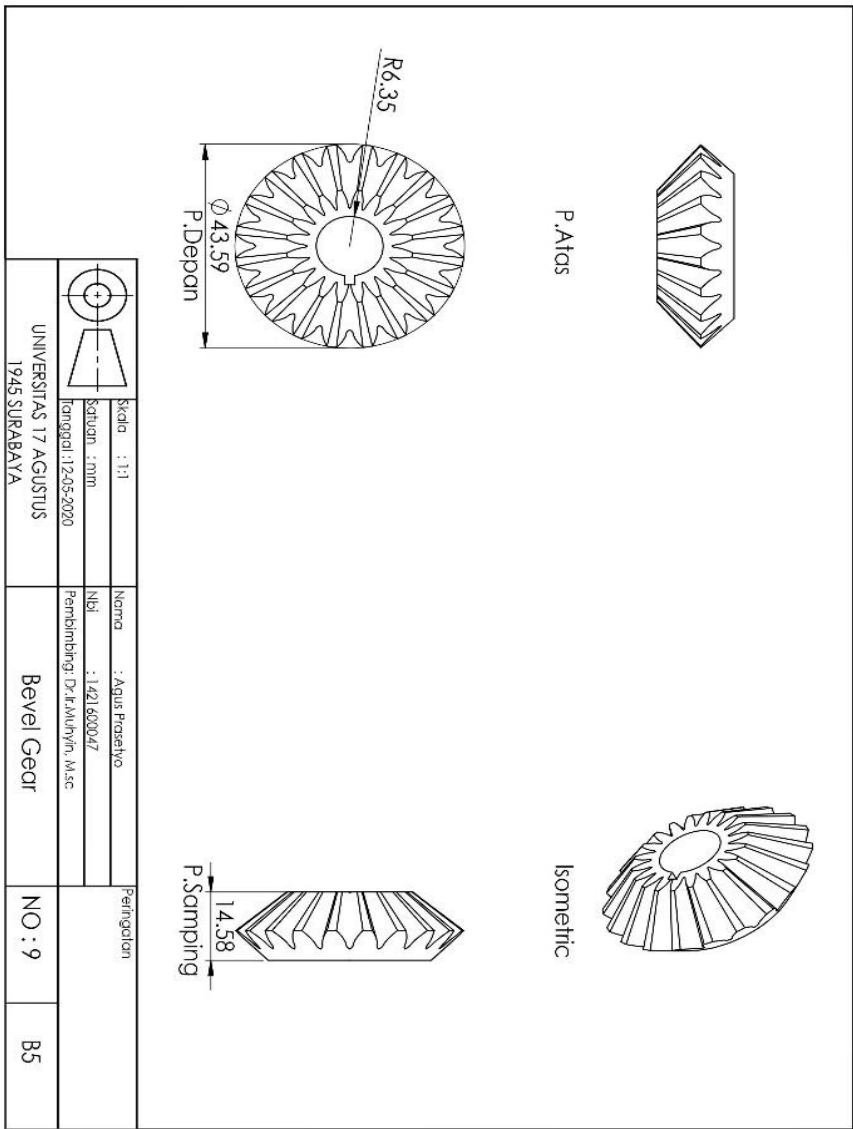

Gambar teknik bevel gear.

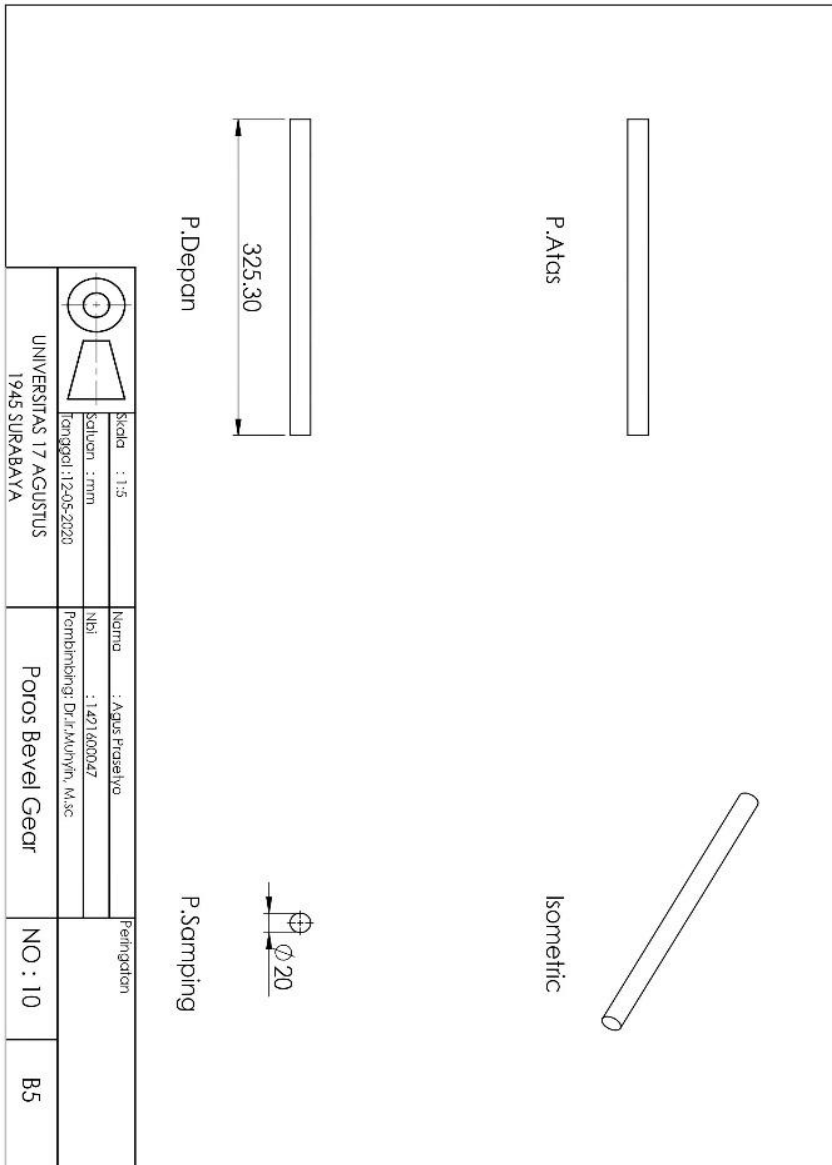

Gambar teknik poros bevel gear.

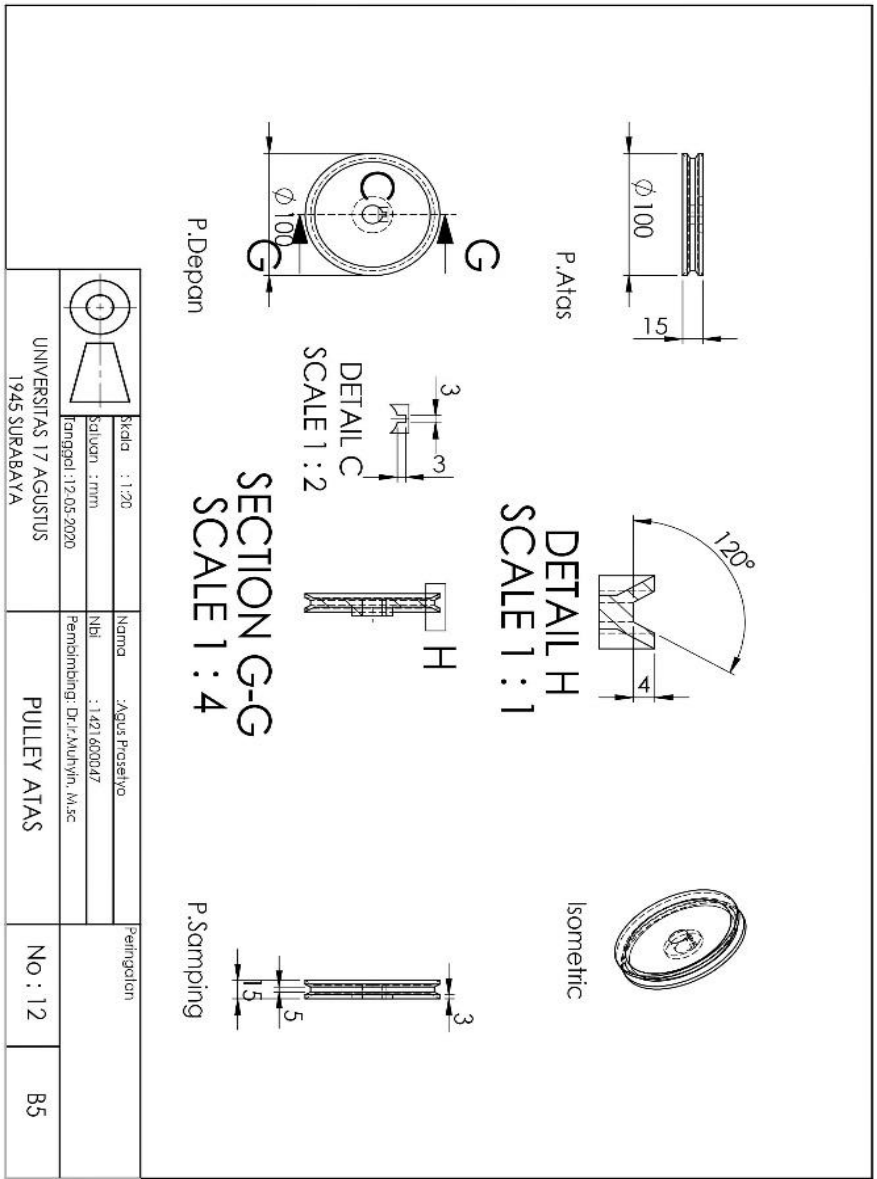

Gambar teknik pulley atas.

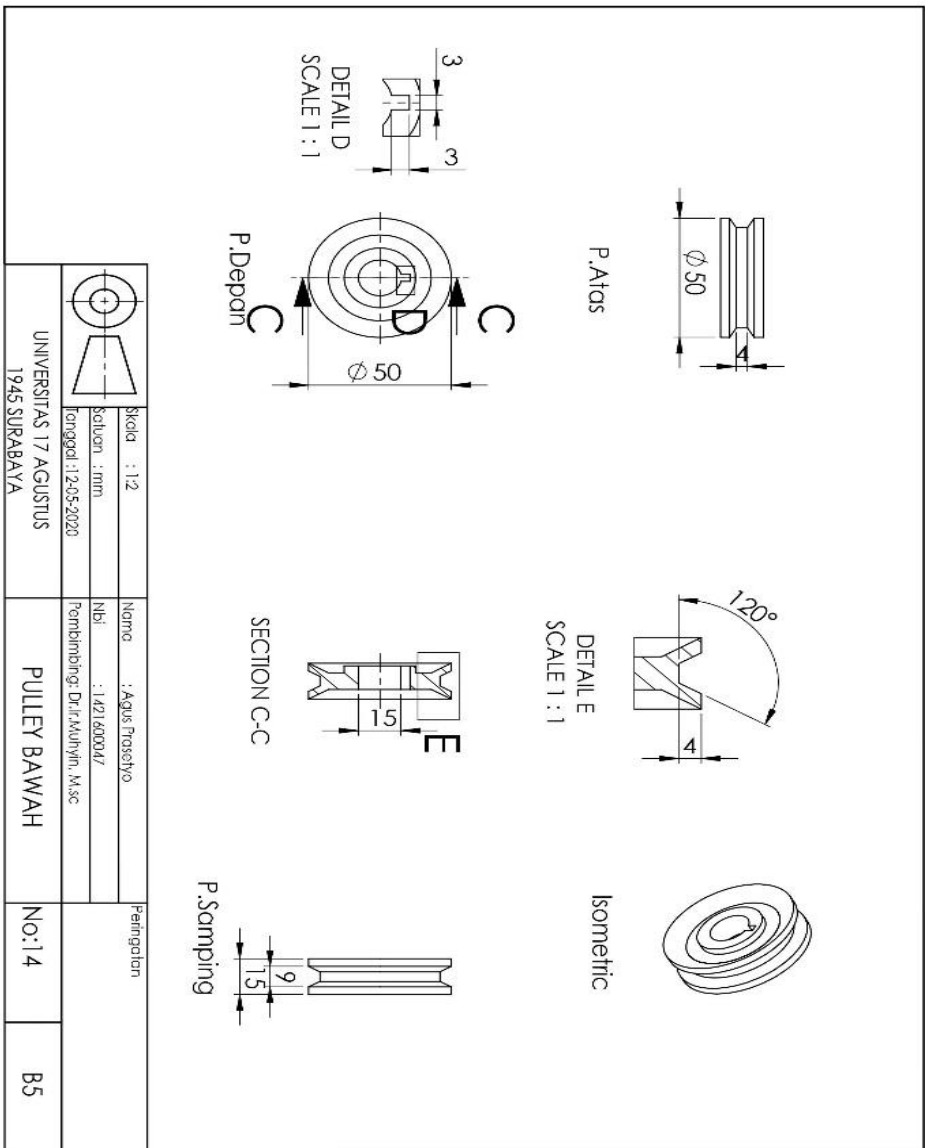

Gambar teknik pulley bawah.

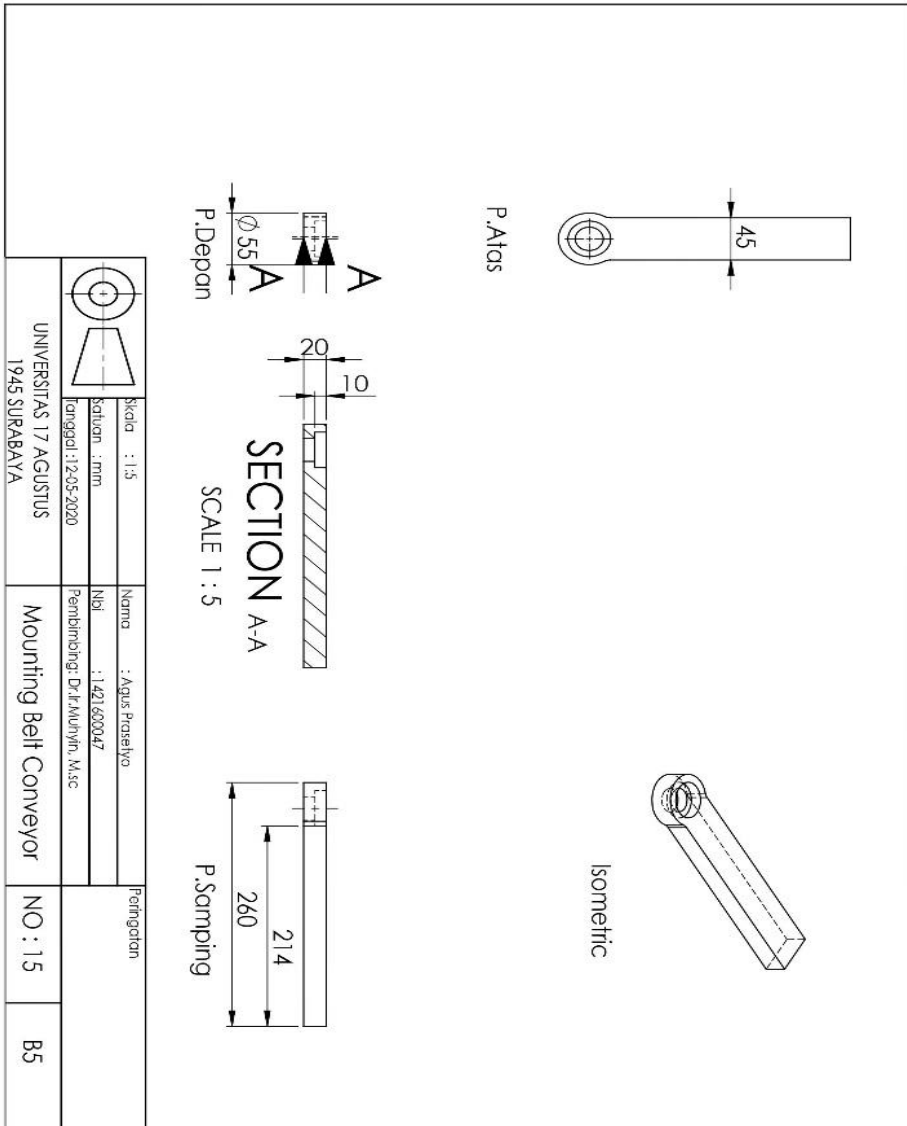

Gambar teknik mounting belt conveyor.



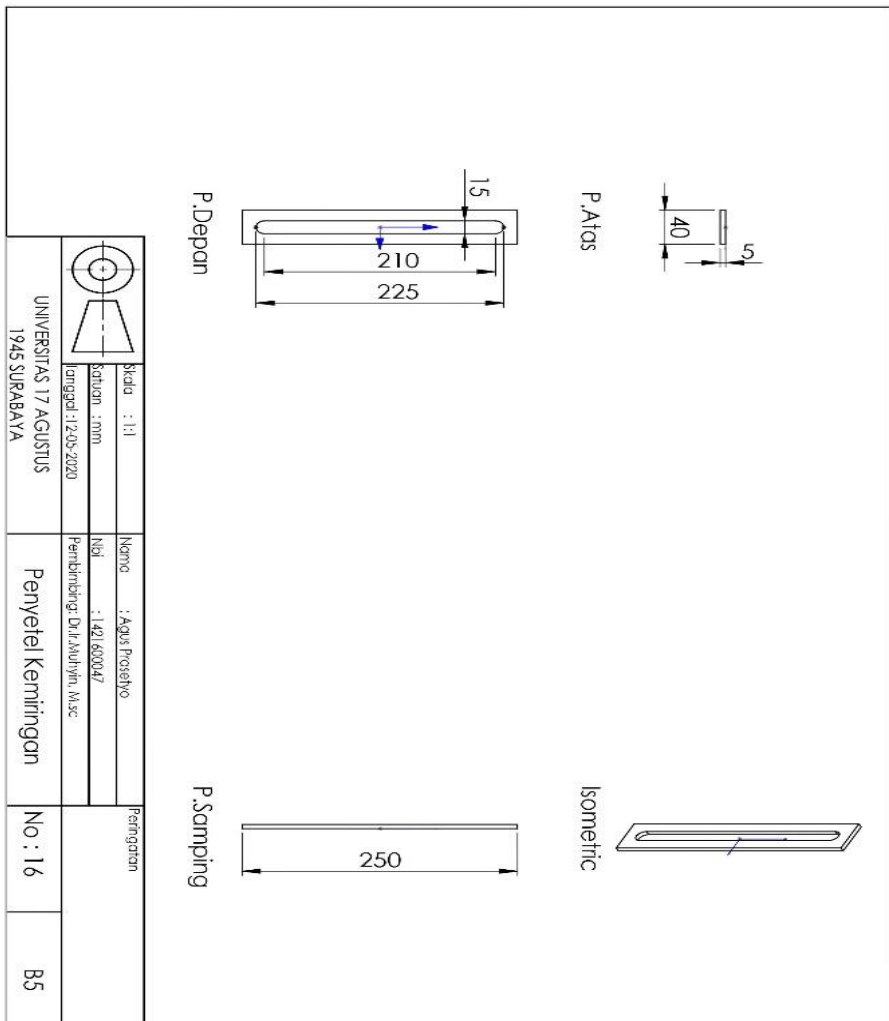

Gambar teknik penyetel kemiringan.

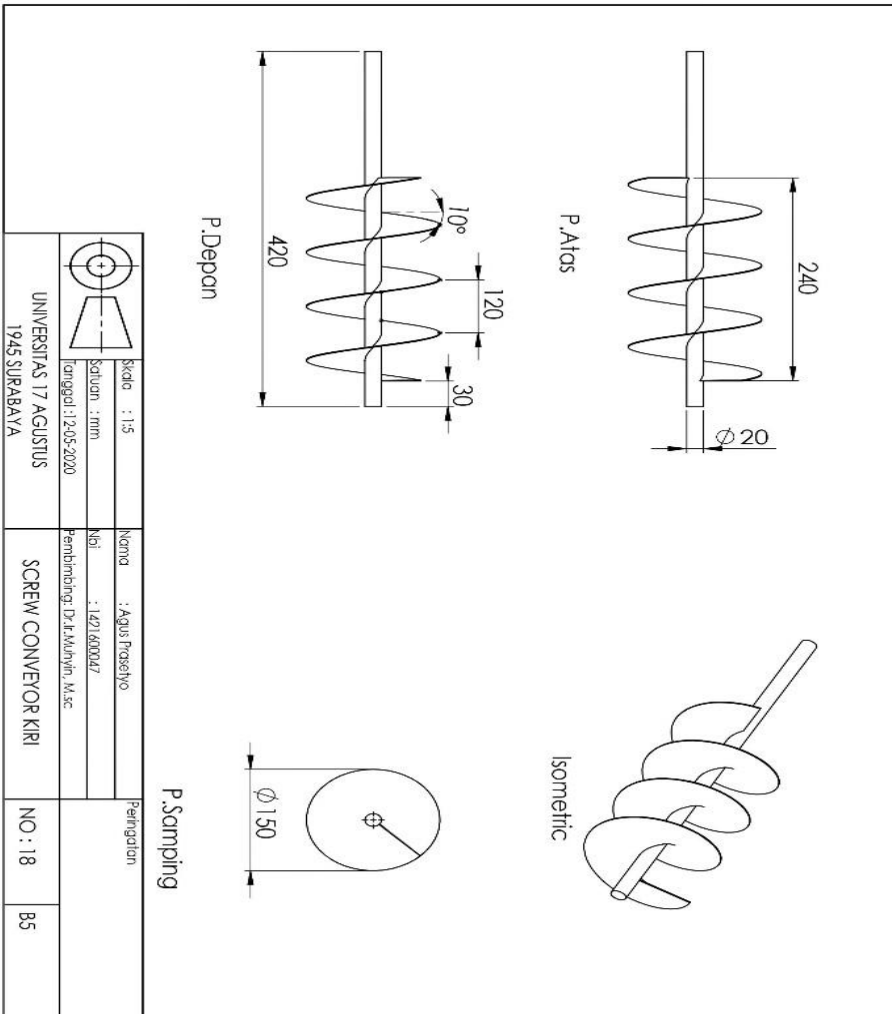

Gambar teknik screw conveyor kiri.

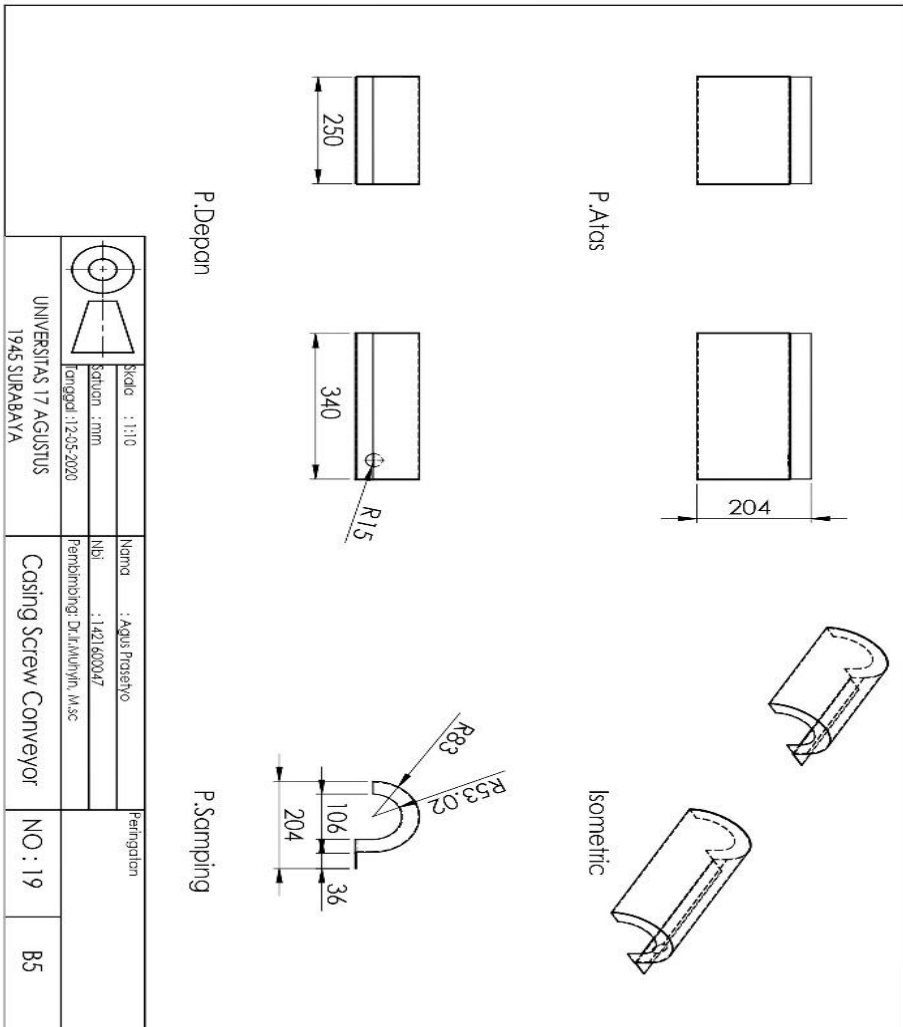

Gambar teknik casing screw conveyor.

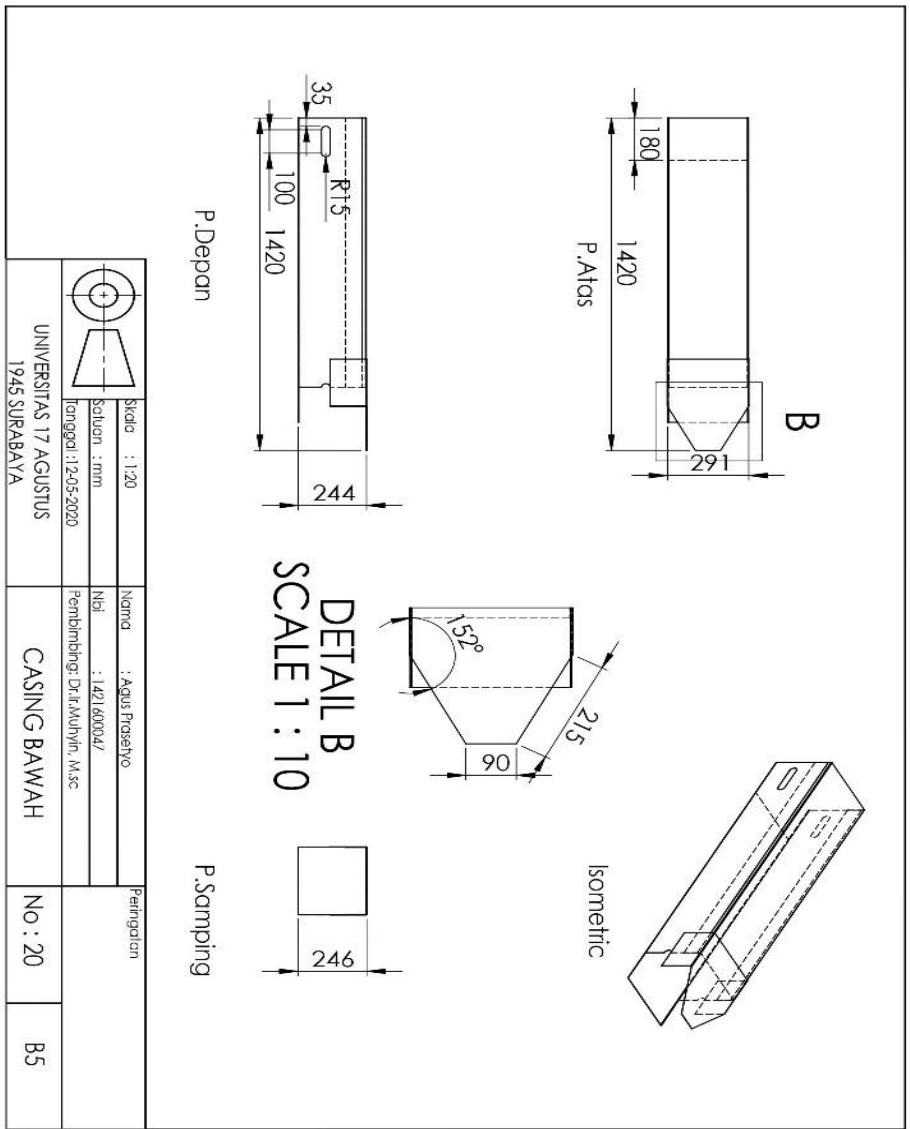

Gambar teknik casing bawah.