

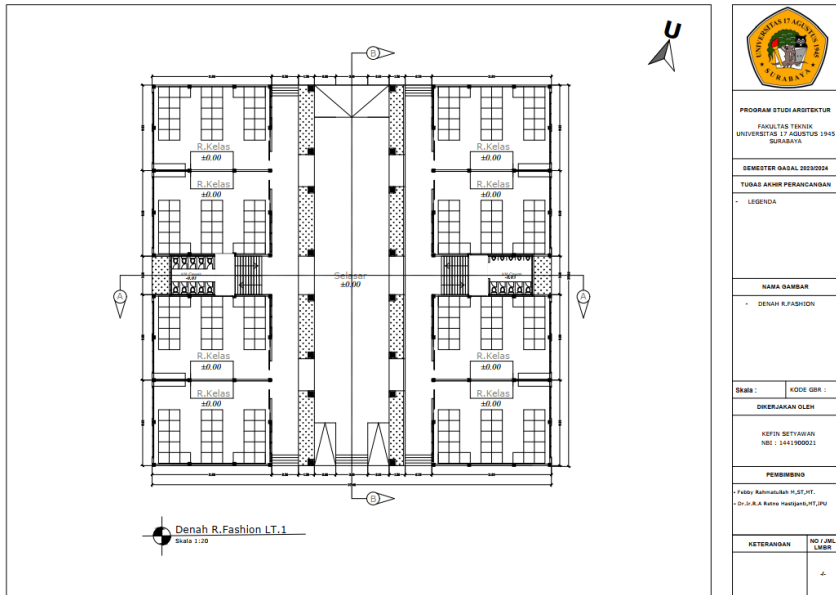





Gambar 6.2.3 Tampak Bangunan Utama

Sumber : Penulis

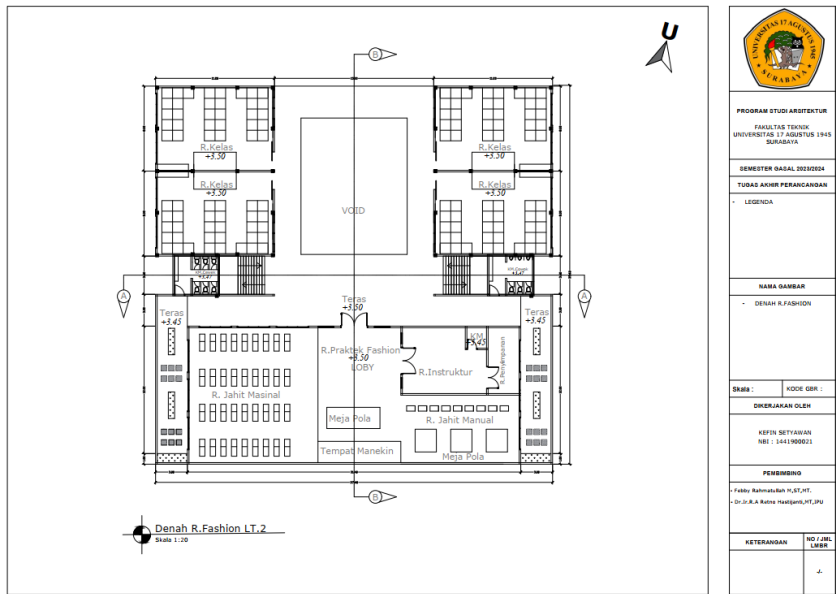

	
PROGRAM STUDI ARSITEKTUR FAKULTAS TEKNIK UNIVERSITAS 17 AGUSTUS 1945 SURABAYA	
SEMESTER GASAL 2023/2024 TUGAS AKHIR PERANCANGAN	
LEGENDA	
NAMA GAMBAR DENAH R.FASHION	
SKEMA :	KODE GBR :
DIBERIKAN OLEH	
KEFIN SETYAWAN NRI : 1441900021	
PEMBIMBING Fakhri Rahmatullah H,ST,MT, Dr. D. B. A. Rofiqo Hoesniqah,MT,PU	
KETERANGAN	NO / JML LEMBAR
	1 / 1



	
PROGRAM STUDI ARSITEKTUR FAKULTAS TEKNIK UNIVERSITAS 17 AGUSTUS 1945 SURABAYA	
SEMESTER GASAL 2023/2024 TUGAS AKHIR PERANCANGAN	
LEGENDA	
NAMA GAMBAR DENAH R.FASHION	
SKEMA :	KODE GBR :
DIBERIKAN OLEH	
KEFIN SETYAWAN NRI : 1441900021	
PEMBIMBING Fakhri Rahmatullah H,ST,MT, Dr. D. B. A. Rofiqo Hoesniqah,MT,PU	
KETERANGAN	NO / JML LEMBAR
	1 / 1

Gambar 6.2.4 Denah Ruang Fashion

Sumber : Penulis



	
PROGRAM STUDI ARSITEKTUR FAKULTAS TEKNIK UNIVERSITAS 17 AGUSTUS 1945 SURABAYA	
SEMESTER GASAL 2020/2024 TUGAS AKHIR PERANCANGAN	
LEGENDA	
NAMA GAMBAR	
POTONGAN R.FASHION	
Skala :	KODE GER :
Dikerjakan oleh	
KEVIN SETYAWAN NBI : 1441900021	
PEMBimbing	
- Febby Rahmawati M.Sc.IT, - Dr. Ir. A. Ratno Harjono M.T., Ph.D.	
KETERANGAN	NO. JML. LEMBAR
	1

Gambar 6.2.5 Potongan Ruang Fashion

Sumber : Penulis



	
PROGRAM STUDI ARSITEKTUR FAKULTAS TEKNIK UNIVERSITAS 17 AGUSTUS 1945 SURABAYA	
SEMESTER GASAL 2020/2024 TUGAS AKHIR PERANCANGAN	
LEGENDA	
NAMA GAMBAR	
TAMPAK RUANG FASHION	
Skala :	KODE GER :
Dikerjakan oleh	
KEVIN SETYAWAN NBI : 1441900021	
PEMBimbing	
- Febby Rahmawati M.Sc.IT, - Dr. Ir. A. Ratno Harjono M.T., Ph.D.	
KETERANGAN	NO. JML. LEMBAR
	1



Gambar 6.2.6 Tampak Ruang Fashion

Sumber : Penulis

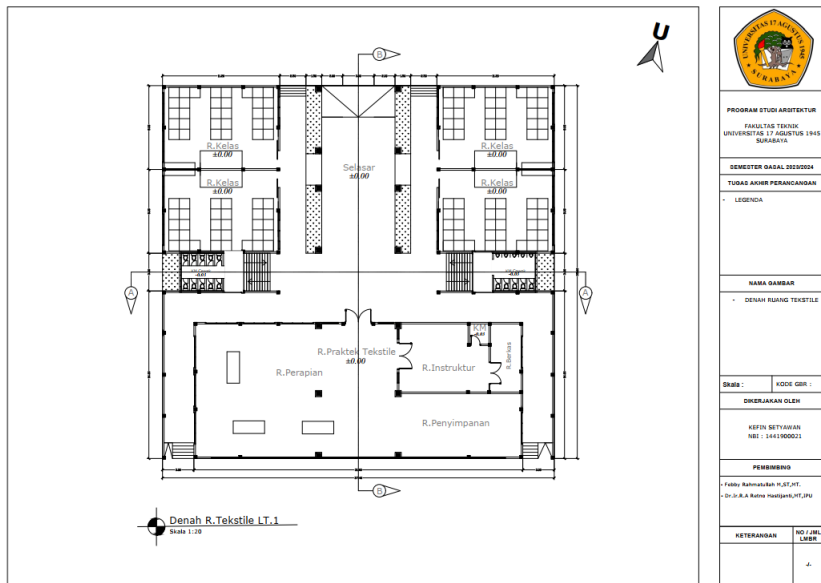

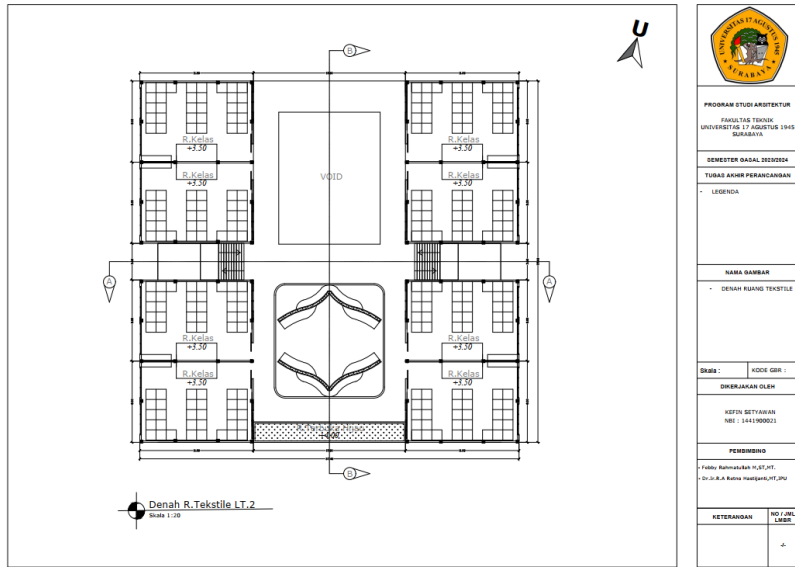

Gambar 6.2.7 Denah Ruang Tekstile

Sumber : Penulis

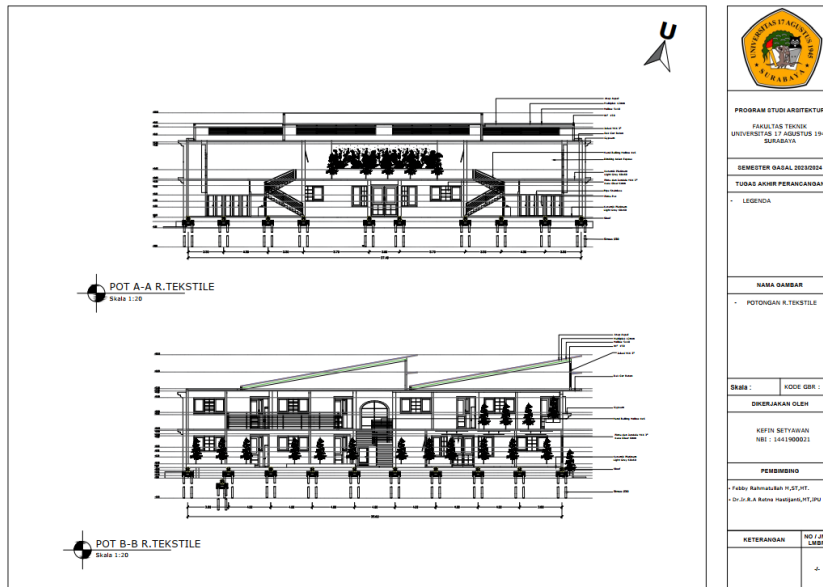

Gambar 6.2.8 Potongan Ruang Tekstile

Sumber : Penulis



PROGRAM STUDI ARSITEKTUR FAKULTAS TEKNIK UNIVERSITAS 17 AGUSTUS 1945 SURABAYA	
SEMESTER GASAL 2023/2024 TUGAS AKHIR PERANCANGAN	
LEGENDA	
NAMA GAMBAR -TAMPAK RUANG TEKSTILE	
Skala :	KODE GBR :
DIKERJAKAN OLEH	
KEFELI SETYAWAN NIM : 1441900021	
PEMBIMBING	
- Felky Rahmatulloba M,ST,MT - Dr.Jr.A.A Ratno Harjanto,M,PT,PU	
KETERANGAN	NO./JML. LEMBAR
	1/1



PROGRAM STUDI ARSITEKTUR FAKULTAS TEKNIK UNIVERSITAS 17 AGUSTUS 1945 SURABAYA	
SEMESTER GASAL 2023/2024 TUGAS AKHIR PERANCANGAN	
LEGENDA	
NAMA GAMBAR -TAMPAK RUANG TEKSTILE	
Skala :	KODE GBR :
DIKERJAKAN OLEH	
KEFELI SETYAWAN NIM : 1441900021	
PEMBIMBING	
- Felky Rahmatulloba M,ST,MT - Dr.Jr.A.A Ratno Harjanto,M,PT,PU	
KETERANGAN	NO./JML. LEMBAR
	1/1

Gambar 6.2.9 Tampak Ruang Tekstile
Sumber : Penulis

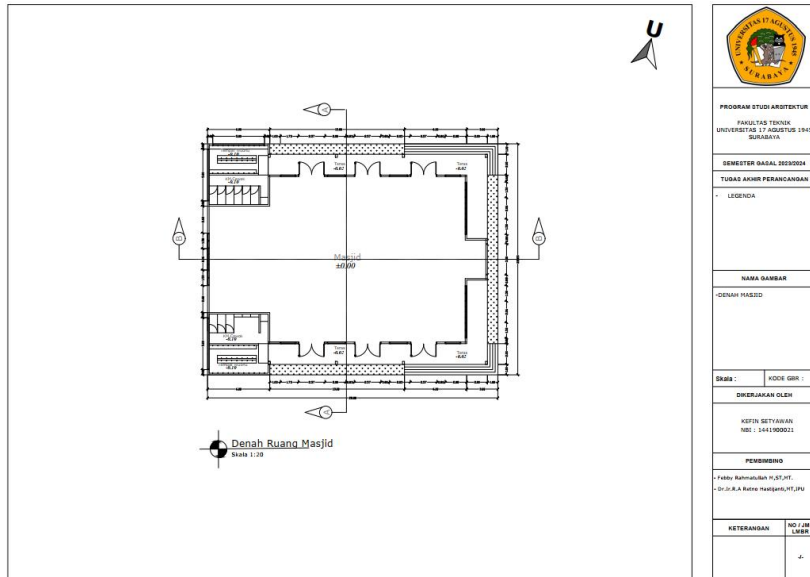

Gambar 6.2.10 Denah Masjid

Sumber : Penulis

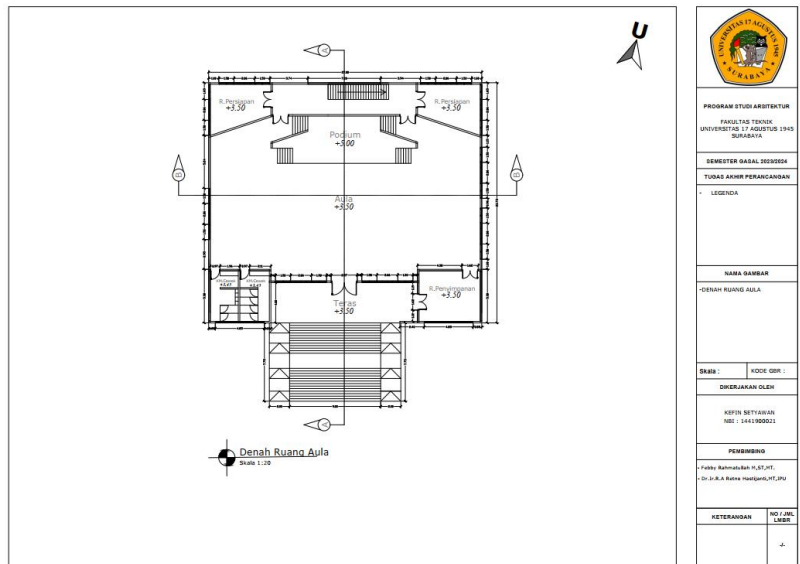

Gambar 6.2.11 Denah Aula

Sumber : Penulis

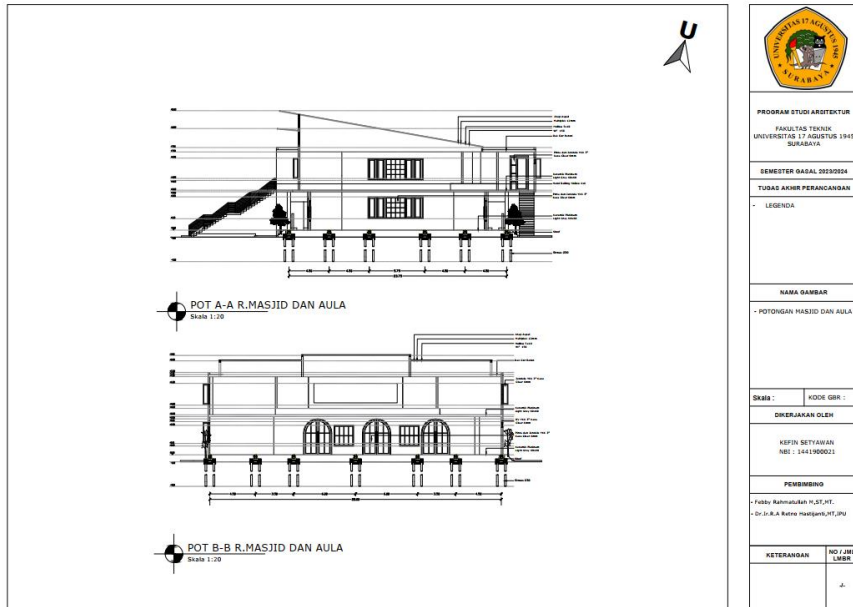

	
PROGRAM STUDI ARSITEKTUR FAKULTAS TEKNIK UNIVERSITAS 17 AGUSTUS 1945 SURABAYA	
SEMESTER GASAL 2023/2024 TUGAS AKHIR PERANCANGAN	
LEGENDA	
NAMA GAMBAR - POTONGAN MASJID DAN AULA	
Skala :	Kode GBR :
Dikerjakan oleh KEVIN SETYAWAN NBI : 1441900021	
PEMBIMBING - Fobby Rahmulyah P.,ST.,PT. - Dr. D.K.A. Ratri Hoesliani,MT,PU	
Keterangan	No / Jml Lembr. - / -

Gambar 6.2.12 Potongan Masjid dan Aula

Sumber : Penulis



	
PROGRAM STUDI ARSITEKTUR FAKULTAS TEKNIK UNIVERSITAS 17 AGUSTUS 1945 SURABAYA	
SEMESTER GASAL 2023/2024 TUGAS AKHIR PERANCANGAN	
LEGENDA	
NAMA GAMBAR -TAMPAK MASJID DAN AULA	
Skala :	Kode GBR :
Dikerjakan oleh KEVIN SETYAWAN NBI : 1441900021	
PEMBIMBING - Fobby Rahmulyah P.,ST.,PT. - Dr. D.K.A. Ratri Hoesliani,MT,PU	
Keterangan	No / Jml Lembr. - / -



Gambar 6.2.13 Tampak Masjid dan Aula

Sumber : Penulis

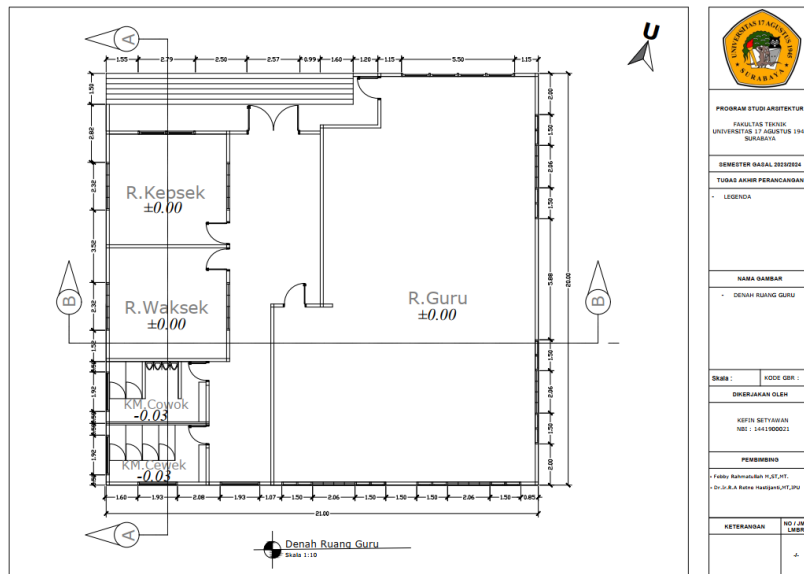

Gambar 6.2.14 Denah Ruang Guru

Sumber : Penulis

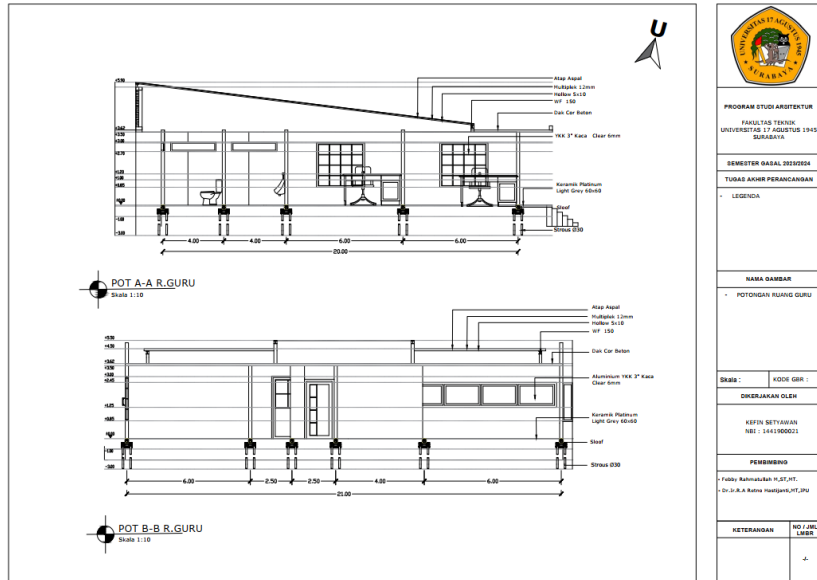

Gambar 6.2.15 Potongan Ruang Guru

Sumber : Penulis





Gambar 6.2.16 Tampak Ruang Guru

Sumber : Penulis

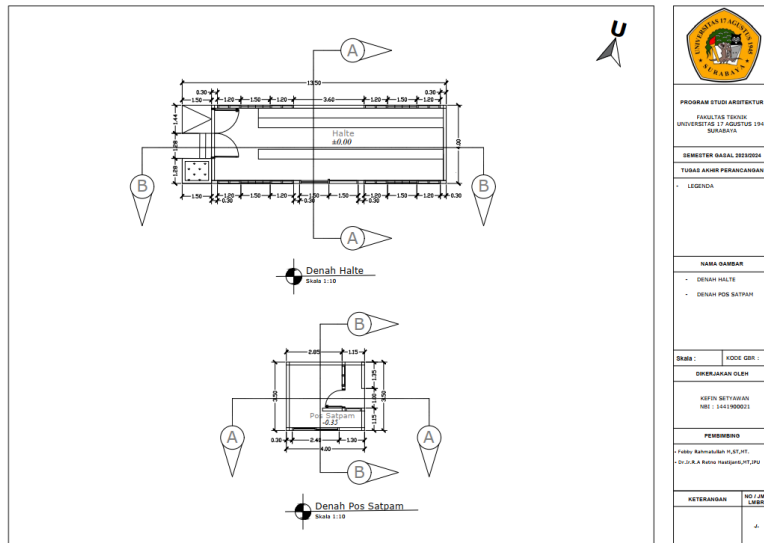

Gambar 6.2.17 Denah Halte dan Pos Satpam

Sumber : Penulis

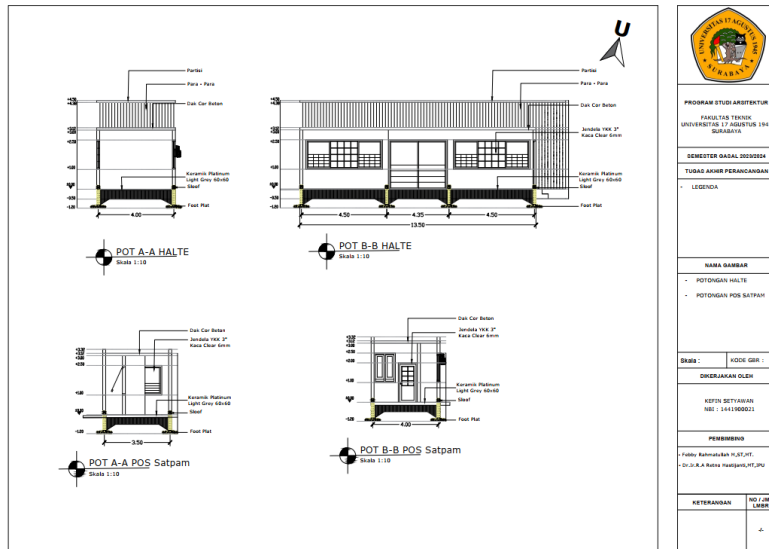

Gambar 6.2.18 Potongan Halte dan Pos Satpam

Sumber : Penulis

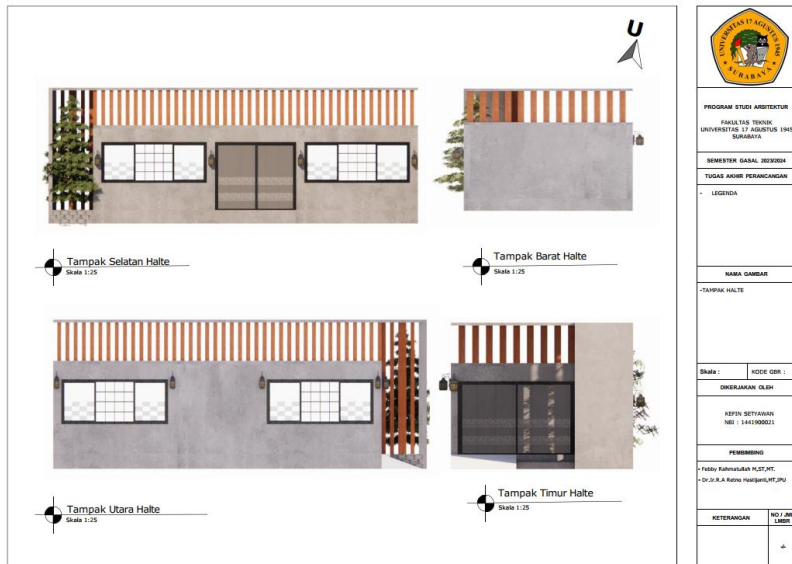

Gambar 6.2.19 Tampak Halte

Sumber : Penulis



Gambar 6.2.20 Tampak Halte

Sumber : Penulis

	
PROGRAM STUDI ARSITEKTUR FAKULTAS TEKNIK UNIVERSITAS 17 AGUSTUS 1945 SURABAYA	
SEMESTER GASAL 2023/2024	
TUGAS AKHIR PERANCANGAN	
LEGENDA	
NAMA GAMBAR	
TAMPIL POS SATPAM	
Skala :	KODE GBR :
DIBERIKAN OLEH	
KEFIRI SETYANAN NIM : 1441900021	
PEMBIMBING	
+ Fidyia Rahmatulohid NLET_MIT + Dr. Ir. A. A. Rania-Hastipurni MPT, PU	
KETERANGAN	NO. / JML. LEMBR
	-/-

6.3 Sistem Struktur dan Utilitas

Konsep struktur bangunan menggunakan Pondasi Strouss dengan lebar sloff 30x30, Kolom 30x30 dan Balok 30x40

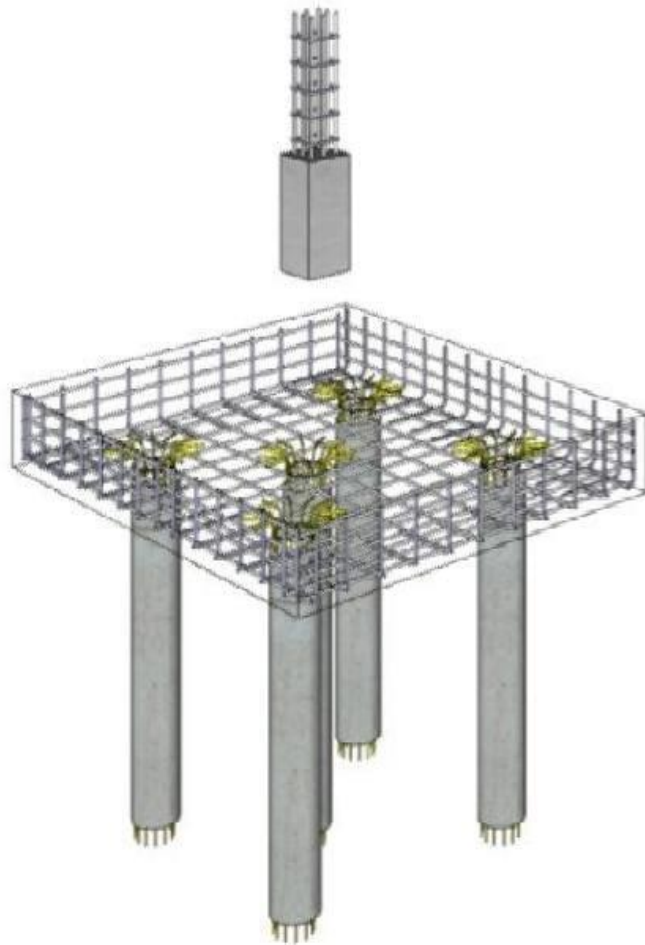

Gambar 6.3.1 Struktur Bangunan

Utilitas .

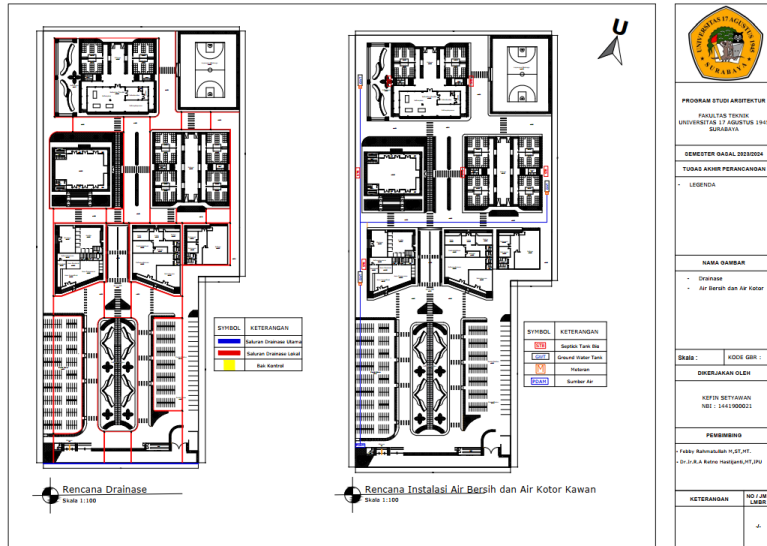

Gambar 6.3.2 Rencana Drainase Air Bersih dan Air Kotor

Sumber : Penulis

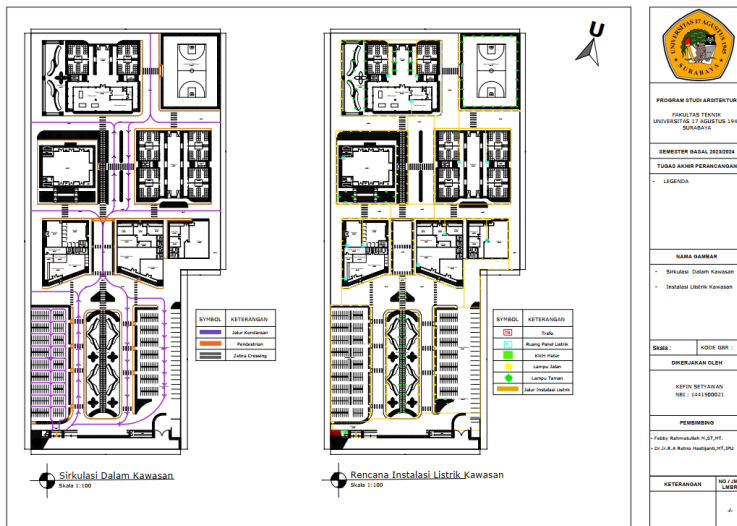

Gambar 6.3.3 Rencan Sirkulasi dan Instalasi Listrik

Sumber : Penuli

6.4 Perspektif dan Detail



Gambar 6.4.1 Perspektif Gedung Utama

Sumber : Penulis



Gambar 6.4.2 Perspektif Gedung Fashion

Sumber : Penulis



	
PROGRAM STUDI ARSITEKTUR FAKULTAS TEKNIK UNIVERSITAS 17 AGUSTUS 1945 SURABAYA	
SEMESTER GASAL 2023/2024 TUGAS AKHIR PERANCANGAN	
- LEGENDA	
NAMA GAMBAR	
-PERSPEKTIF RUANG GURU	
PERSEKUTU	
Skala :	KODE GBR :
DIBERIKAN OLEH	
KEFIN SETYAWAN NBI : 1441900021	
PEMBIBING	
-Febby Rahmawati NKT,MT -Dr. Dr. R. A. Rinto Harjanti, MT, PU	
KETERANGAN	NO. J. AM. LABEL
	1

Gambar 6.4.5 Perspektif Gedung Guru

Sumber : Penulis



	
PROGRAM STUDI ARSITEKTUR FAKULTAS TEKNIK UNIVERSITAS 17 AGUSTUS 1945 SURABAYA	
SEMESTER GASAL 2023/2024 TUGAS AKHIR PERANCANGAN	
- LEGENDA	
NAMA GAMBAR	
PERSPEKTIF HALTE	
PERSEKUTU	
Skala :	KODE GBR :
DIBERIKAN OLEH	
KEFIN SETYAWAN NBI : 1441900021	
PEMBIBING	
-Febby Rahmawati NKT,MT -Dr. Dr. R. A. Rinto Harjanti, MT, PU	
KETERANGAN	NO. J. AM. LABEL
	1

Gambar 6.4.6 Perspektif Halte

Sumber : Penulis



	
PROGRAM STUDI ARCHITECTUR FAKULTAS TEKNIK UNIVERSITAS 17 AGUSTUS 1945 SURABAYA	
SEMESTER GABAL 2020/2021 TUGAS AKHIR PERANCANGAN	
LEGENDA	
NAMA GAMBAR PERSPEKTIF POS SATPAM	
Skala :	KODE GSK :
DIBERIKAN OLEH KEFIR SETYAWAN NRI : 1441908021	
PEMBimbing - Pesty Rahmawatiyah M,ST,MT - Dr. Dr. R. A. Retno Hoesni,MT,PTU	
KETERANGAN	NO. JML. LEMBAR
	4

Gambar 6.4.7 Perspektif Pos Satpam

Sumber : Penulis



	
PROGRAM STUDI ARCHITECTUR FAKULTAS TEKNIK UNIVERSITAS 17 AGUSTUS 1945 SURABAYA	
SEMESTER GABAL 2020/2021 TUGAS AKHIR PERANCANGAN	
LEGENDA	
NAMA GAMBAR PERSPEKTIF SPOT LUAR	
Skala :	KODE GSK :
DIBERIKAN OLEH KEFIR SETYAWAN NRI : 1441908021	
PEMBimbing - Pesty Rahmawatiyah M,ST,MT - Dr. Dr. R. A. Retno Hoesni,MT,PTU	
KETERANGAN	NO. JML. LEMBAR
	4

Gambar 6.4.8 Perspektif Spot Luar

Sumber : Penulis



Gambar 6.4.9 Perspektif Siang dan Malam Gedung Tekstile

Sumber : Penulis



Gambar 6.4.10 Perspektif Siang dan Malam Gedung Fashion

Sumber : Penulis



Gambar 6.4.11 Perspektif Siang dan Malam Masjid dan Aula

Sumber : Penulis

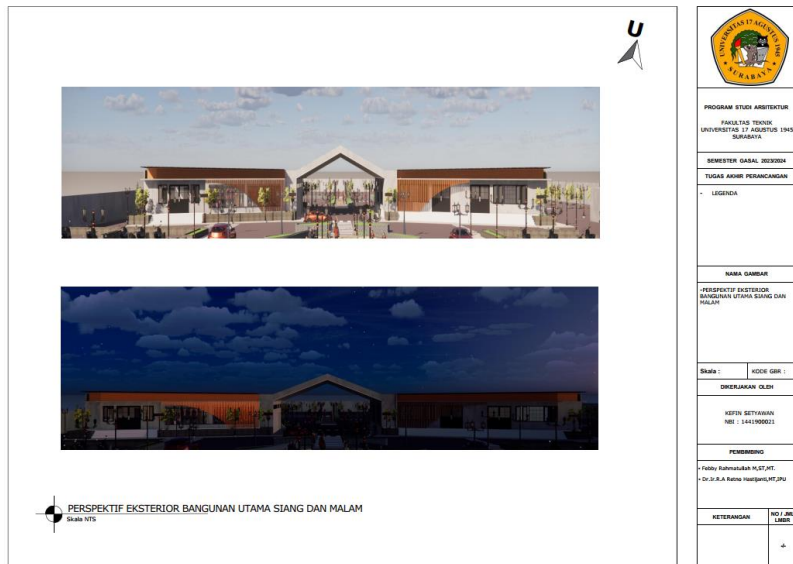

Gambar 6.4.12 Perspektif Siang dan Malam Masjid dan Aula

Sumber : Penulis

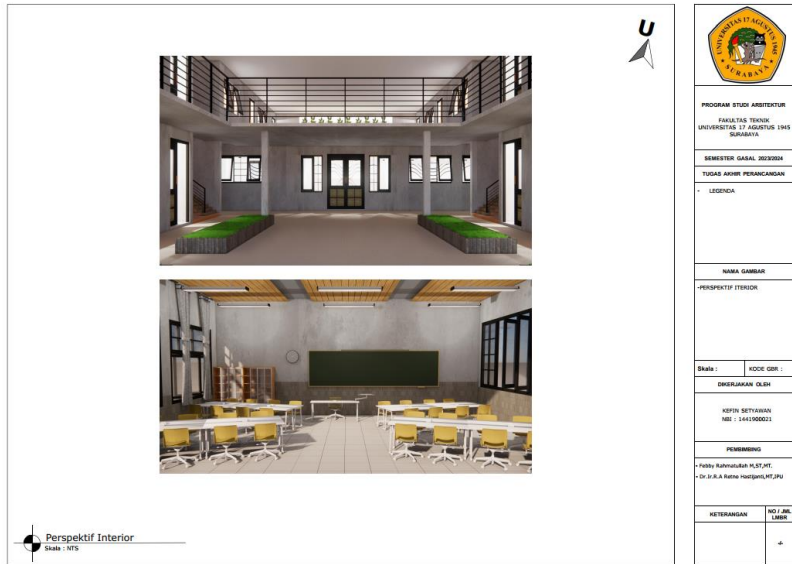

Perspektif Interior
Salam : NTS

	
PROGRAM STUDI ARSITEKTUR FAKULTAS TEKNIK UNIVERSITAS 17 AGUSTUS 1945 SURABAYA	
SEMESTER GASAL 2023/2024 TUGAS AKHIR PERANCANGAN	
LEGENDA	
NAMA GAMBAR PERSPEKTIF INTERIOR	
Skala :	KODE GBR :
DIMERJAKAN OLEH	
KEFIRI SETYAWAN NBI : 1641900021	
PEMERISNG	
Fakhri Rahmatullah H, ST, MT Dit. D. A. A. Raha Hasdipah, MT, PU	
KETERANGAN	NO / JML LEMBAR
	1 / 1

Gambar 6.4.13 Perspektif Interior

Sumber : Penulis

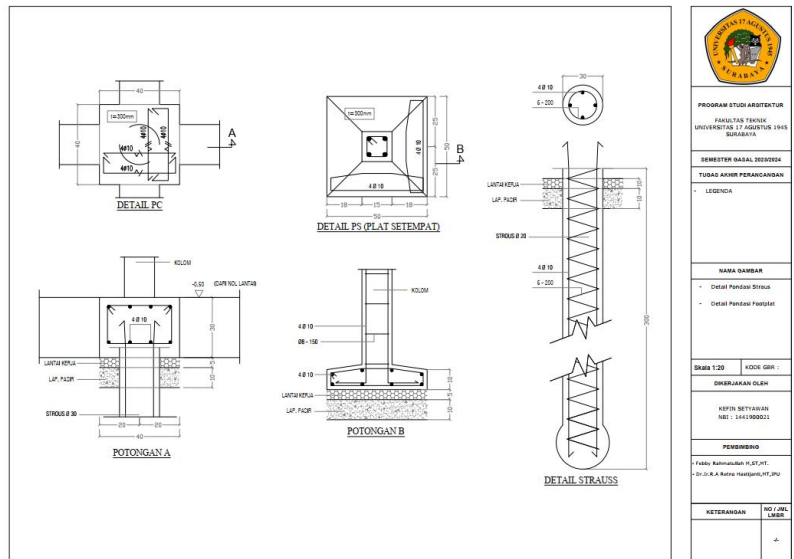

	
PROGRAM STUDI ARSITEKTUR FAKULTAS TEKNIK UNIVERSITAS 17 AGUSTUS 1945 SURABAYA	
SEMESTER GASAL 2023/2024 TUGAS AKHIR PERANCANGAN	
LEGENDA	
NAMA GAMBAR - Detail Pondasi Strouss - Detail Pondasi Potongan	
Skala 1:20	KODE GBR :
DIMERJAKAN OLEH	
KEFIRI SETYAWAN NBI : 1641900021	
PEMERISNG	
Fakhri Rahmatullah H, ST, MT Dit. D. A. A. Raha Hasdipah, MT, PU	
KETERANGAN	NO / JML LEMBAR
	1 / 1

Gambar 6.4.14 Detail Pondasi

Sumber : Penulis

6.5 Maket



Gambar 6.5.1 Maket

Sumber : Penulis

DAFTAR PUSTAKA

- Chalista., Rakha Alief., Rahman, Avirur., Widjajanto, Danu. 2021. *Industri*. Link: <https://id.wikipedia.org/w/index.php?title=Industri&action=history>. Diakses 25 November 2022
- Dewamadeteguhsuradipa. 2015. *PENGAPLIKASIAN KONSEP PADA GAMBAR 3D (FINAL)*. Link: <https://1219251044dewamadeteguhsuradipa.wordpress.com/> Diakses 20 Oktober 2022
- Faiq, Nuraini. Parmin. 2021. *Anggaran Pendidikan Lebih dari 20 Persen, APBD Surabaya 2022 Akan Ditetapkan pada 10 November 2021*. Diakses 29 November 2022.
- Hestanto. 2007. *Ekonomi Kreatif*. Link: <https://www.hestanto.web.id/ekonomi-kreatif/>. Diakses 12 Desember 2022.
- Ibnu. 2020. *Pengertian Industri Kreatif dan Contoh Industri Kreatif di Indonesia*. Link: <https://accurate.id/bisnis-ukm/pengertian-industri-kreatif/>. Diakses 28 November 2022.
- Kementrian Riset, Trknologi, dan Pendidikan tinggi (RISTEKDIKTI). 2017. *RENCANA INDUK RISET NASIONAL TAHUN 2017-2045*.
- Munasya. 2016. *MENGUAK POTENSI KOTA SURABAYA DALAM BERBAGAI BIDANG*. Link: <https://munasya.com/potensi-kota-surabaya-dalam-berbagai-bidang/>. Diakses 25 November 2022
- Neman, Alex., Setyawanary., Uzul, Fauzul., Setyawan, Eka Bagus. Herry., Hasan. 2021. *Kota Surabaya*. Link: https://id.wikipedia.org/wiki/Kota_Surabaya. Diakses 24 November 2022.
- Pemerintah Provinsi Jawa Timur. *RENCANA PEMBANGUNAN JANGKA MENENGAH DERAH (RPJMD) PROVINSI JAWA TIMUR TAHUN 2019-2024*.
- Pemerintah Provinsi Jawa Timur. *RENCANA STRATEGIS PENDIDIKAN JAWA TIMUR TAHUN 2019-2024*.
- PT. Asuransi Central Asia. 2018. *5 Ciri Khas Desain Industrial yang Harus Anda Tahu*. Link: <https://www.aca.co.id/Info-Asuransi-Detail/Ciri-Khas-Desain-Industrial>. Diakses 21 Oktober 2022
- Saldyni, Nivita. 2022. *Pemkot Surabaya Buka Pendaftaran FPPS 2022, Khusus Sineas Kota Pahlawan*. Link : <https://www.urbanasia.com/pemkot-surabaya->

buka-pendaftaran-ffps-2022-khusus-sineas-kota-pahlawan-U61981. Diakses 27 November 2022.

Walikota Surabaya Provinsi Jawa Timur. *Peraturan Daerah Kota Surabaya Nomor 12 Tahun 2014 Tentang Rencana TataRuang Wilayah Kota Surabaya Tahun 2014-2034.*