

## LAMPIRAN

### Lampiran 1 Proses Desain Alat



## Lampiran 2 Pembuatan Rangka



**Lampiran 3 Pemasangan Kontrol Box**



**Lampiran 4 Hasil Perakitan**



**Lampiran 5 Uji Coba**

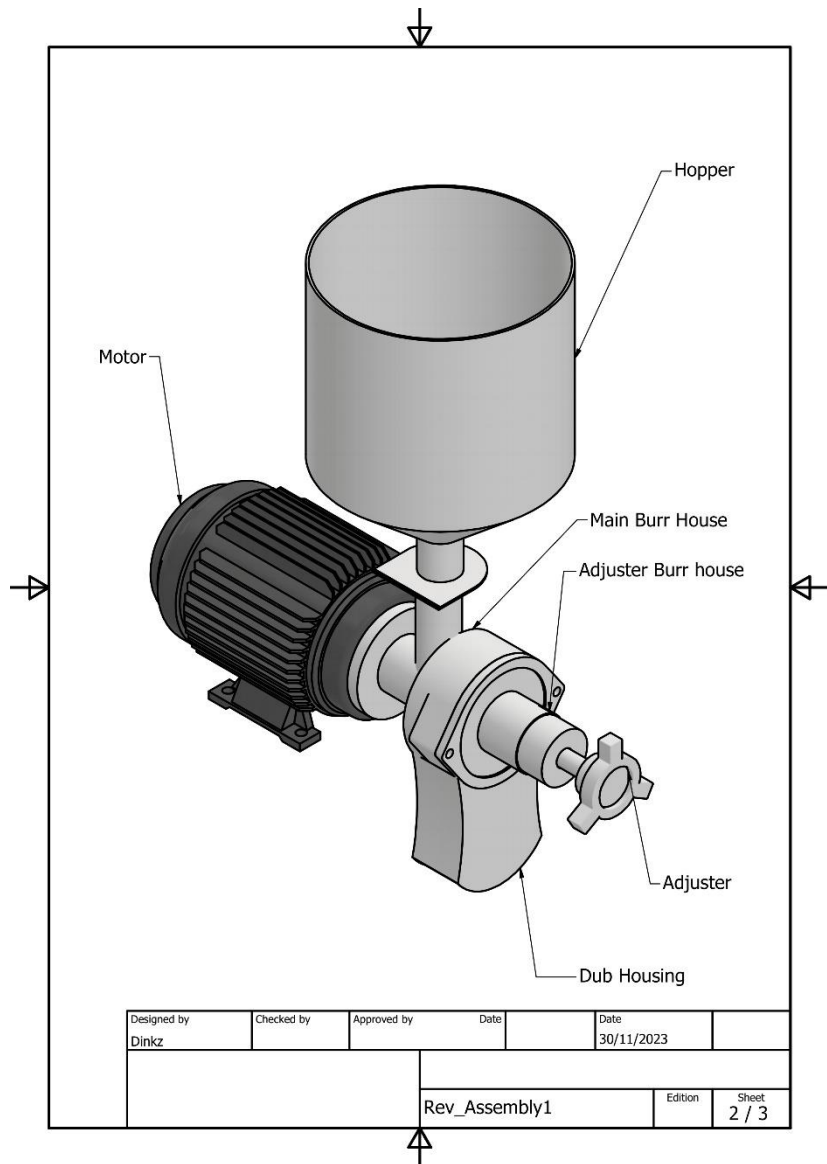

**Lampiran 6 Gambar Teknik Permesinan Luar**

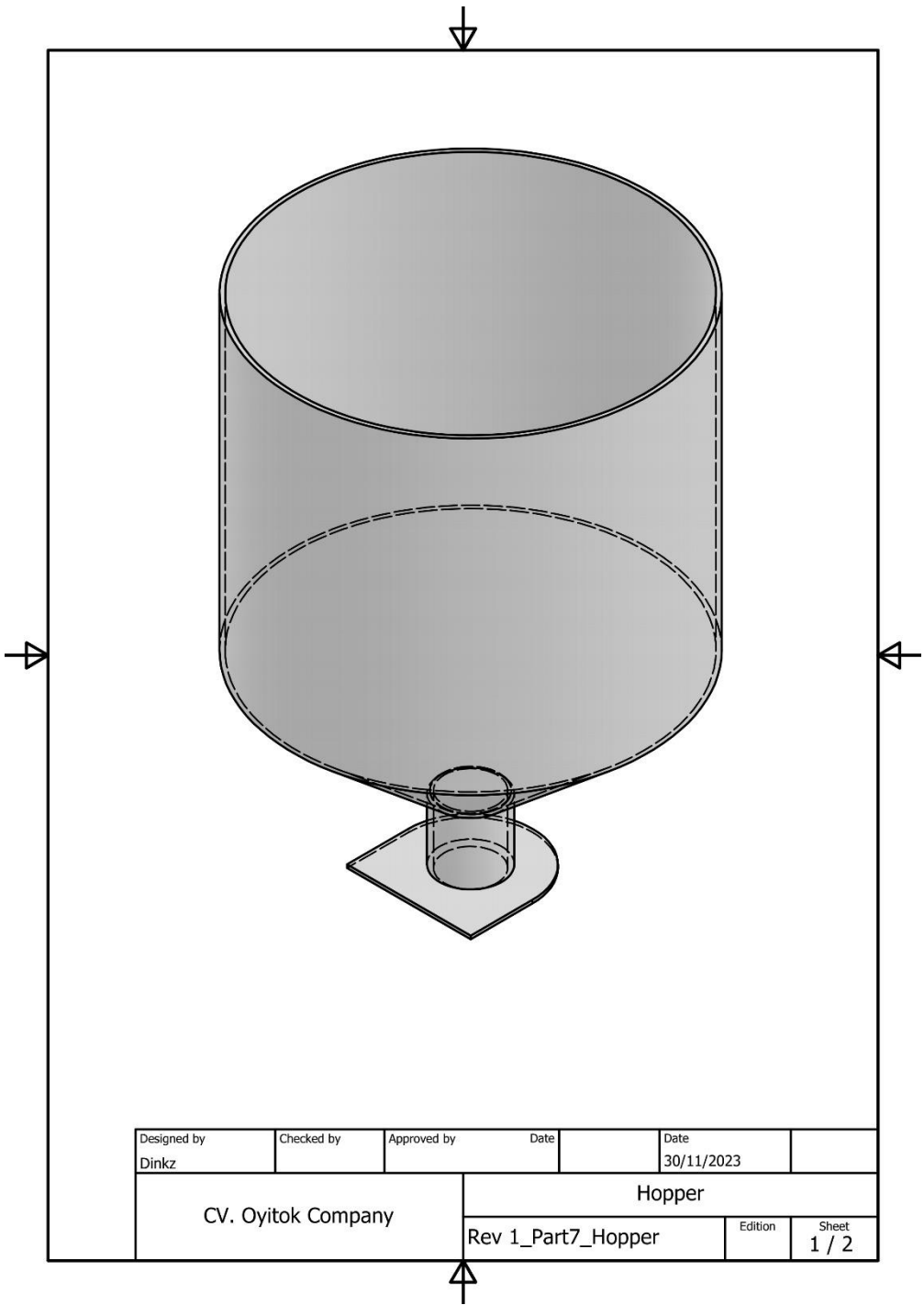

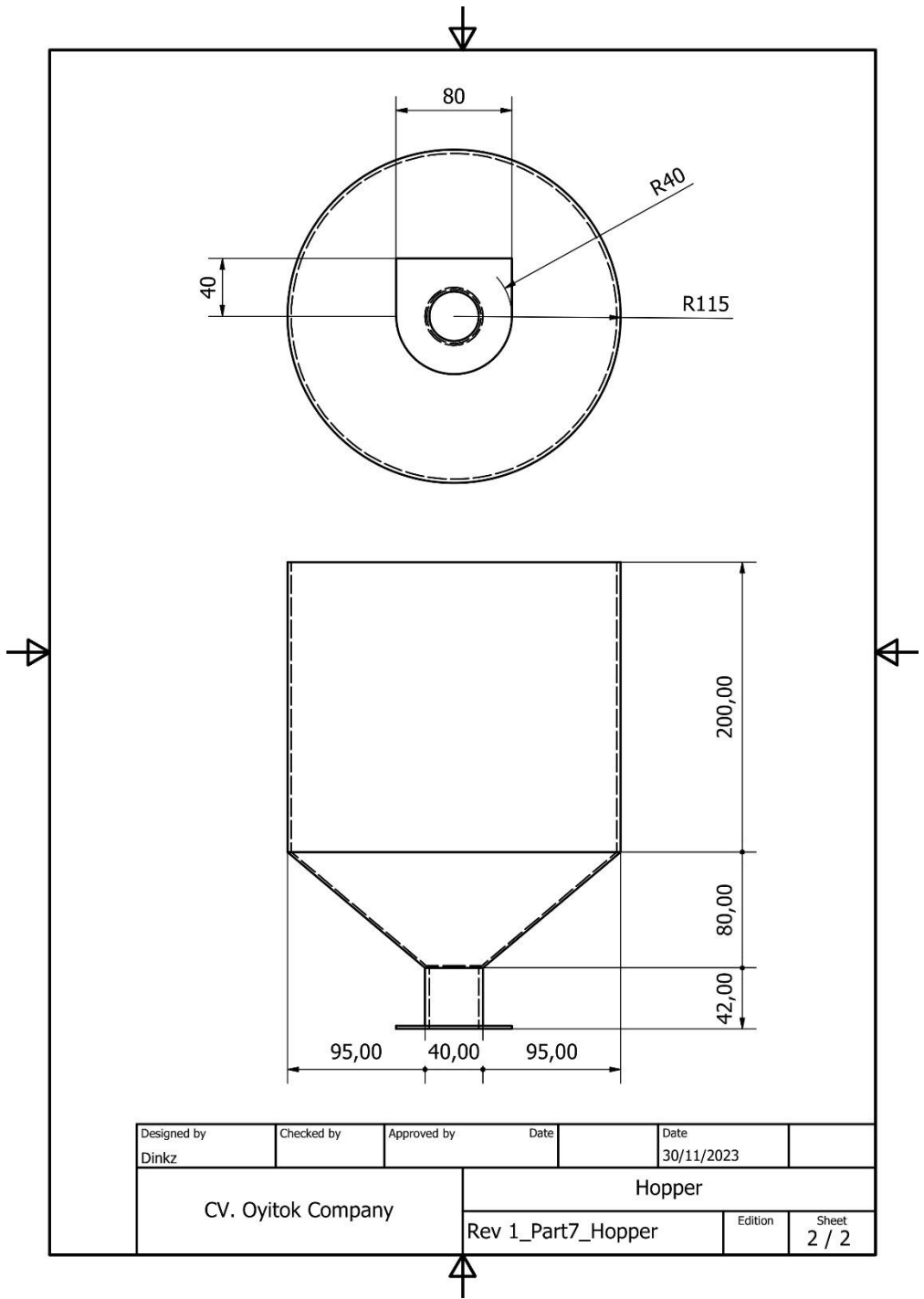

Designed by Dinkz	Checked by	Approved by	Date	Date 30/11/2023	
CV. Oytok Company			Hopper		
Rev 1_Part7_Hopper			Edition	Sheet 2 / 2	



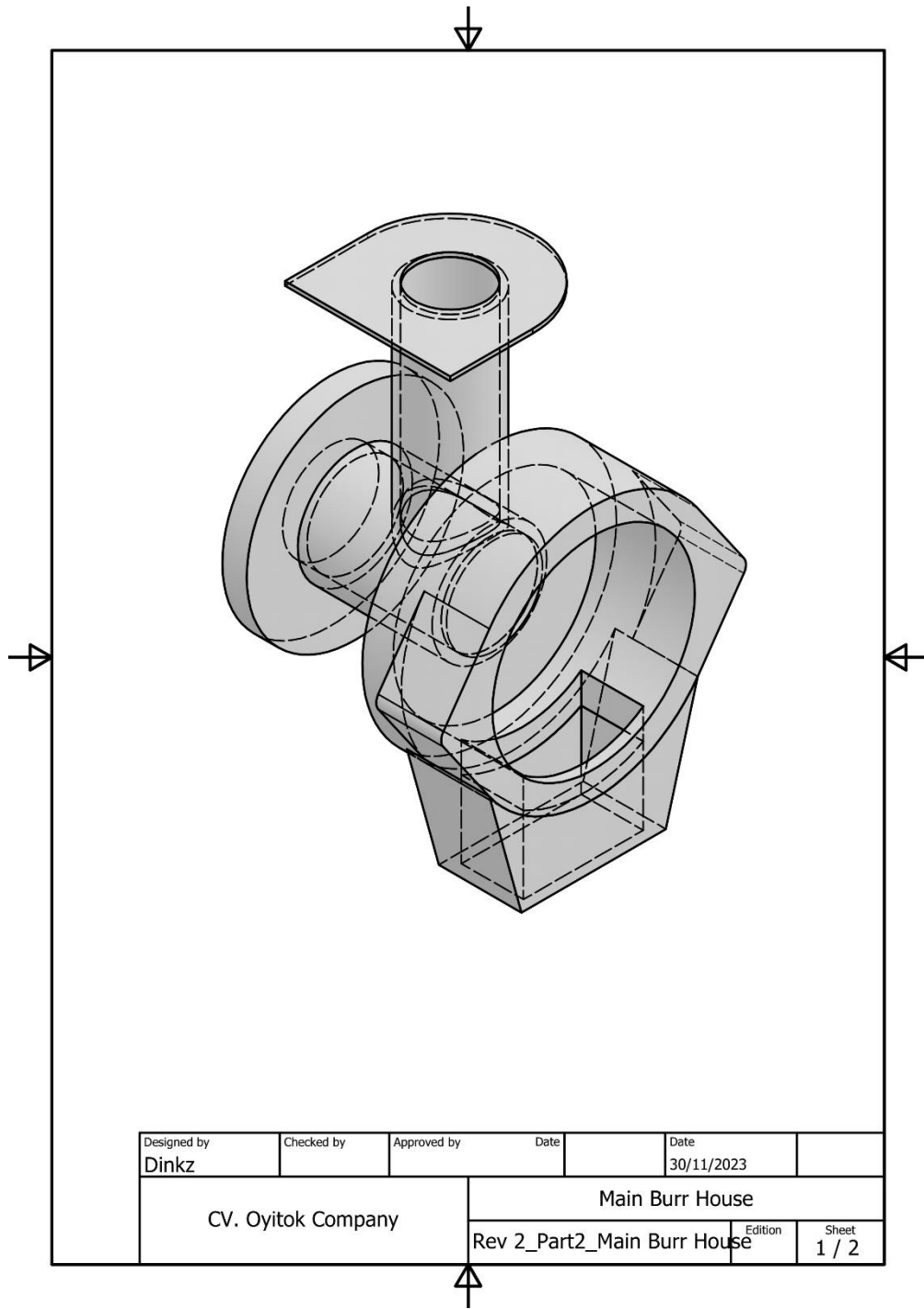

Designed by Dinkz	Checked by	Approved by	Date	Date 30/11/2023	
CV. Oyitok Company			Main Burr House		
			Rev 2_Part2_Main Burr House	Edition	Sheet 1 / 2

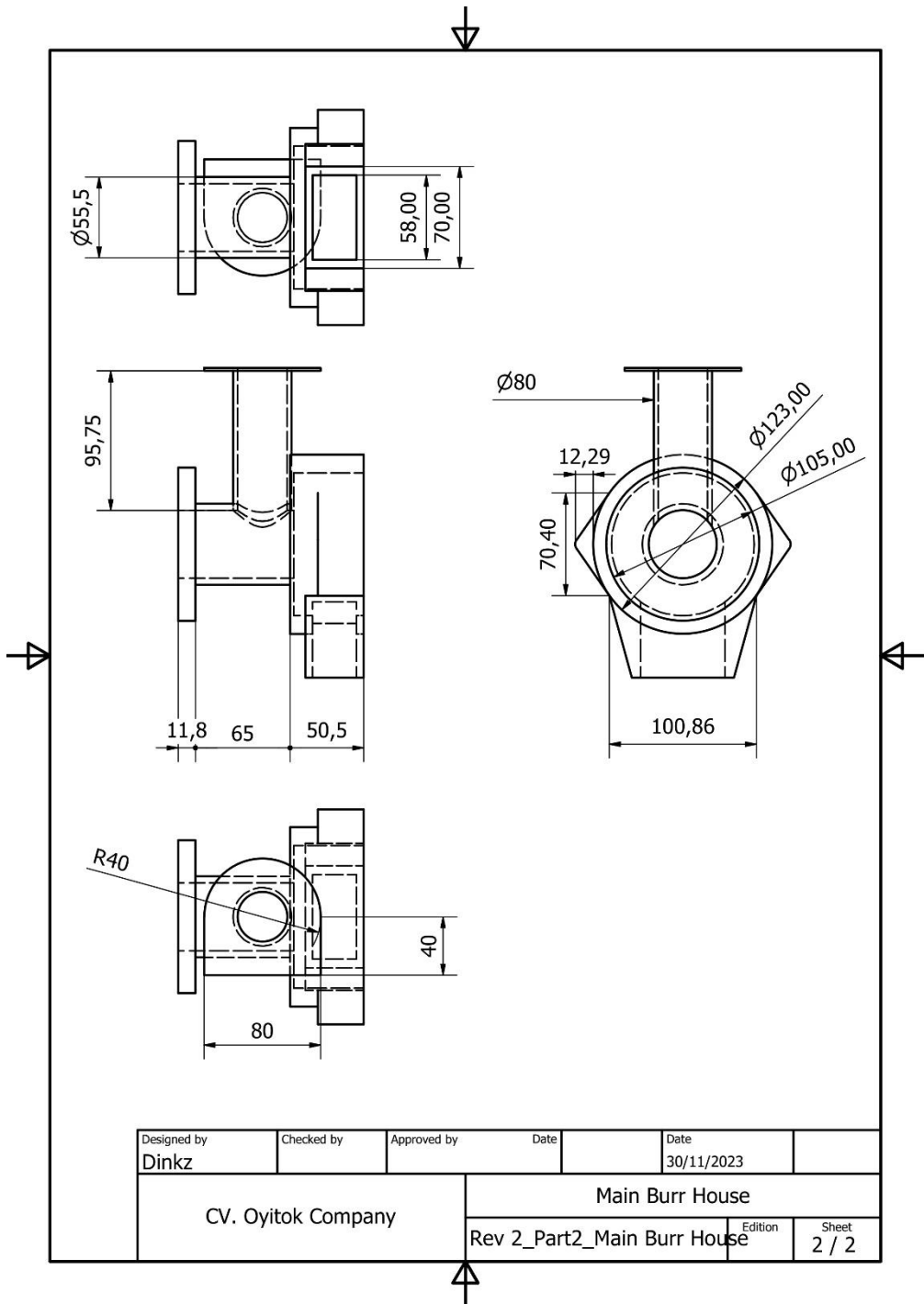

Designed by Dinkz	Checked by	Approved by	Date	Date 30/11/2023	
CV. Oyitok Company			Main Burr House		
Rev 2_Part2_Main Burr House			Edition	Sheet 2 / 2	

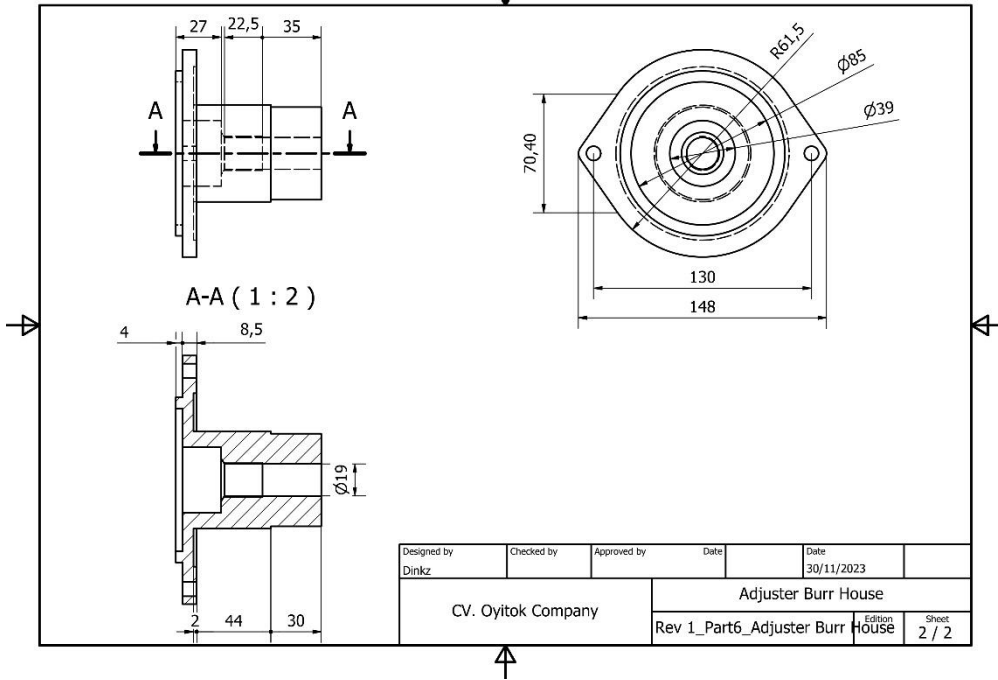
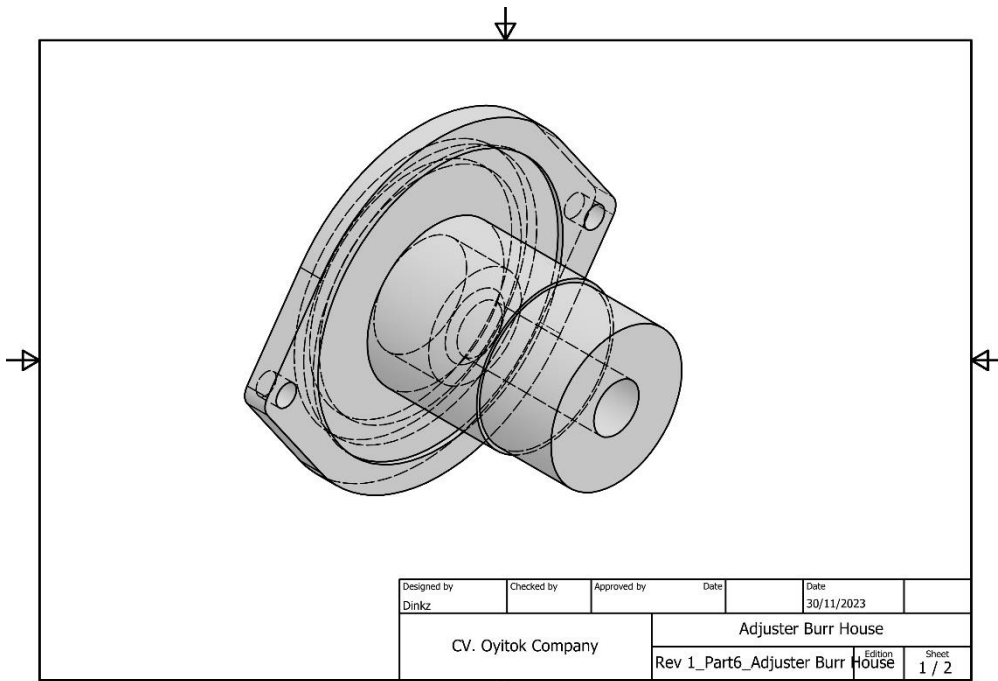

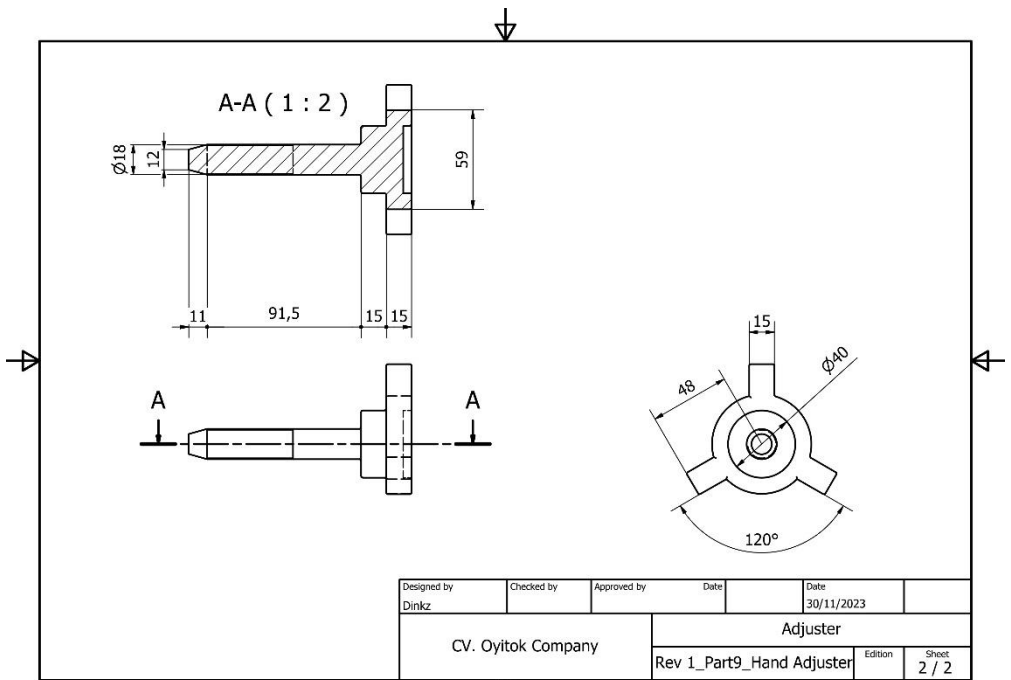
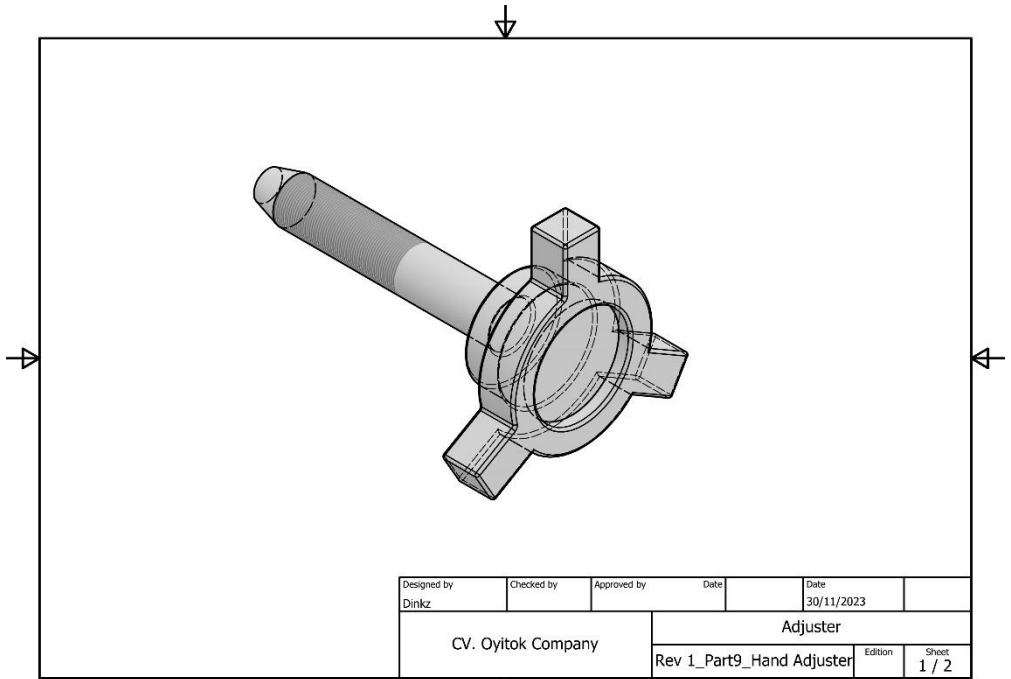

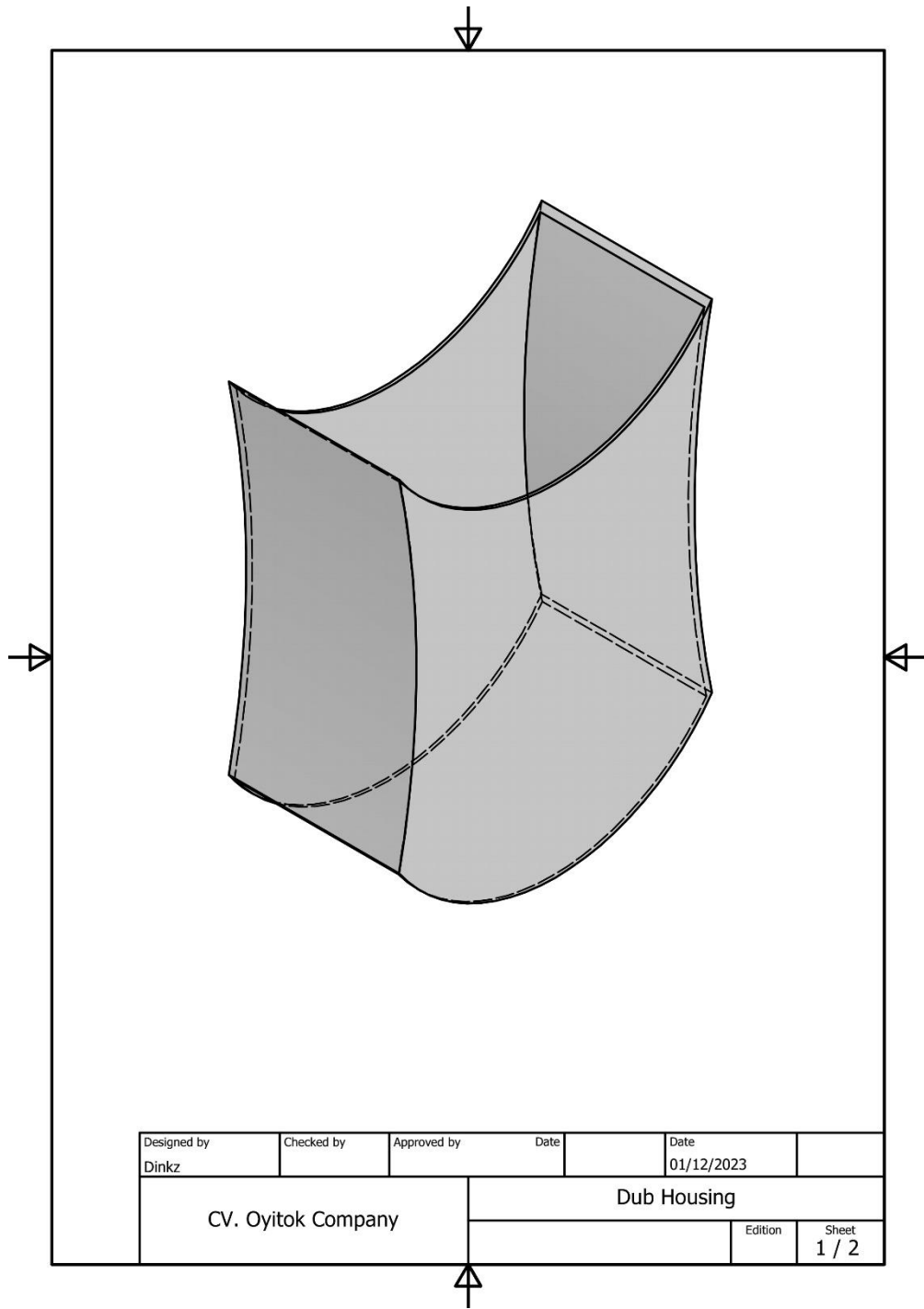

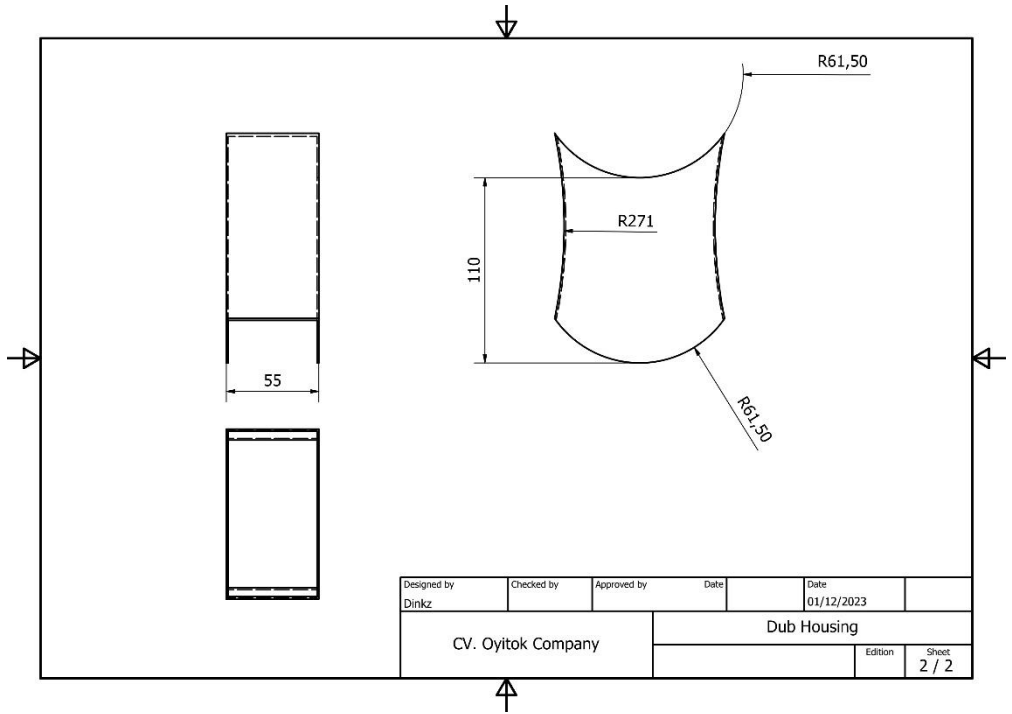

**Lampiran 7 Gambar Teknik Permesinan Dalam**

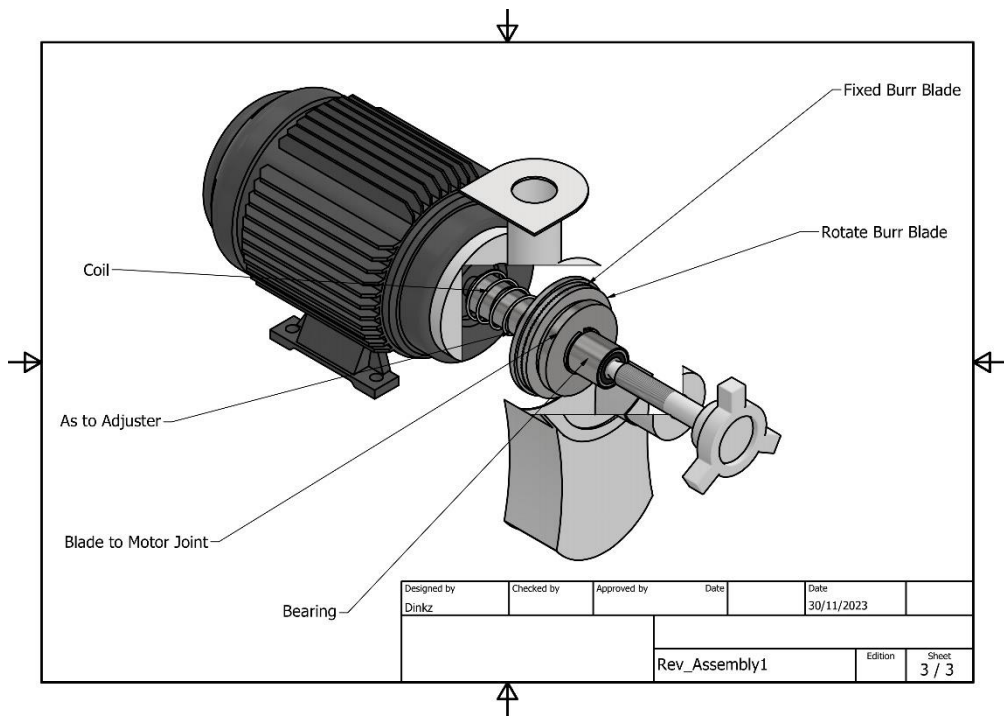

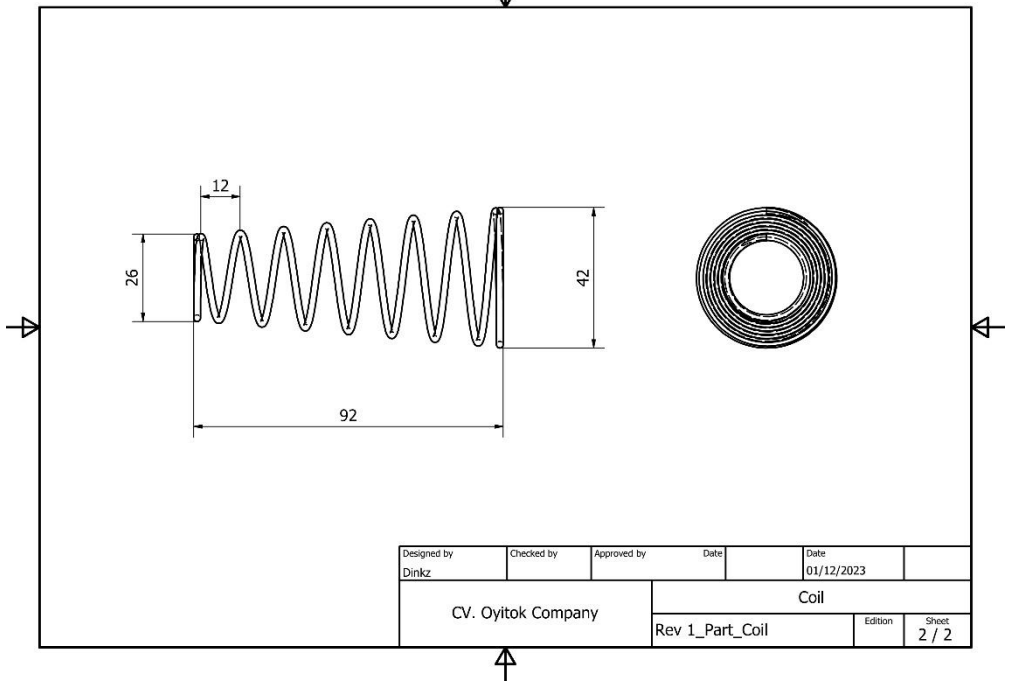
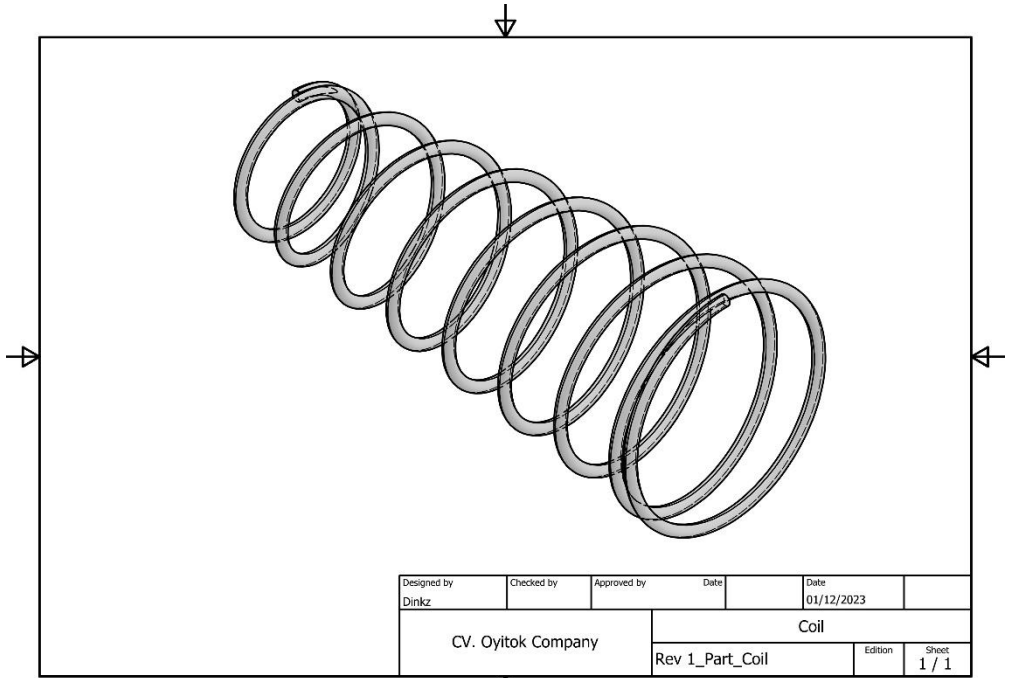



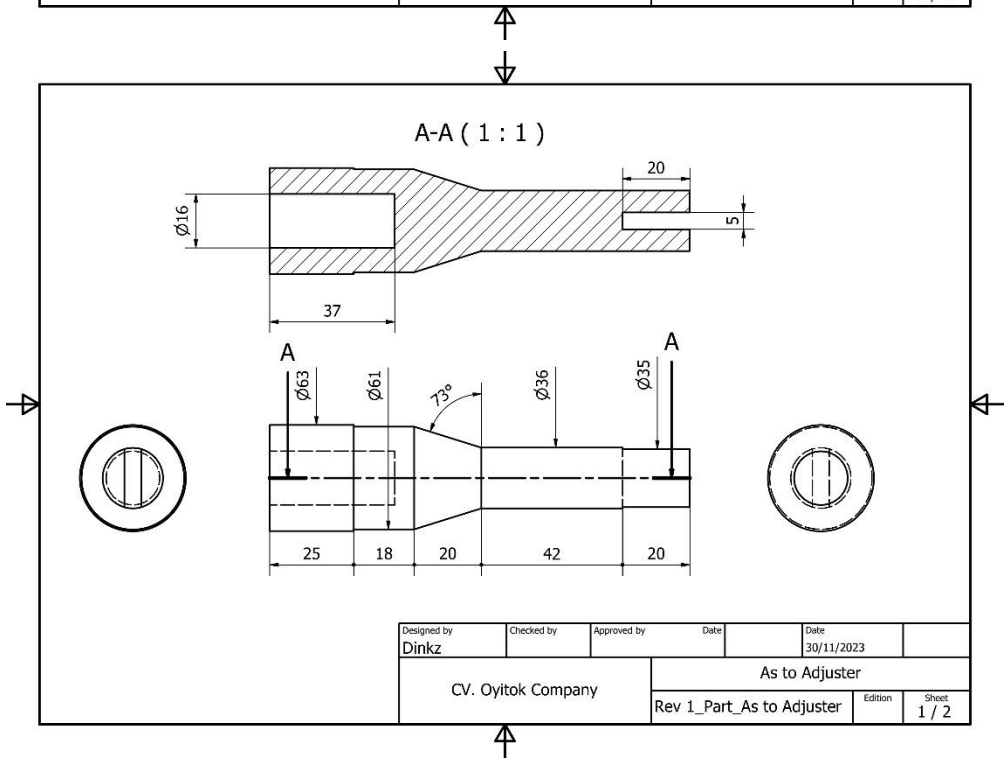
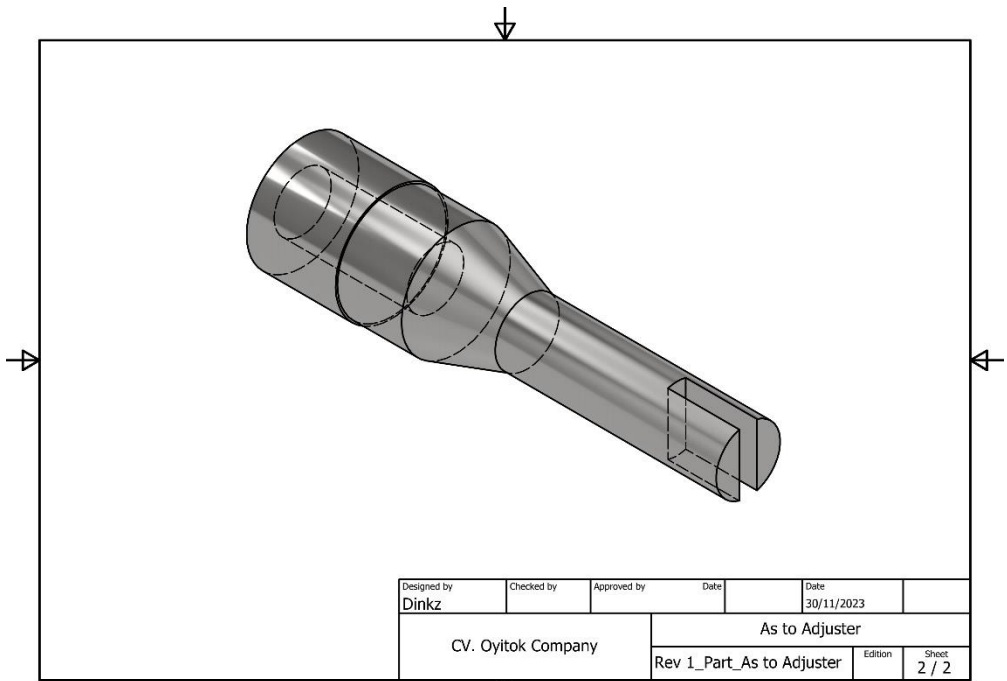

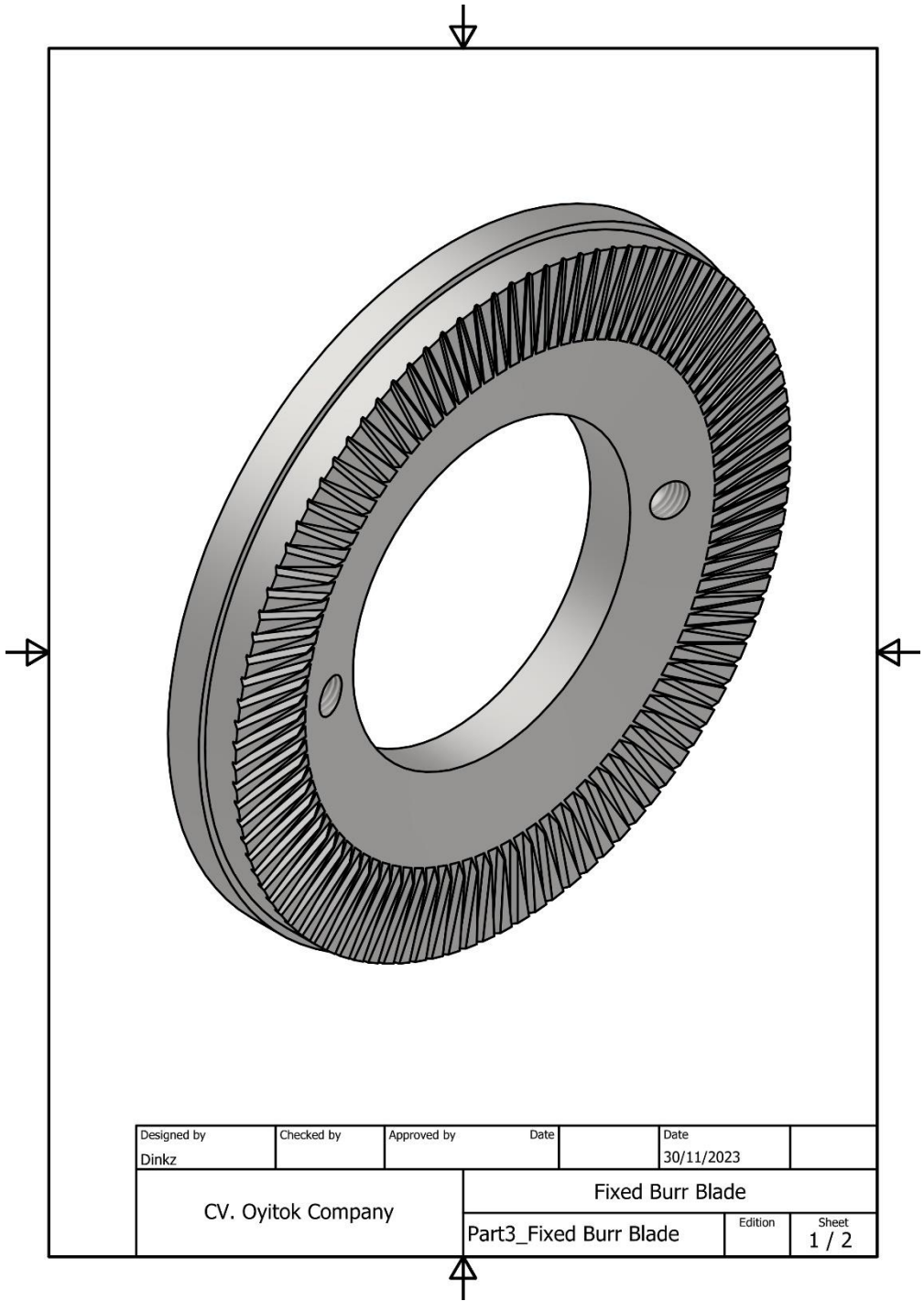

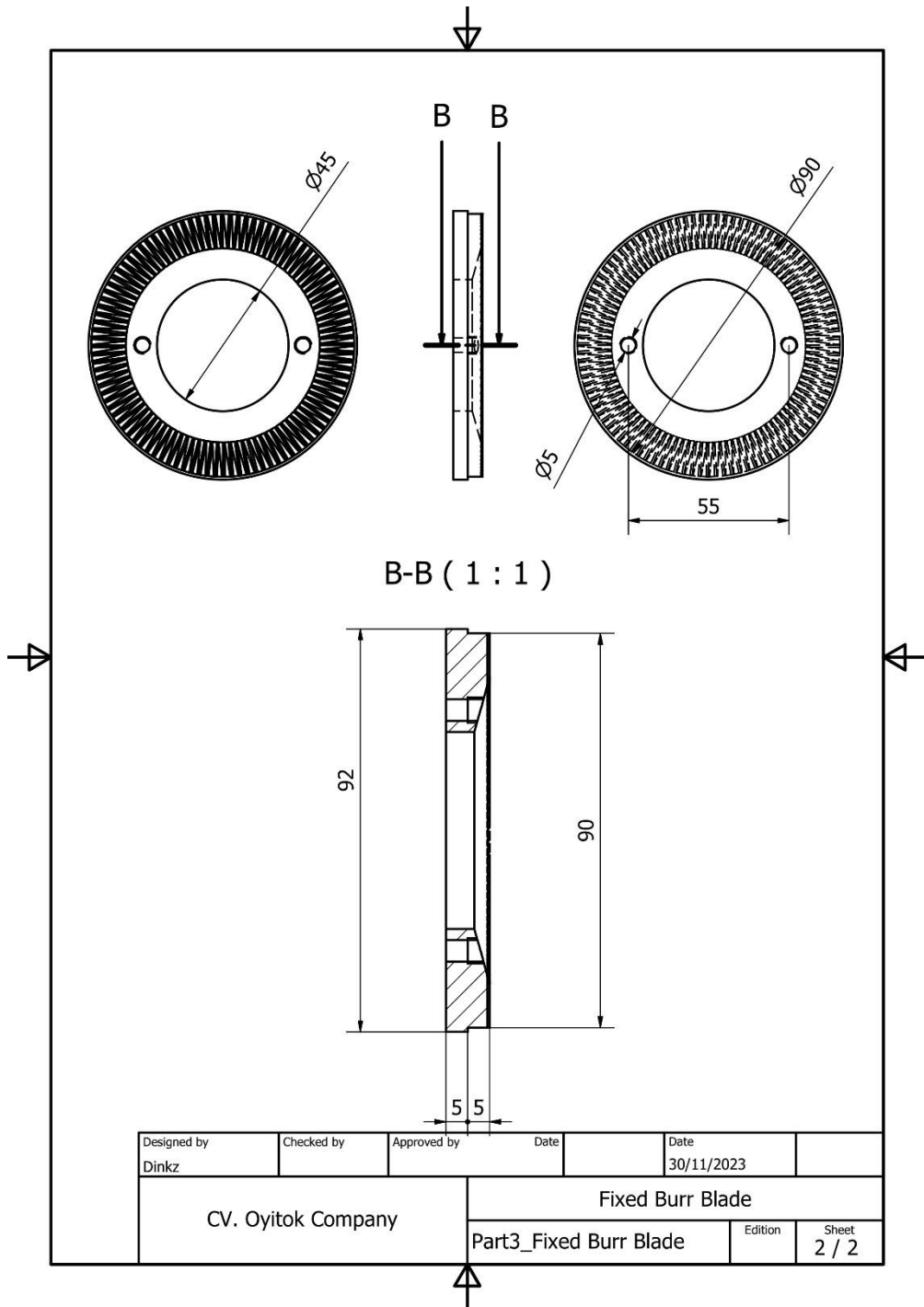

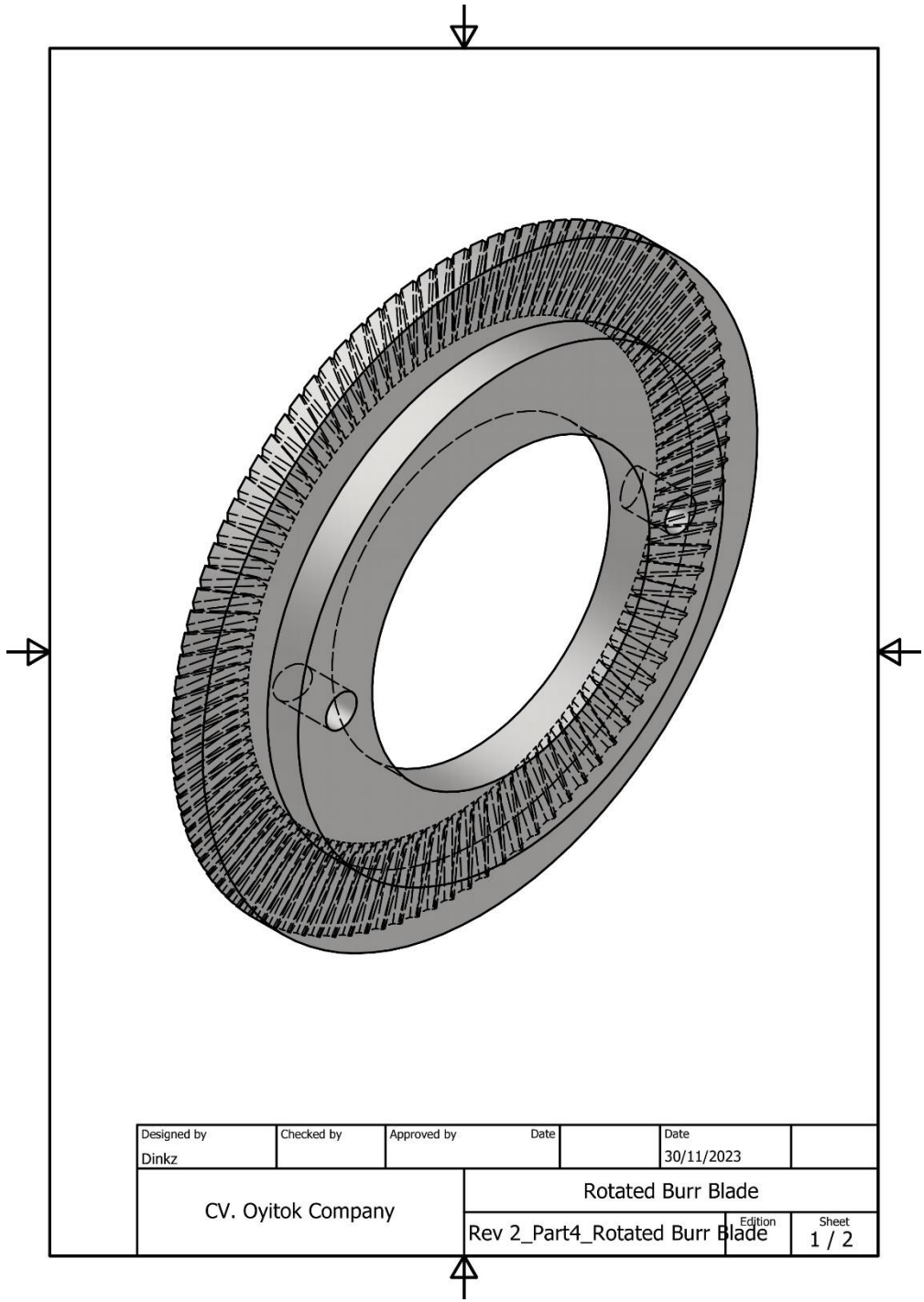

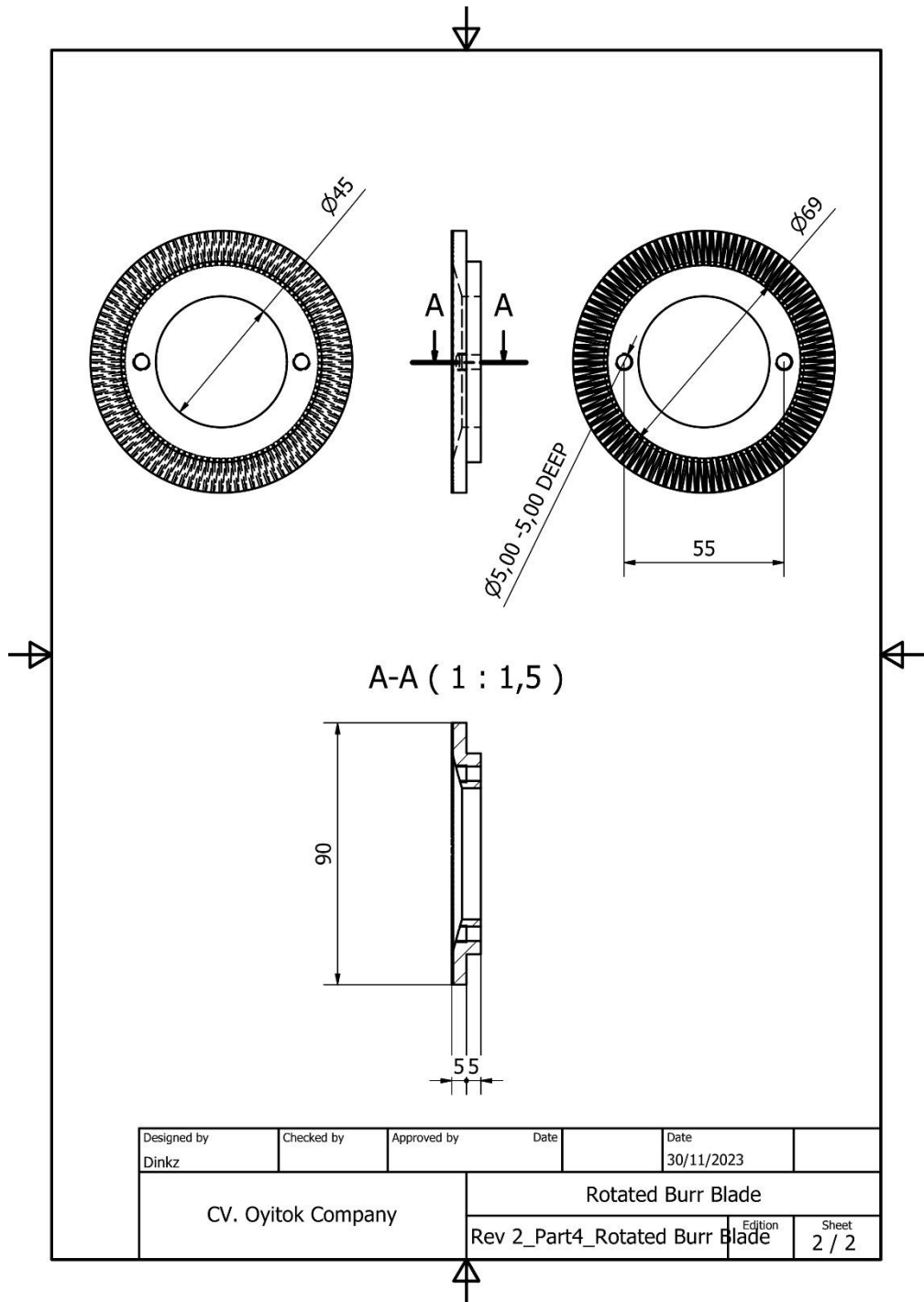

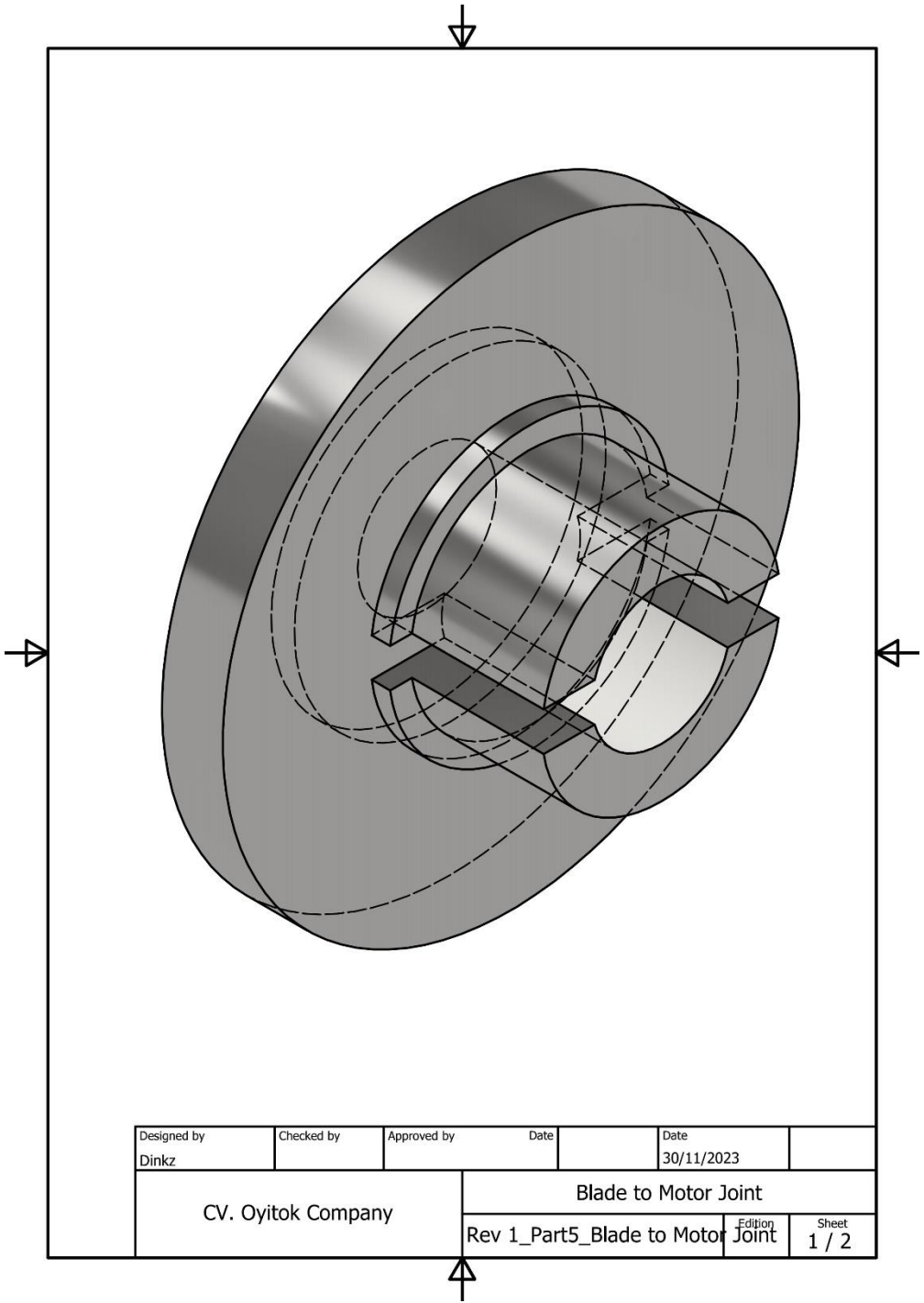

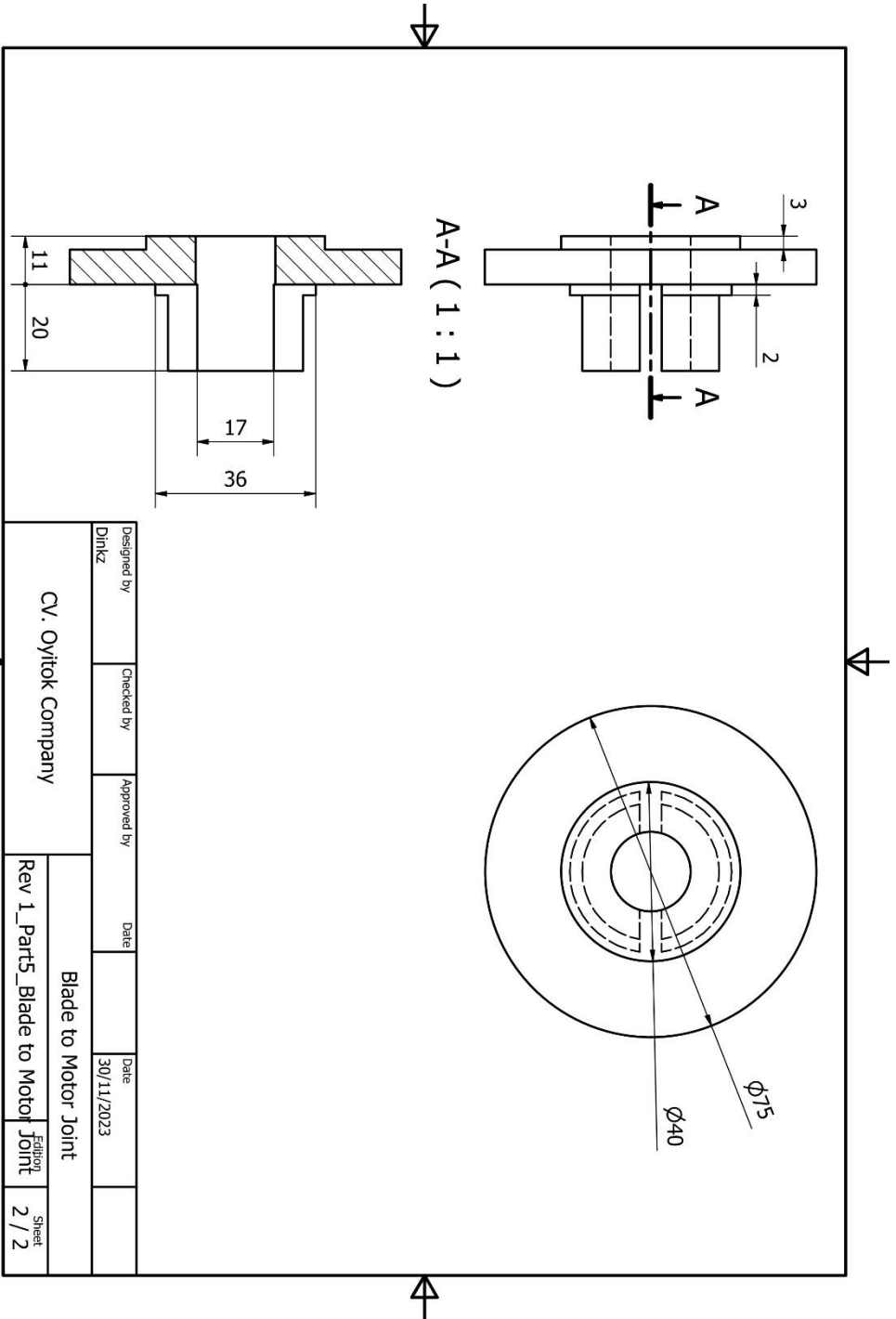

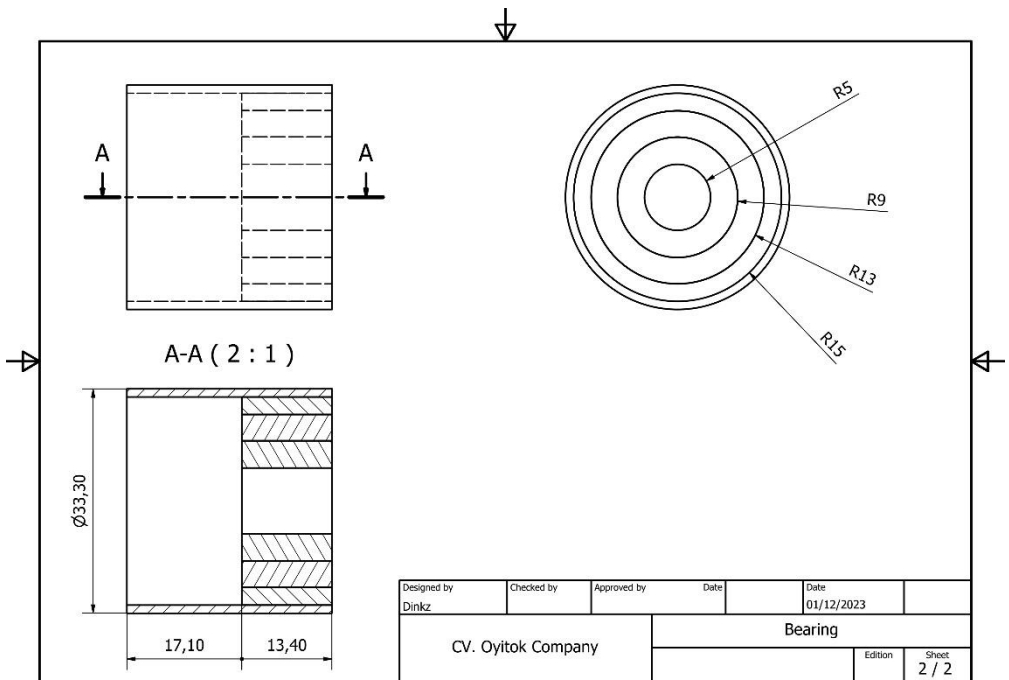
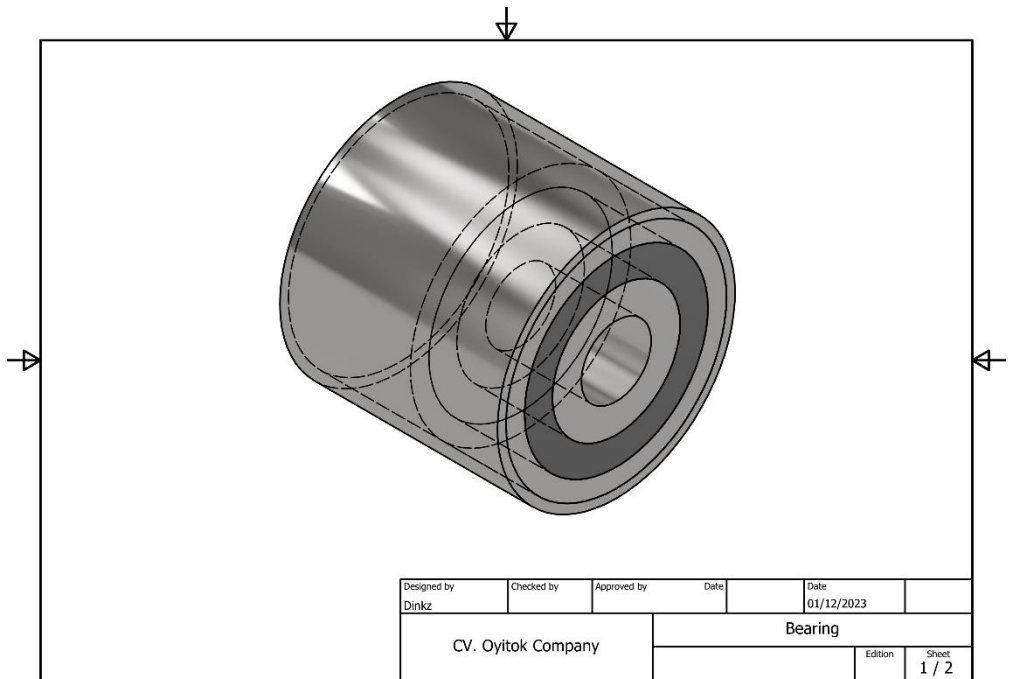



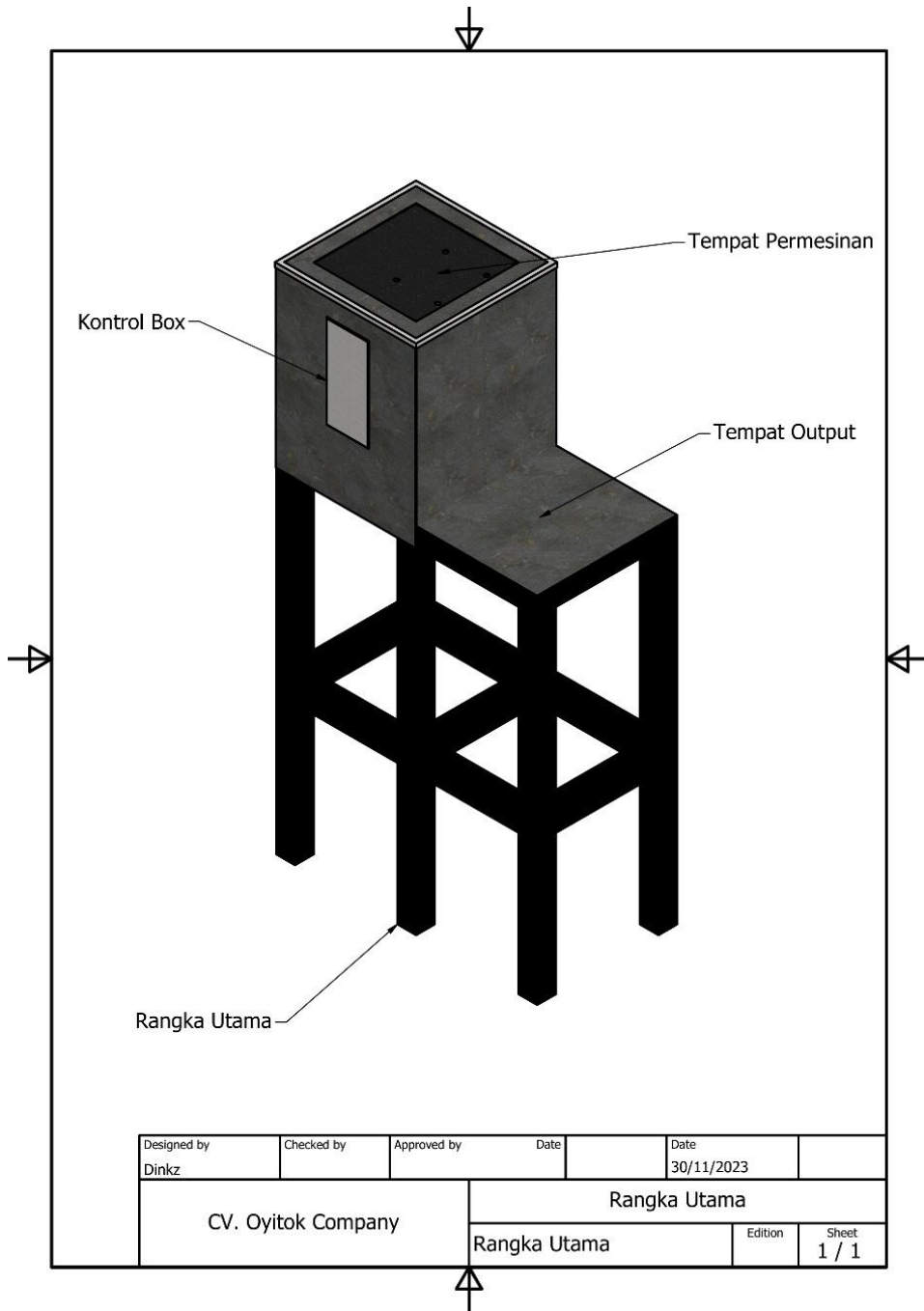

Lampiran 8 Gambar Teknik Rangka

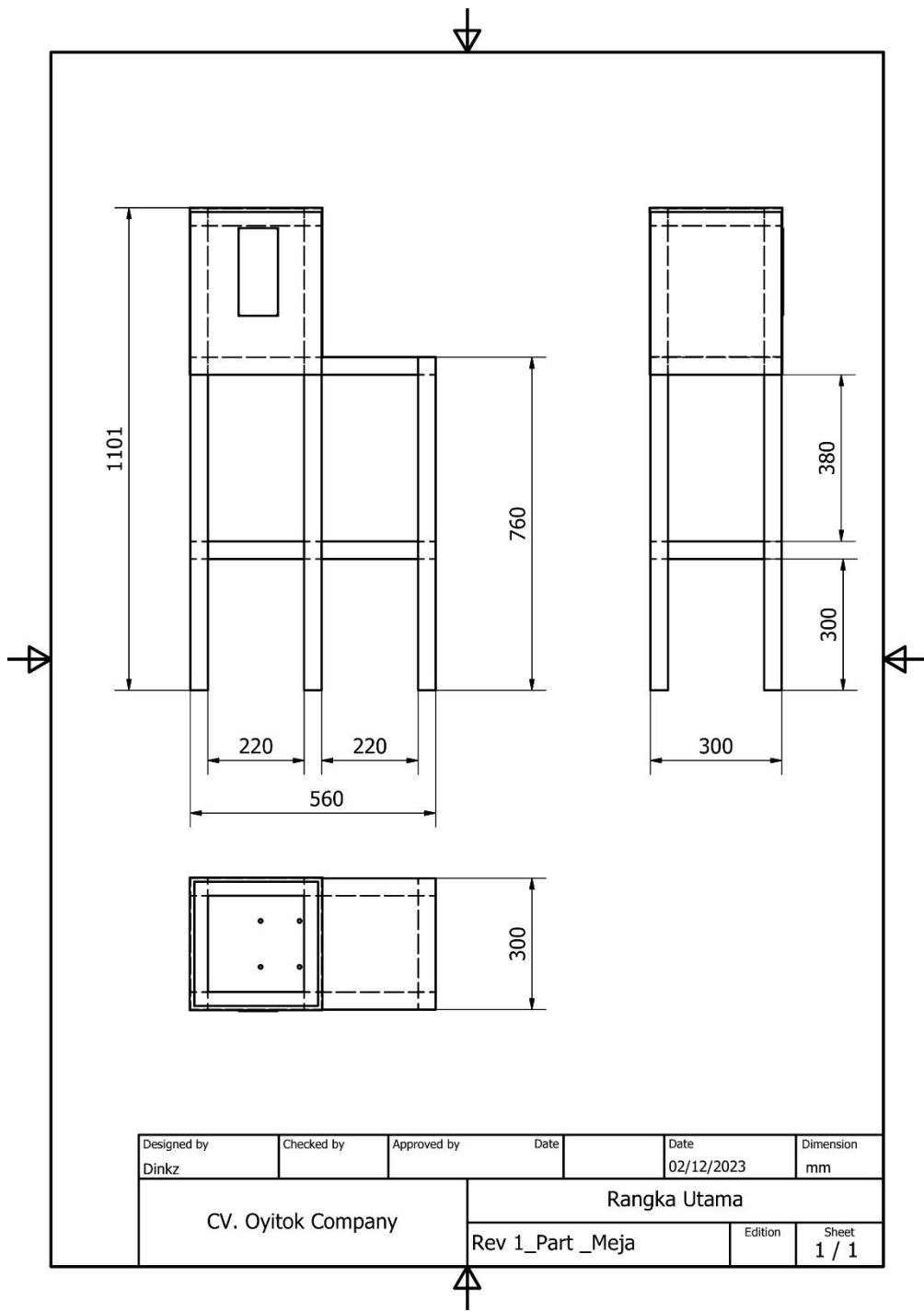



Designed by Dinkz	Checked by	Approved by	Date	Date 02/12/2023	Dimension mm
CV. Oyitok Company			Rangka Utama		
Rev 1_Part_Meja				Edition	Sheet 1 / 1

## Lampiran 9 Surat Izin Penelitian



**UNIVERSITAS 17 AGUSTUS 1945 (UNTAG) SURABAYA**  
**FAKULTAS TEKNIK**

Kampus : Jl. Semolowaru No. 45 Surabaya 60118 Telp. +62 31 5931800 (hunting) Fax, +62 31 5927817

- Program Studi Teknik Industri
- Program Studi Teknik Elektro
- Program Studi Teknik Mesin
- Program Studi Teknik Informatika
- Program Studi Teknik Sipil
- Program Studi Sistem dan Teknologi Informasi
- Program Studi Arsitektur
- Program Studi Magister Teknik Sipil

Homepage : ft.untag-sby.ac.id      Email : teknik@untag-sby.ac.id

---

Nomor : **1087/K/FT/Akd/VI/2023** Surabaya, 27 Juni 2023  
Lampiran : -  
Perihal : **Penelitian Tugas Akhir**

Kepada Yth : **UMKM Oyitok Coffee**  
**Sudimoro Karajan RT. 04 Kec. Bululawang Kab. Malang**

Dengan hormat,

Sebagai salah satu persyaratan untuk menyelesaikan studi pada program Strata 1, maka mahasiswa/mahasiswi diwajibkan untuk melakukan **Penelitian Tugas Akhir** sebagai penerapan teori dan praktek yang diperoleh selama masa studinya.

Sehubungan dengan hal tersebut, maka dengan ini kami mohon Bapak/Ibu berkenan untuk memberikan ijin kepada mahasiswa/mahasiswi sebagai berikut :

No	Nama	NBI	EMAIL	No.HP
1.	M. Dzaky Arraffi	1411900057	dzaky.arraffi@gmail.com	089682239299
2.	Abid Nurkhourudin	1411900153		

Program Studi Teknik Industri  
Guna melaksanakan **Penelitian Tugas Akhir** di :

**"UMKM Oyitok Coffee"**

yang akan dimulai pada : **Semester Genap 2022-2023**

Demikian permohonan kami, atas perkenannya disampaikan, terima kasih.



Dekan,

*[Handwritten Signature]*

**Dr. Ir. Sajjo, MKes., IPU., ASEAN Eng.**  
NPP : 20410.90.0197

## Lampiran 10 Surat Balasan Izin Penelitian



### OYITOK GROUP MALANG

CV. OYITOK COMPANY  
Sudimoro no 244 RT 4 RW 1 Kec. Bululawang  
Kab Malang-Jawa Timur  
E-mail: [oyitokoptima@gmail.com](mailto:oyitokoptima@gmail.com), Telepon: 0817 7573 2757

Nomor : HG-001/OTG/PTA/07/2023  
Lampiran : -  
Perihal : Persetujuan Penelitian Tugas Akhir

Kepada Yth.  
Dekan Fakultas Teknik  
Universitas 17 Agustus (UNTAG)  
di Tempat

Dengan hormat,  
Sehubungan dengan surat saudara dengan nomor surat : 1087/K/FT/Akd/VI/2023 tentang  
Penelitian tugas akhir maka kami, Yang bertanda tangan dibawah ini:

Nama : Muhamad Nur Kholis, S.E  
Jabatan : Owner

Menerangkan bahwa,

1. Nama Mahasiswa : M. Dzaky Arraffii  
NIM : 1411900057  
Program Studi : Teknik Industri
2. Nama Mahasiswa : Abid Nurkhourudin  
NIM : 1411900153  
Program Studi : Teknik Industri

Telah kami setuju untuk melaksanakan penelitian di Oyitok Coffee sebagai syarat untuk menyelesaikan studi pada program Strata 1.

Demikian surat ini disampaikan untuk dipergunakan sebagaimana mestinya

Hormat kami,

  
**OYITOK GROUP**  
YOUR BUSINESS PARTNER  
**Muhamad Nur Kholis**

Lampiran 11 Jurnal Bimbingan



## JURNAL BIMBINGAN TUGAS AKHIR

### PRODI TEKNIK INDUSTRI

### SEMESTER GENAP 2022/2023

---

**Nama** : ABIN NURKHORUPIN  
**NBI** : 1411 900 153  
**Judul Penelitian** :  
 REDESAIN MESIN GRINDER KOPI UNTUK MENINGKATKAN KAPASITAS  
 PRODUKSI DAN EFISIENSI KERJA PADA CV. OYITOK COMPANY  
**Dosen Pembimbing** : Hery Murnawan, S.T., M.T., CSCA





No.	Tanggal	Materi Bimbingan	Catatan Pembimbing	Paraf Pembimbing
1	3 Maret 2023	Pencarian Penelitian	Revisi Judul - Data yg digunakan - Sajikan flowchart ke - Rancangan hasil akhir	<i>[Signature]</i>
2	10 Maret 2023	Flowchart	Rushda terkait rumus perhitungan Saving	<i>[Signature]</i>
3	13 Maret 2023	BAB II	Vehicle Routing Model / CVRP	<i>[Signature]</i>
4	14 Maret 2023	Teori Saving	Penerapan rumus Saving matrix	<i>[Signature]</i>
5	15 Maret 2023	Data & Populasi	Abstrak, data, Bab II	<i>[Signature]</i>
6	16 Maret 2023	Seminor	Persepsi Seminar, flowchart penelitian	<i>[Signature]</i>
7	4 Mei 2023	BAB III	Data sekunder : S sama, PO, faktor	<i>[Signature]</i>
8	16 Mei 2023	BAB IV	Kelengkapan Data	
9	25 Mei 2023	BAB V	Mengumpulkan data	
10	27 Juli 2023	BAB I	Latar belakang	
11	15 Agustus 2023	BAB III	Metodologi Penelitian	<i>[Signature]</i>
12	6 Oktober 2023	BAB I	Latar belakang	
13	10 Nop 2023	BAB IV	Metode	<i>[Signature]</i>
14	5-12-2023	BAB V	Kesimpulan	





### Lampiran 12 Foto Bimbingan

No	Foto Bimbingan	Tanggal & Materi Bimbingan
1		<p>3 Maret 2023</p> <ul style="list-style-type: none"> <li>• Revisi Judul</li> <li>• Penggunaan Data</li> <li>• Flowchart</li> </ul>
2		<p>10 Maret 2023</p> <p>Perbaiki Pustaka Terkait</p>
3		<p>13 Maret 2023</p> <p>Vehicle Routing Problem</p>

4	 <p>14 Mar 2023 17:46:32 Surabaya East Java Indonesia 17 August 1945 University Surabaya</p>	14 Maret 2023  Penerapan dan Penggunaan Rumus Saving
5	Foto Hilang	15 Maret 2023  Abstrak, Data, Referensi
6	Foto Hilang	16 Maret 2023  Persiapan Seminar



<p>7</p>	 <p>The image shows two men sitting at a desk in an office. The man on the left is wearing a blue and white patterned batik shirt, and the man on the right is wearing a light blue jacket. They are looking at papers on the desk. A GPS overlay is visible in the bottom right corner of the photo, displaying the following information: 'GPS Map Camera', 'Kecamatan Sukolilo, Jawa Timur, Indonesia', 'X, Jl. Manyar Rejo No.37, Menur Pumpungan, Kec. Sukolilo, Kota SBY, Jawa Timur 60118, Indonesia', 'Lat -7.297888°', 'Long 112.76624°', and '04/05/23 07:05 PM GMT +07:00'. A small Google Maps inset is also present in the bottom left of the overlay.</p>	<p>4 Mei 2023</p> <p>Surat Jalan dan Fraktur</p>
<p>8</p>	 <p>The image shows two men sitting at a desk in an office. The man on the left is wearing a light blue shirt, and the man on the right is wearing a grey jacket. They are looking at papers on the desk. A water bottle is visible on the desk. A GPS overlay is visible in the bottom right corner of the photo, displaying the following information: 'GPS Map Camera', 'Kecamatan Sukolilo, Jawa Timur, Indonesia', 'X, Jl. Manyar Rejo No.37, Menur Pumpungan, Kec. Sukolilo, Surabaya, Jawa Timur 60118, Indonesia', 'Lat -7.297899°', 'Long 112.768256°', and '16/05/23 04:08 PM GMT +07:00'. A small Google Maps inset is also present in the bottom left of the overlay.</p>	<p>16 Mei 2023</p> <p>Kelengkapan data</p>

9		25 Mei 2023 Menggunakan Metode Sweep
10	Foto Hilang	27 Juli 2023 Latar Belakang

11	Foto Hilang	15 Agustus 2023 Metodologi Penelitian
12	Foto Hilang	6 Oktober 2023 Latar Belakang

<p>13</p>		<p>10 Nopember 2023</p> <p>Metode</p>
<p>14</p>		<p>5 Desember 2023</p> <p>Kesimpulan</p>

UNIVERSITAS 17 AGUSTUS 1945 SURABAYA  
 FAKULTAS TEKNIK  
 PROGRAM STUDI TEKNIK INDUSTRI

**REVISI SIDANG TUGAS AKHIR**

NAMA : Abid Nurkhoirudin  
 NBI : 1411900153  
 JUDUL : Redesain Mesin Grinder Kopi Untuk Meningkatkan Kapasitas Produksi dan Efisiensi Kerja pada CV. Oyiok Company  
 BATAS BIMBINGAN REVISI : 1 Minggu setelah Sidang

NO	URAIAN	BAB	HALAMAN
1	Tabel 4.1, 4.5 diberi unit satuan		
2	Foto-foto kegiatan masuk ke lapangan		65 - 69
3	Kagaimana memastikan bahwa hasil stae kopi mesin lama dan baru adalah sama?		70
4	Yang dibandingkan per level bukan rata-rata		70

NO	URAIAN	BAB	HALAMAN
1.	Raijeraan uraian Efisiensi, kualitas dan Kapasitas harus tuntas dan berkembang satu sama lain.		
2.	Tujuan dan kearifan pulcan urutkan berdasarkan urgenter paisevritan		
3.	Daftar pustaka etich' dation		

Telah Direvisi:  
 Dosen Penguji 1,

Herlina, ST., MT

Dosen Penguji 2,

Purno Eka Devi Karunia Wati, ST., MT, CSCA

Surabaya, 07 Desember 2023  
 Mengstahui  
 Dosen Pembimbing/Ketua Penguji,

Hery Murnawan, ST., MT, CSCA