

LAMPIRAN

1. Desain alat uji

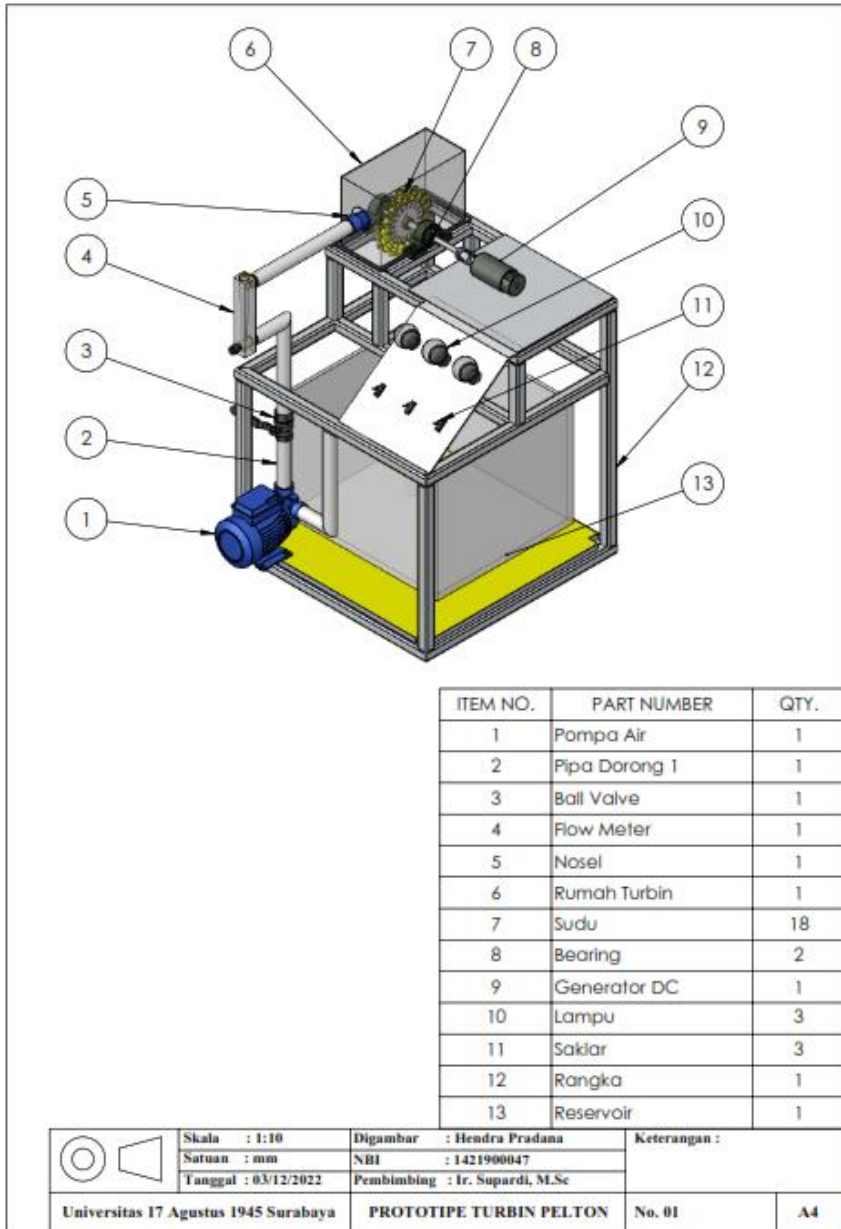

2. Desain sudu

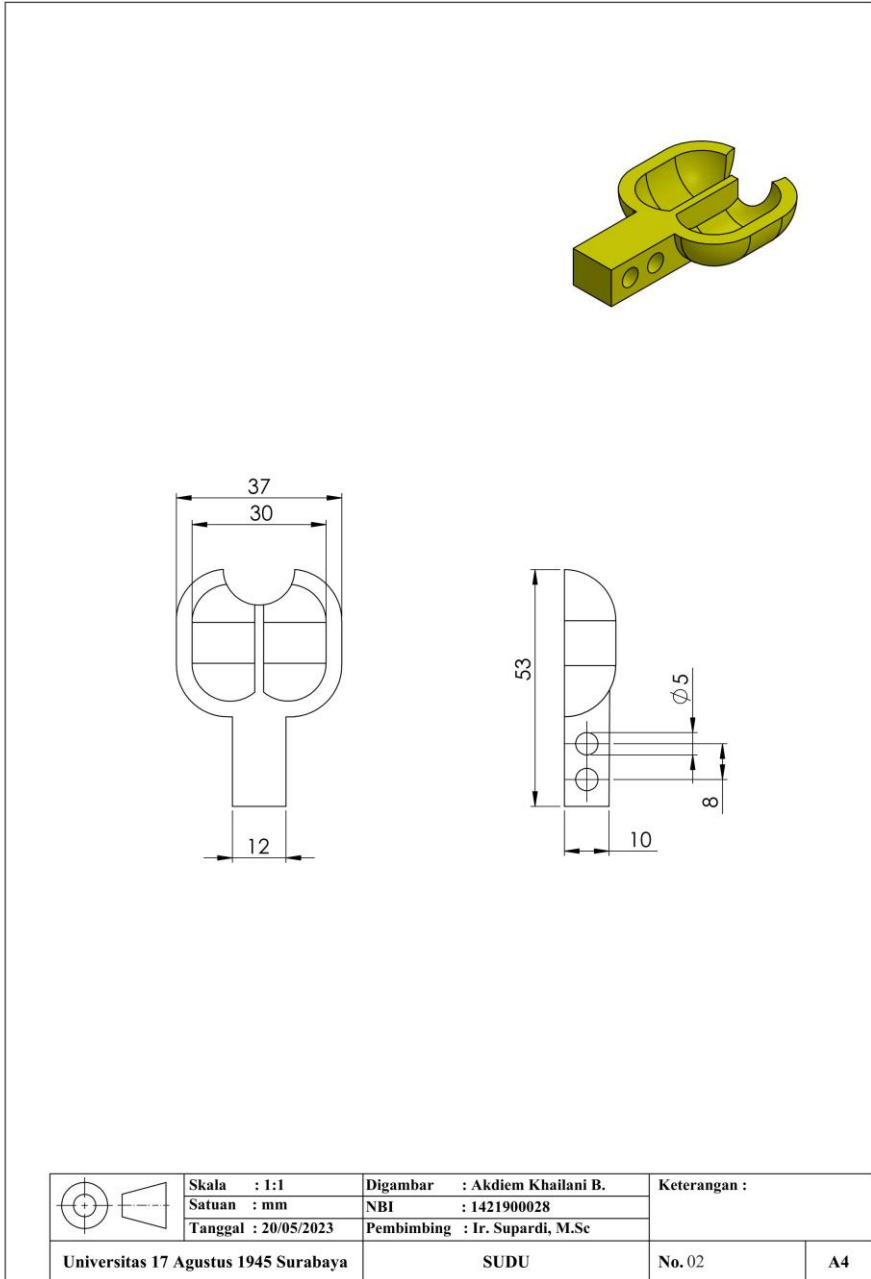

3. Desain Sudu

Variasi diameter nosel 9 mm

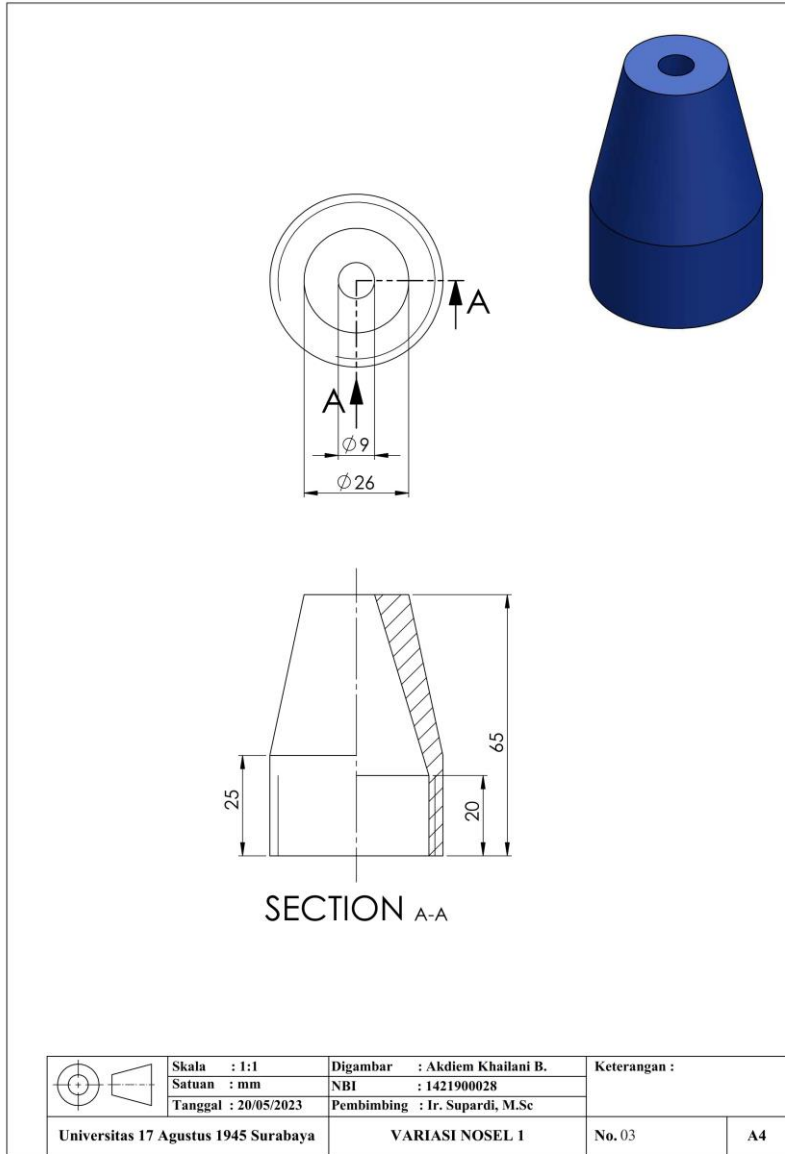

Variasi diameter nosel 10 mm

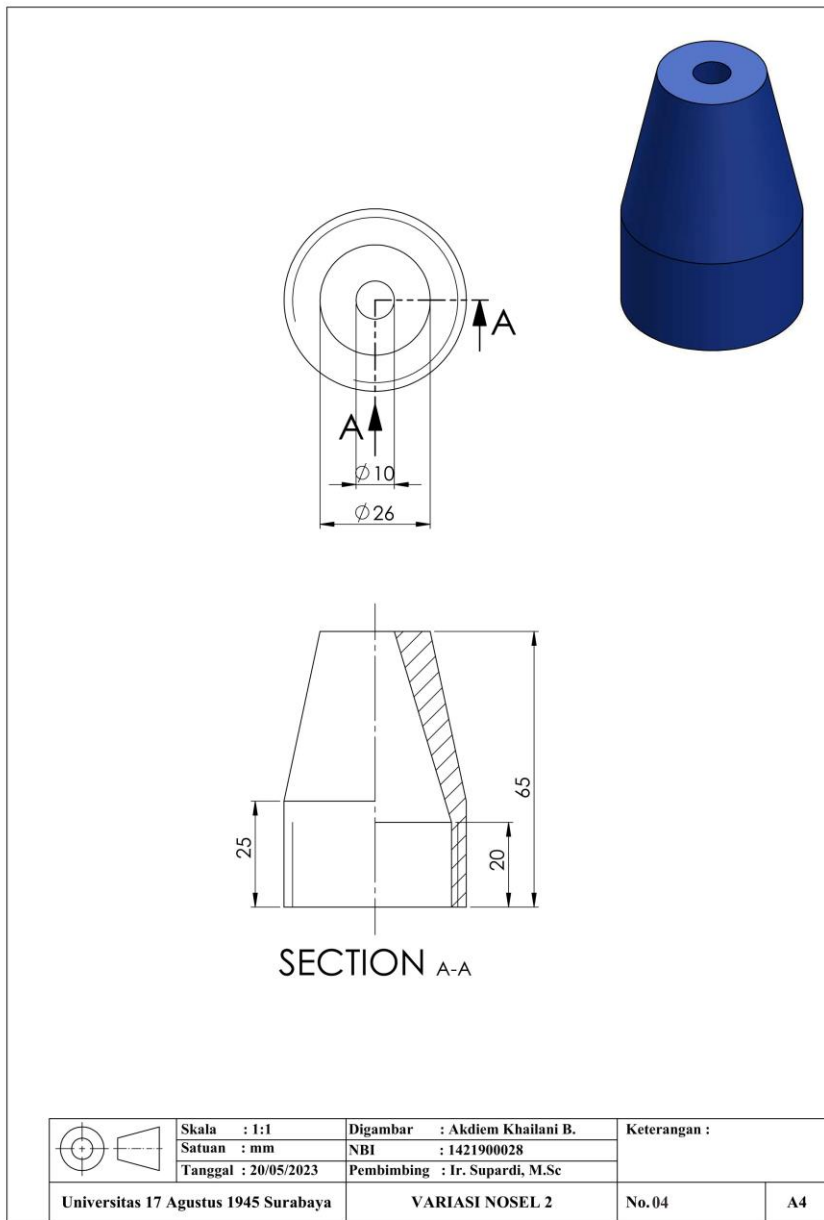

Variasi diameter 11 mm

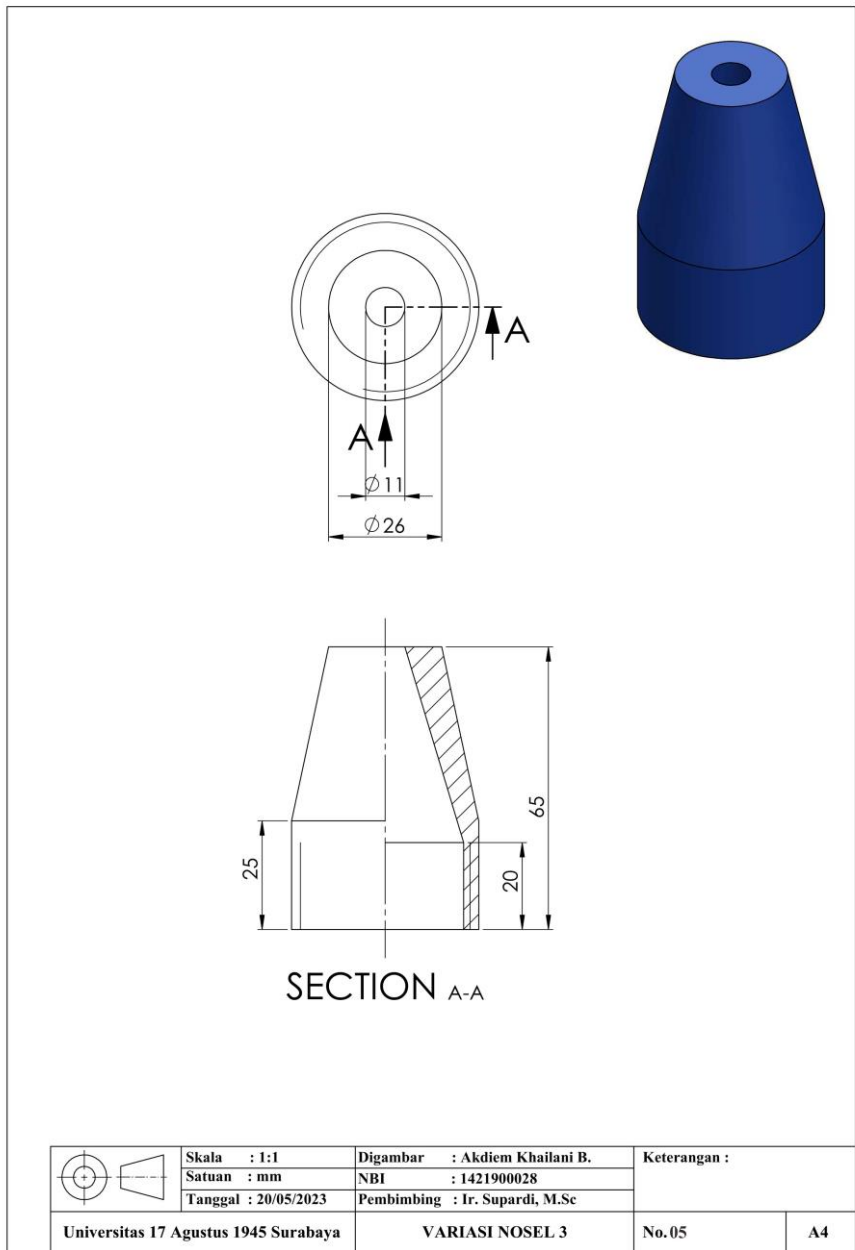

4. Desain Runner

Diameter Runner 110 mm

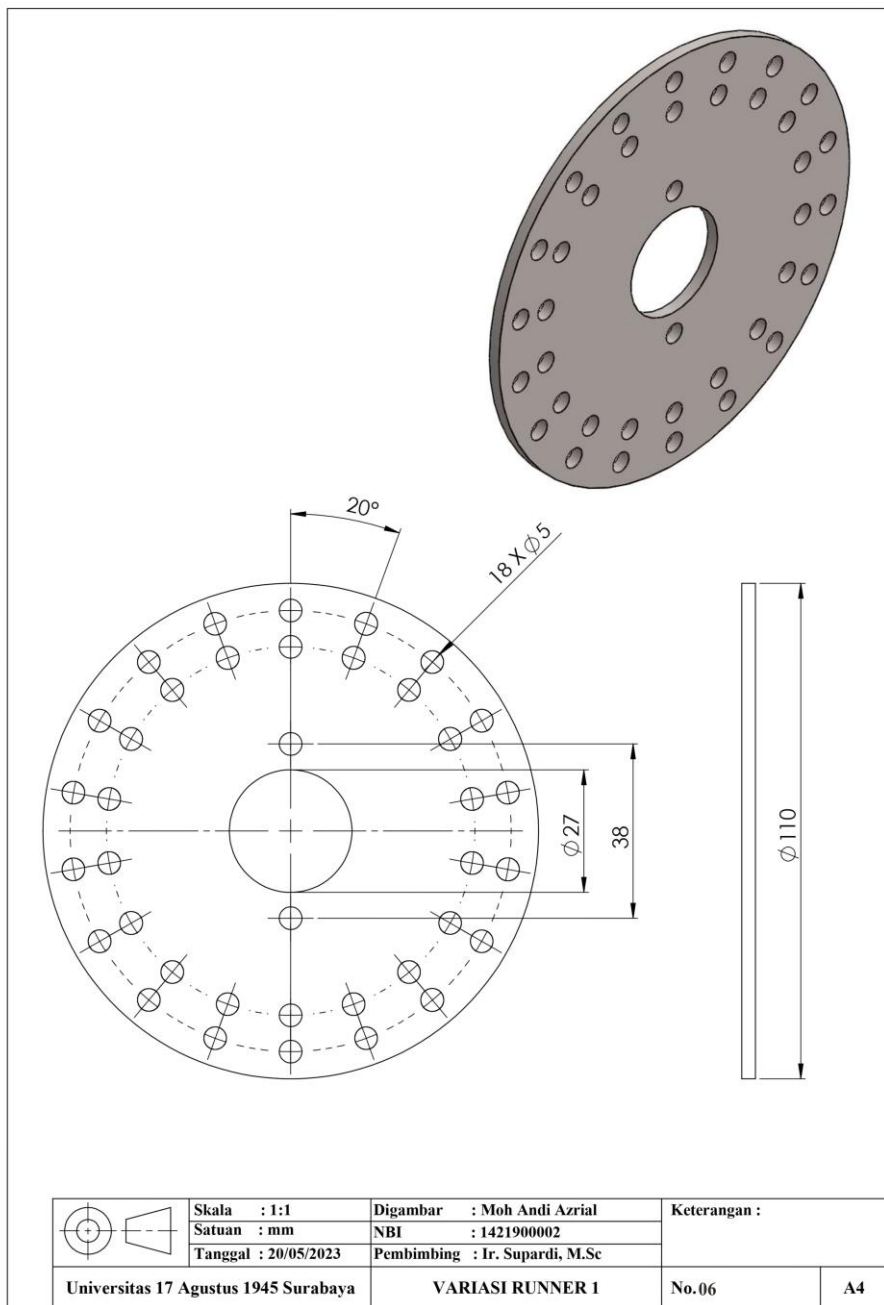

Diameter Runner 115 mm

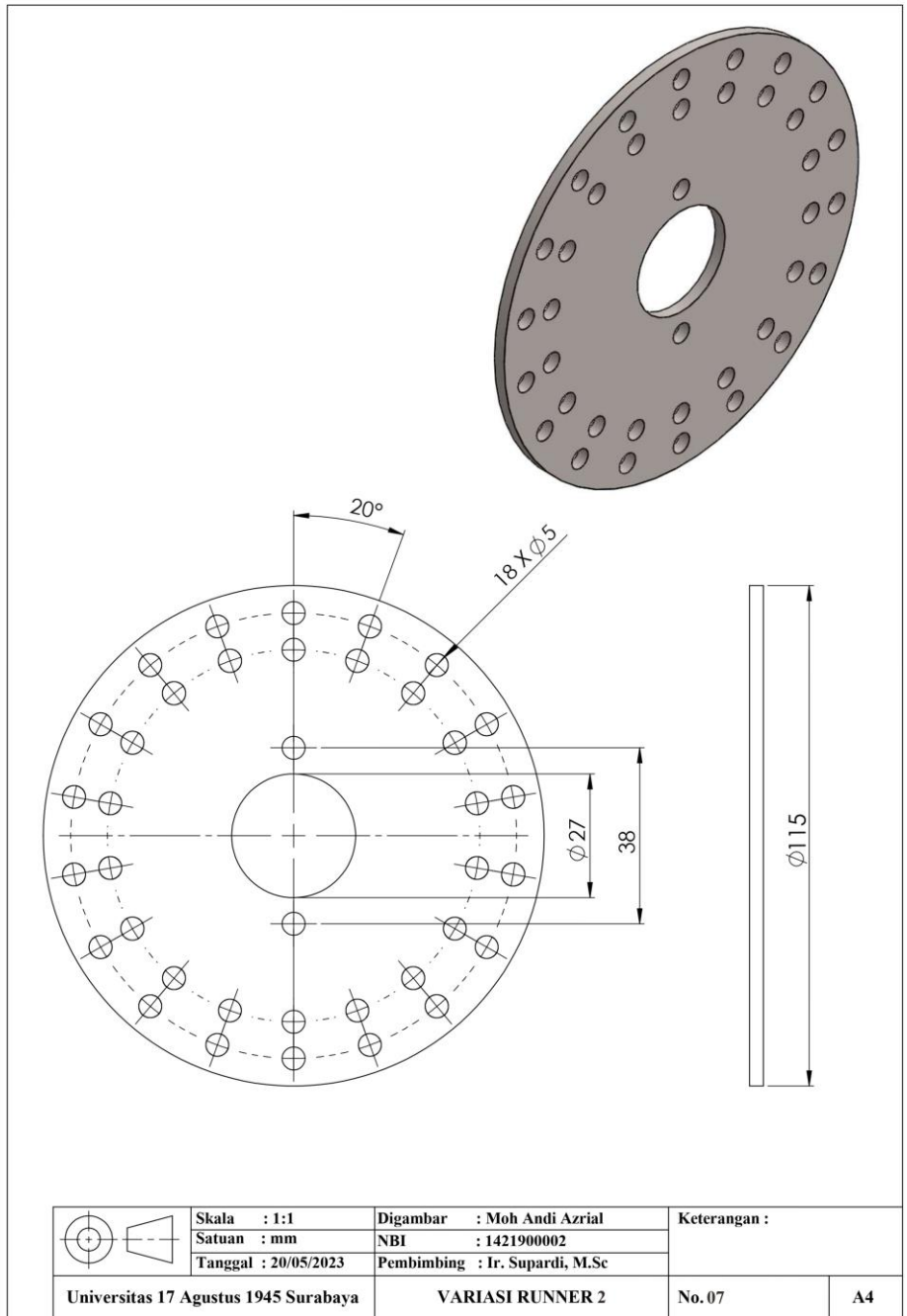

Diameter Runner 120 mm

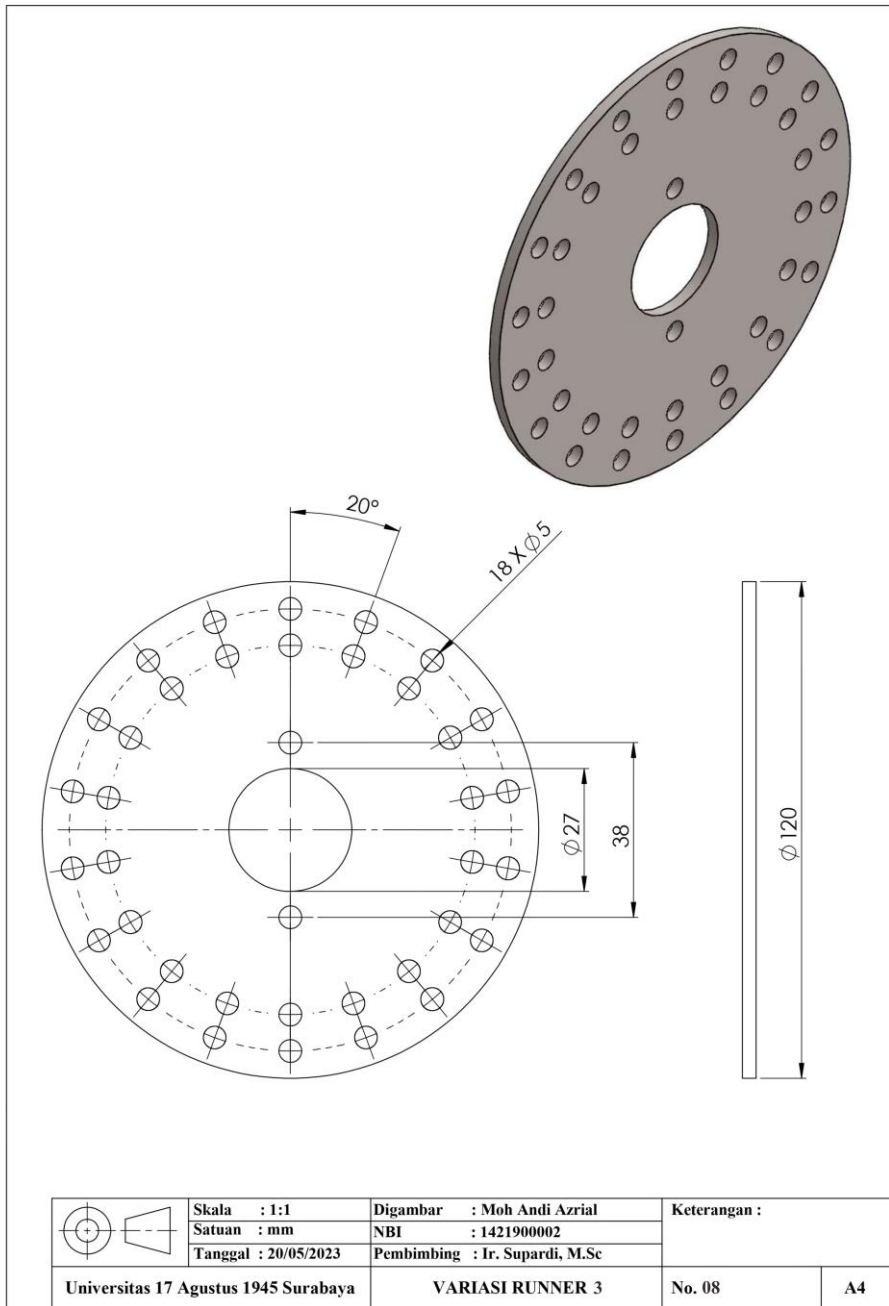

5. Proses pembuatan cetakan

Cetakan sudu hasil



Memotong akrilik untuk wadah pembuatan cetakan



Pembuatan cetakan dengan media malam dan menaruh cetakan sudu hasil 3D Print pada wadah yang terbuat dari akrilik



Membuat bahan adonan dengan mencampurkan Silicone Rubber RTV-48 dan Catalyst RTV-SB, lalu menuangkan pada wadah pembuatan cetakan dari akrilik

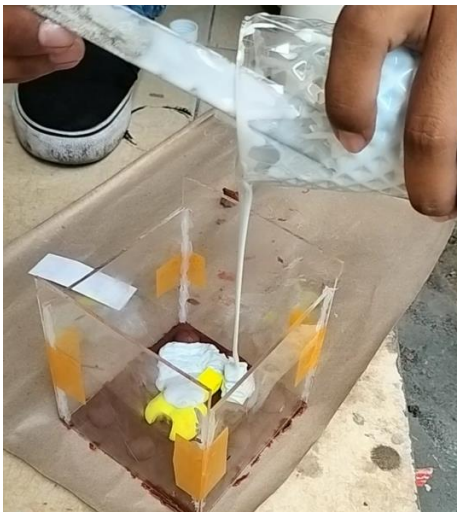

Membirakan cetakan hingga kering

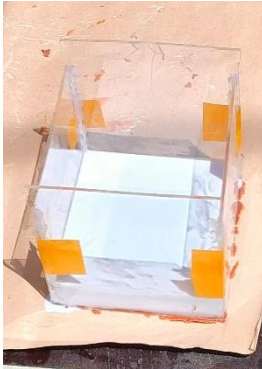

Hasil pembuatan cetakan



6. Proses pembuatan sudu

Membuat material resin dengan mencampurkan dengan katalis



Hasil pembuatan sudu dengan cetakan



7. Proses pengambilan data

Alat uji



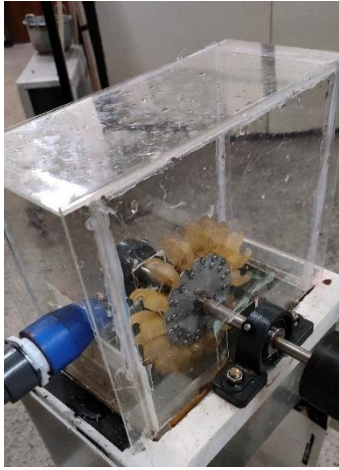

Pengambilan data



