

LAMPIRAN

1. Persiapan bahan

A

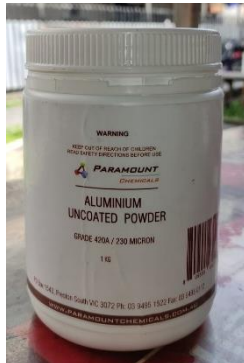

B



Keterangan : A. Aluminium (Al) B. Titanium (Ti)

2. Desain Cetakan

A

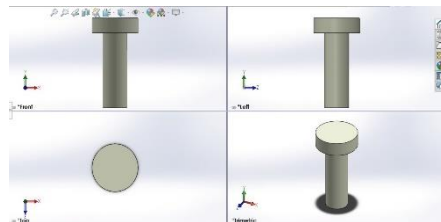

B

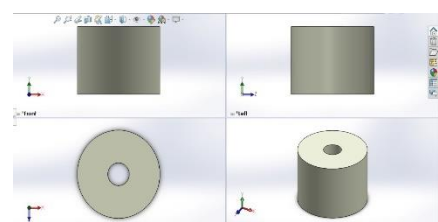

C

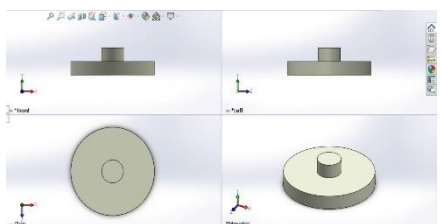

D

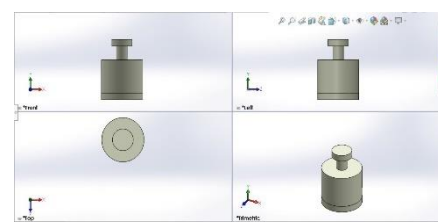

E

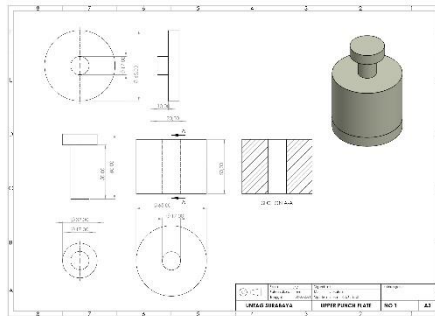

Keterangan : A. Desain Pen pendorong
B. Desain badan Cetakan Tengah
C. Desain Penutup bawah cetakan
D. Desain Cetakan
E. Gambar Teknik cetakan

3. Proses Pencampuran

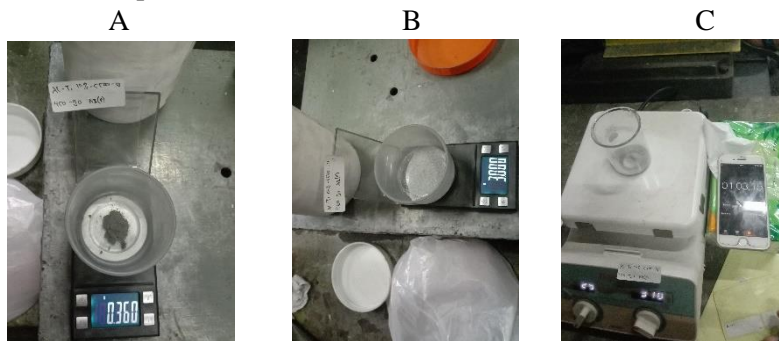

Keterangan : A. Penimbangan partikel Titanium (Ti)
B. Penambahan Partikel Aluminium (Al)
C. Proses pencampuran (*mixing*)

4. Proses Pencetakan

A



B



C



D



E



F



- Keterangan :
- A. Alat *press* hidrolik
 - B. Alat cetakan spesimen
 - C. Penuangan partikel paduan Al-Ti 12% pada cetakan
 - D. Waktu awal pengepresan menggunakan *press* hidrolik dengan tekanan 5500 Psi dalam waktu 10 menit
 - E. waktu akhir pengepresan menggunakan *press* hidrolik dengan tekanan 5500 Psi dalam waktu 10 menit
 - F. Penimbangan berat spesimen setelah pencetakan

5. Proses sintering

A



B



C



D



E



- Keterangan :
- A. Alat perlakuan panas (*furnace*)
 - B. Tata letak spesimen kedalam oven (*furnace*)
 - C. Suhu awal pada oven (*furnace*)
 - D. Sintiring dilakukan pada suhu 450°C dalam waktu 90 menit
 - E. Pendinginan spesimen dengan temperatur ruangan

6. Proses pengujian densitas

A



B



Keterangan : A. Pengukuran tinggi benda spesimen
B. Penimbangan massa benda spesimen

7. Proses Pengujian struktur mikro

A



B



C



Keterangan : A. Alat mikroskop

B. Proses pengujian struktur mikro

C. Hasil dari pemotretan struktur mikro pada spesimen

8. Proses pengujian kekerasan Rockwell (HRB)

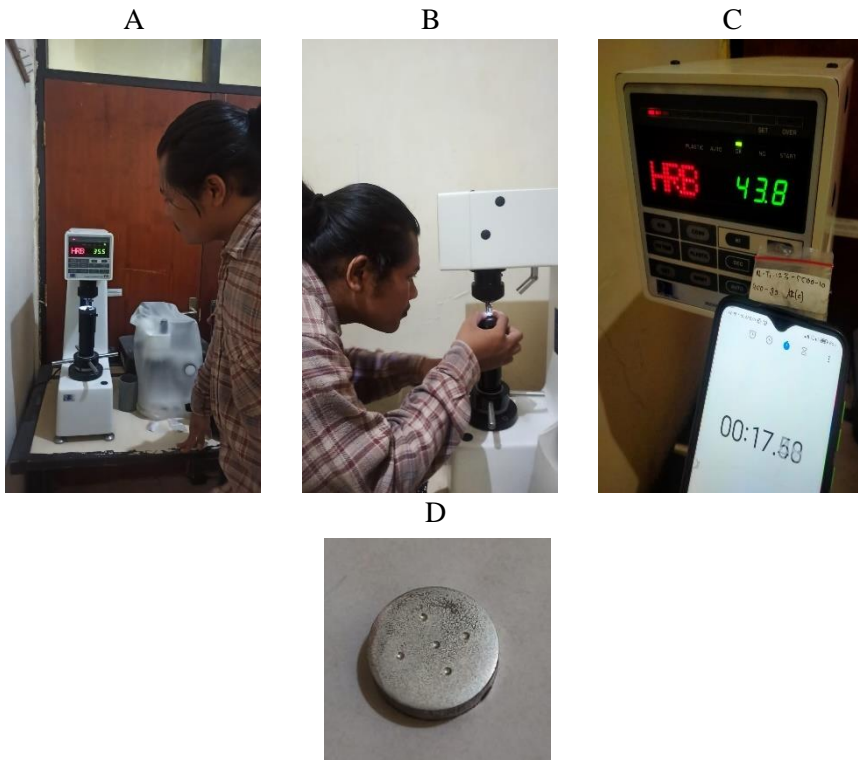

Keterangan : A. Alat kekerasan menggunakan metode HRB
B. Proses pengujian kekerasan
C. Hasil dari pengujian kekerasan HRB
D. Sampel setelah menguji kekerasan HRB

	Laboratorium Pengujian Bahan & Pelapisan Logam Jurusan Teknik Mesin – Fakultas Teknik Universitas Negeri Surabaya
	Pengujian Kekerasan HRB (Hardness Rockwell B)

SURAT KETERANGAN

Surabaya, 17 Mei 2022

Yth. Ketua Program Studi Teknik Mesin
 Universitas 17 Agustus 1945 Surabaya
 Di tempat

Dengan hormat,

Yang bersangkutan di bawah ini:

NO	NAMA	NBI
1	Muhammad Amirul Mahfud	1421800175

Telah melakukan Pengujian Kekerasan Rockwell B (HRB) di Laboratorium Pengujian Bahan Jurusan Teknik Mesin Universitas Negeri Surabaya.

Demikian surat keterangan ini. Atas perhatiannya, kami ucapkan terima kasih.

Surabaya, 17 Mei 2022

KaSubLab.

Pengujian Bahan & Pelapisan Logam



 (Tri Hartutuk Ningsih, S.T.,M.T.)

	Laboratorium Pengujian Bahan & Pelapisan Logam Jurusan Teknik Mesin - Fakultas Teknik Universitas Negeri Surabaya
	Pengujian Kekerasan HRB (Hardness Rockwell B)

TABEL PENGUJIAN KEKERASAN (HRB)

1. Table hasil uji kekerasan Al-Ti 12%

Pengujian kekerasan								
No	Kompaksi	Suhu	sampel	Titik nilai uji kekerasan				
1	5000	450	a	42.5	43.8	43.6	43.9	45.9
2			b	43.5	43.7	44.1	44.8	45.4
3			c	45.3	46.3	48.6	46.4	48.6
4			d	45.2	47.4	44.7	46.4	45.0
5			e	45.2	43.0	45.7	45.3	43.6
6	5500		a	43.9	45.5	43.7	43.2	46.1
7			b	46.1	43.9	44.9	47.1	47
8			c	43.8	43.2	44.2	44.9	43.1
9			d	45	44.8	43.8	45.6	44.4
10			e	43.8	43.5	44.1	44.2	46.3
11	6000		a	47.4	49.9	46.8	44.8	45.6
12			b	44.7	43.8	43.8	44.9	44.8
13			c	45.8	45.4	44.8	46.5	44.6
14			d	44.8	45.1	41.7	47.3	43.6
15			e	47	47.2	43.4	43.3	43.2
16	6500		a	45.3	43.7	43.8	43.6	44.1
17			b	45.7	44	47.4	48.5	44.9
18			c	44.5	42.7	46.4	42.3	43.3
19			d	47	45.4	42.2	44.8	42.5
20			e	43.5	41.4	42.4	41.3	42.8
21	7000		a	45.7	44.5	43.6	46.9	42.4
22			b	45.5	41.7	44.3	43.5	44.4
23			c	42.6	43.9	42.7	43	42.8
24			d	43.8	42.9	41.6	43	45
25			e	46.3	43.5	45.4	48.3	43.6

	Laboratorium Pengujian Bahan & Pelapisan Logam Jurusan Teknik Mesin – Fakultas Teknik Universitas Negeri Surabaya
	Pengujian Kekerasan HRB (Hardness Rockwell B)

26	5000	500	a	44.6	43.1	42.9	42.8	46.3
27			b	43.1	45	43.8	43	45.6
28			c	42.8	42.4	44.4	44.7	42.3
29			d	47.1	44.8	46	42.1	44.5
30			e	45.5	45.7	43.2	42.7	44.5
31	5500		a	43.9	42.1	41.4	42.3	44.1
32			b	43.2	41.7	42.1	44.4	44.4
33			c	44.1	41.9	43.8	42.6	42.1
34			d	48	44.3	43.5	42.7	44.4
35			e	48	44.2	42.6	45.6	43.7
36	6000		a	45.4	42.3	46.7	43	44.6
37			b	42.6	42.7	39.7	42.6	42.3
38			c	46.2	43	46.4	44.7	43.8
39			d	44.3	45	42.7	44.2	43.9
40			e	46.7	45.4	43.2	44	44.9
41	6500		a	44.5	43.2	43.4	42.9	43.9
42			b	45.6	43.1	47.4	47.6	48
43			c	42.5	41.4	41.8	41.1	44.1
44			d	44.3	43.5	42.7	43.6	46.6
45			e	43.1	42.4	43	41.8	44.1
46	7000		a	44.7	45.1	46	45.2	41.7
47			b	44	43.9	43.1	43.6	43.1
48			c	45.9	46.3	46	46.2	45
49			d	45	45.7	43.4	43.2	44.4
50			e	42.7	41.8	40.9	42.5	41.2



SURAT KETERANGAN
NOMOR : 11/LAB.TM/2022

Yang bertanda tangan dibawah ini :

Nama : Rafik Djoenaidi,ST
NIP : 19780125 200112 1 002
Jabatan : Pranata Laboratorium Pendidikan
Politeknik Negeri Malang

Menerangkan dengan sesungguhnya bahwa mahasiswa :

Nama : M. Amirul Mahfud
Nim : 1421800175
Program Studi : S-1Teknik Mesin
Fakultas : Teknik Universitas 17 Agustus 1945 Surabaya

















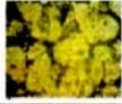

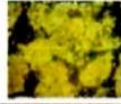





Benar benar telah melaksanakan pengambilan data di Jurusan Teknik Mesin Politeknik Negeri Malang , guna keperluan penyusunan skripsi.

Demikian surat keterangan ini dibuat untuk dipergunakan sebagaimana mestinya.

Malang, 23 Mei 2022
Pranata Laboratorium Pendidikan
Politeknik Negeri Malang

















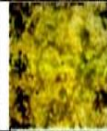

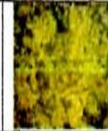

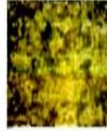





Rafik Djoenaidi,ST
19780125 200112 1 002

Paduan Al-Ti 12% Suhu Sintering 450°C					
Kompaksi (Psi)	Spesimen				
	a	b	c	d	e
5000					
5500					
6000					
6500					
7000					











gr

PENGUJIAN & PERLAKUAN
BAHAN
 LAB. BAHAN TEKNIK MESIN
 POLITEKNIK NEGERI MALANG









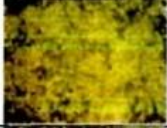

Paduan Al-Ti 12% Suhu Sintering 500°C					
Kompaksi (Psi)	Spesimen				
	a	b	c	d	e
5000					
5500					
6000					
6500					
7000					

gk

PENGUJIAN & PENELITIAN
BIM
 LAB. BAHAN TEKNIK MESIN
 POLITEKNIK NEGERI MALANG

Aluminium murni suhu sintering 450°C		
Kompaksi (Psi)	Spesimen	
	a	b
5000		
5500		
6000		
6500		
7000		



Aluminium murni suhu sintering 500°C		
Kompaksi (Psi)	Spesimen	
	a	b
5000		
5500		
6000		
6500		
7000		

gk

**PENGUJIAN & PERLAKUAN
BAHAN**

LAB. BAHAN TEKNIK MESIN
POLITEKNIK NEGERI MALANG

Tabel hasil pengujian densitas paduan Al-Ti12% temperatur sintering 450°C

Pengujian densitas Al-Ti 12% Temperatur 450°C								
No	Kompaksi (Psi)	Spesimen	Temperatur (°C)	Jari-jari (r)	Tinggi (t)	Massa (gr)	Densitas (gr/cm ³)	Rata-rata (gr/cm ³)
1	5000	1	450°C	8,5	4,55	2,996	2,902	2,920
2		2		8,5	4,35	2,999	3,039	
3		3		8,5	4,60	3,000	2,875	
4		4		8,5	4,45	2,959	2,931	
5		5		8,5	4,60	2,977	2,853	
6	5500	1		8,5	4,30	2,969	3,044	2,963
7		2		8,5	4,50	2,998	2,937	
8		3		8,5	4,40	2,951	2,956	
9		4		8,5	4,60	3,001	2,876	
10		5		8,5	4,40	2,998	3,003	
11	6000	1		8,5	4,45	2,948	2,920	2,988
12		2		8,5	4,30	2,959	3,033	
13		3		8,5	4,45	2,999	2,971	
14		4		8,5	4,45	2,968	2,940	
15		5		8,5	4,30	2,999	3,074	
16	6500	1		8,5	4,45	2,952	2,924	2,955
17		2		8,5	4,30	2,888	2,960	
18		3		8,5	4,40	2,998	3,003	
19		4		8,5	4,30	2,940	3,014	
20		5		8,5	4,60	2,999	2,874	
21	7000	1		8,5	4,45	2,954	2,926	2,950
22		2		8,5	4,35	2,919	2,958	
23		3		8,5	4,55	3,000	2,906	
24		4		8,5	4,30	2,948	3,022	
25		5		8,5	4,50	2,997	2,936	

Tabel hasil pengujian densitas paduan Al-Ti12% temperatur sintering 500°C

Pengujian densitas Al-Ti 12% Temperatur 500°C								
No	Kompaksi (Psi)	Spesimen	Temperatur °C	Jari-jari (r)	Tinggi (t)	Massa(gr)	Densitas (gr/cm ³)	Rata-rata (gr/cm ³)
1	5000	1	500°C	8,5	4,25	2,934	3,043	3,010
2		2		8,5	4,45	2,961	2,933	
3		3		8,5	4,30	2,943	3,017	
4		4		8,5	4,40	2,997	3,002	
5		5		8,5	4,25	2,943	3,052	
6	5500	1		8,5	4,60	3,001	2,876	2,918
7		2		8,5	4,45	2,959	2,931	
8		3		8,5	4,60	3,000	2,875	
9		4		8,5	4,30	2,960	3,034	
10		5		8,5	4,60	2,999	2,874	
11	6000	1		8,5	4,35	2,924	2,963	2,940
12		2		8,5	4,55	2,964	2,871	
13		3		8,5	4,45	2,958	2,930	
14		4		8,5	4,40	2,962	2,967	
15		5		8,5	4,40	2,964	2,969	
16	6500	1		8,5	4,40	2,924	2,929	2,945
17		2		8,5	4,60	2,971	2,847	
18		3		8,5	4,40	2,949	2,954	
19		4		8,5	4,40	2,998	3,003	
20		5		8,5	4,30	2,920	2,993	
21	7000	1		8,5	4,40	2,937	2,942	2,879
22		2		8,5	4,60	2,953	2,830	
23		3		8,5	4,55	2,994	2,901	
24		4		8,5	4,60	2,972	2,848	
25		5		8,5	4,50	2,935	2,875	

Tabel hasil pengujian densitas pada Al murni temperatur sintering 450°C dan 500°C

Pengujian Densitas Al murni								
Tekanan (Psi)	Spesimen	Temperatur (°C)	massa (gr)	Jari-jari (r)	Tinggi (t)	Densitas (gr/cm ³)	Rata-rata (gr/cm ³)	
5000	1	450°C	3,000	8,5	4,75	2.785	2.714	
	2		2.998	8,5	5,00	2.643		
5500	1		2.965	8,5	4,85	2.695	2.665	
	2		3,000	8,5	4,95	2.635		
6000	1		2.961	8,5	4,70	2.777	2.733	
	2		2.957	8,5	4,85	2.688		
6500	1		2.914	8,5	4,65	2.764	2.716	
	2		2.965	8,5	4,90	2.668		
7000	1		2.962	8,5	4,75	2.750	2.789	
	2		2.885	8,5	4,50	2.828		
5000	1		500°C	2.934	8,5	5,00	2.642	2.692
	2			2.923	8,5	4,70	2.742	
5500	1	2.997		8,5	4,70	2.811	2.822	
	2	2.923		8,5	4,55	2.832		
6000	1	2.914		8,5	4,85	2.649	2.695	
	2	2.889		8,5	4,65	2.740		
6500	1	2.888		8,5	4,55	2.798	2.764	
	2	2.941		8,5	4,75	2.730		
7000	1	2.935		8,5	4,55	2.843	2.793	
	2	2.955		8,5	4,75	2.743		