

## MG996R All Metal Gear Servo Motor



### ***MG996R All Metal Gear Servo Motor.***

This High-Torque MG996R Digital Servo features metal gearing resulting in extra high 10kg stalling torque in a tiny package. It features upgraded shock-proofing and a redesigned PCB and IC control system that make it much more accurate than its predecessor MG995. The gearing and motor have also been upgraded to improve dead bandwidth and centering. This high-torque standard servo can rotate approximately 120° (60° in each direction). The MG996R Metal Gear Servo also comes with a selection of arms and hardware to get you set up nice and fast servo control projects!

Pack of 1-piece/lot.

### **General Specification:**

- Model : MG996R Tower Pro.
- Weight: 55g.
- Dimension: 40.7 x 19.7 x 42.9 mm approx.
- Stall torque: 9.4 kgf·cm (4.8V ), 11 kgf·cm (6 V)
- Operating speed: 0.17 s/60° (4.8 V), 0.14 s/60° (6 V)
- Operating voltage: 4.8V a 7.2V
- Running Current: 500mA.
- Stall Current: 2.5A (6V).
- Dead band width: 5μs
- Stable and shock proof double ball bearing design.
- Temperature range: 0°C ~ 55°C.

**Detail Specification:**

**Unit: mm**

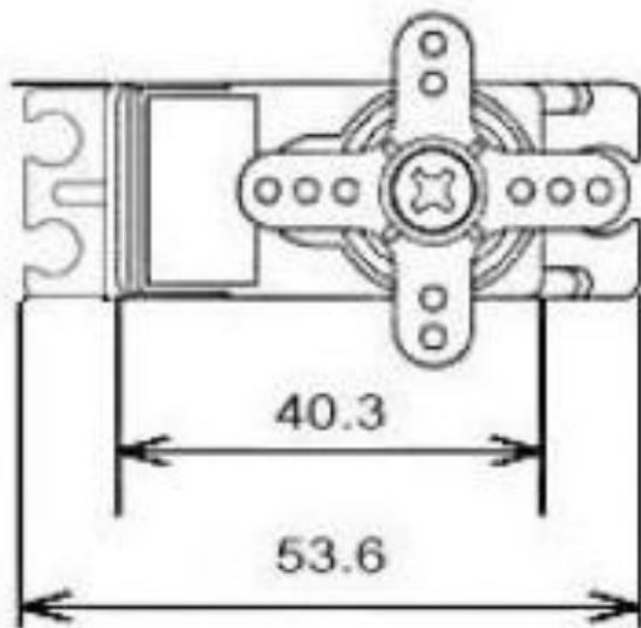
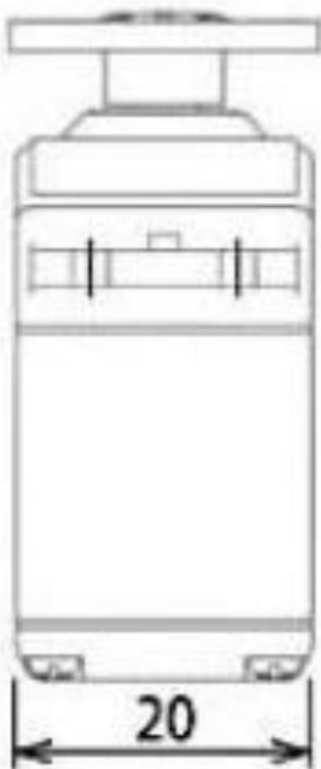
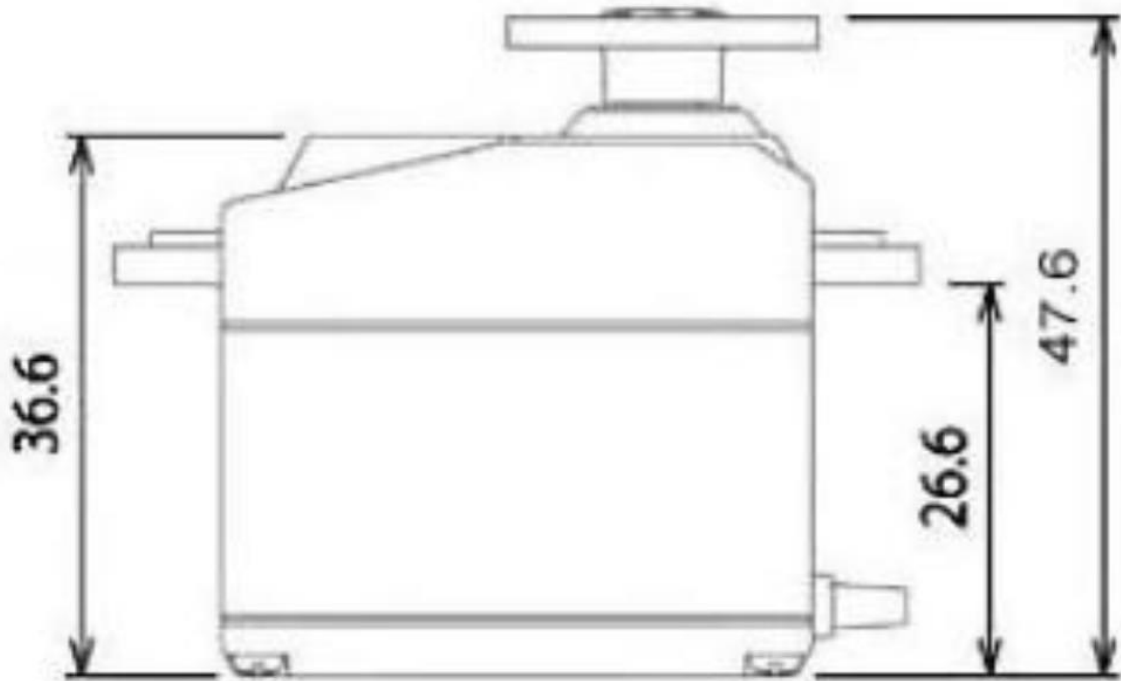

**Electrical Control Signal:**

PWM = Orange (  )  
 Vcc = Red ( + )  
 Ground = Brown ( - )

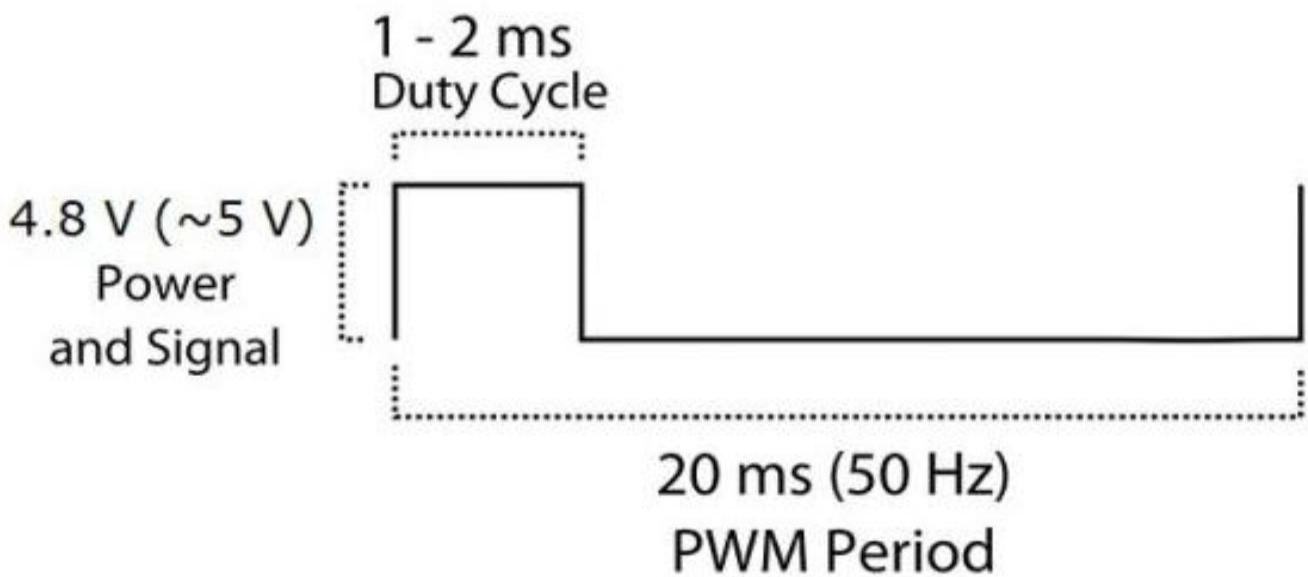
Position "0" (1.5ms pulse) is middle, "90" (~2ms pulse) is middle, is all the way to the right, "-90" (~1ms pulse) is all the way to the left.

**CONNECTOR PINOUT:**

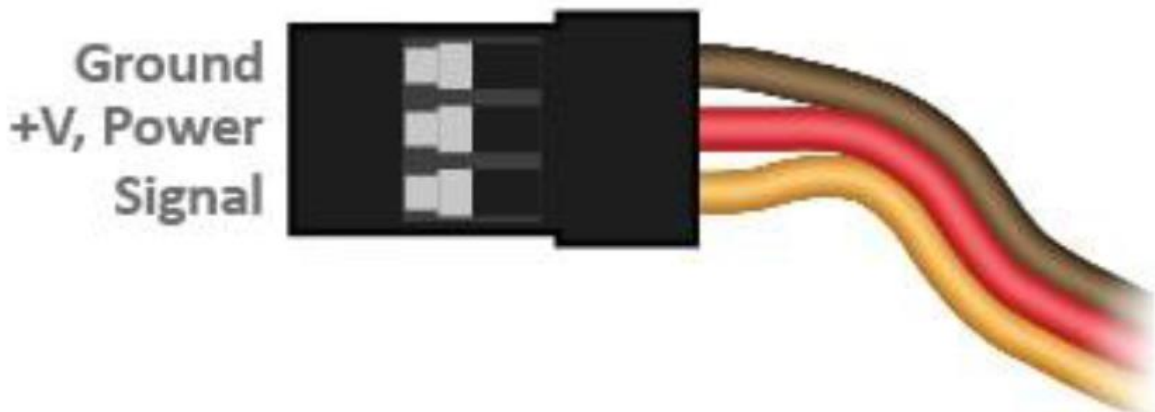

**Application With Arduino:**

**Circuit:**

Servo motors have three wires: power, ground, and signal. The power wire is typically red, and should be connected to the 5V pin on the Arduino board. The ground wire is typically black or brown and should be connected to a ground pin on the board. The signal pin is typically yellow, orange or white and should be connected to pin 9 on the board.

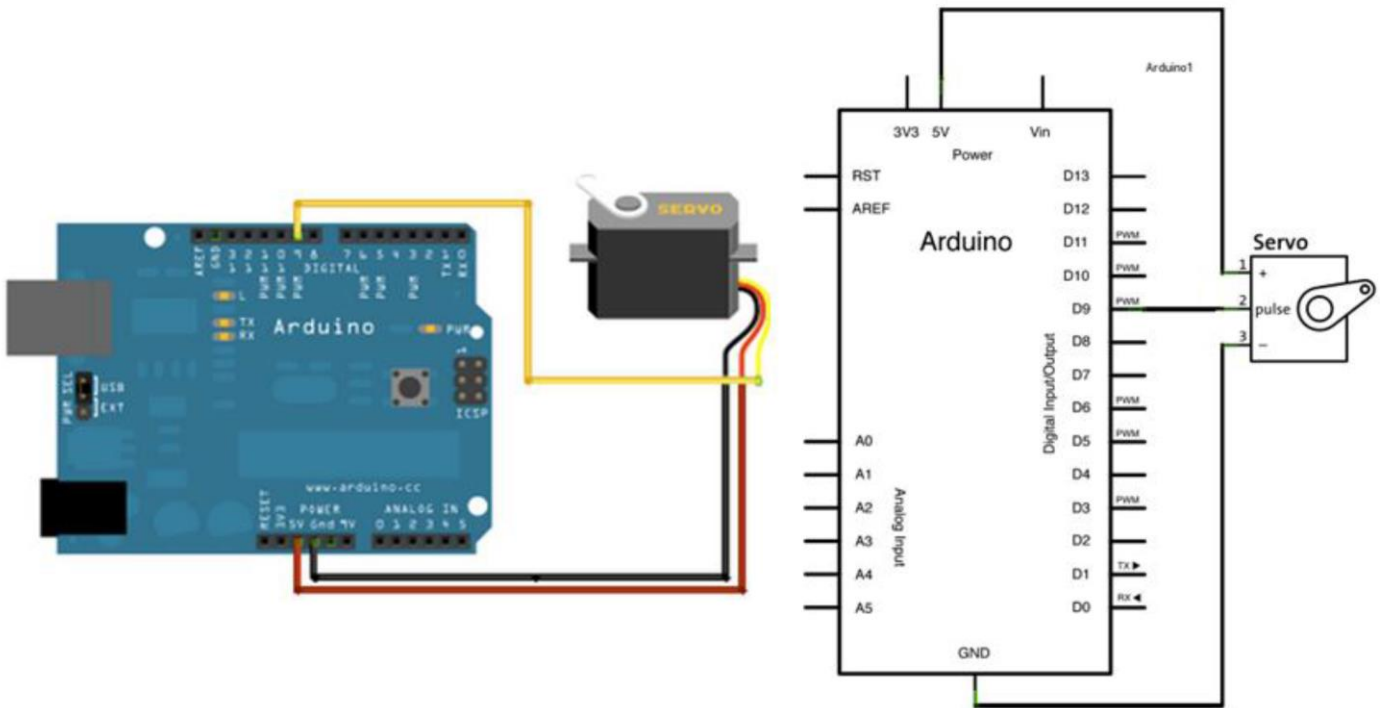

Open Arduino IDE, go to “File” > “Examples” > “Servo” > “Sweep”. Open the “Sweep” sketch and upload to your Arduino board. Attach an arm to the servo motor, you should see the arm sweeping at 180° to and fro.



